

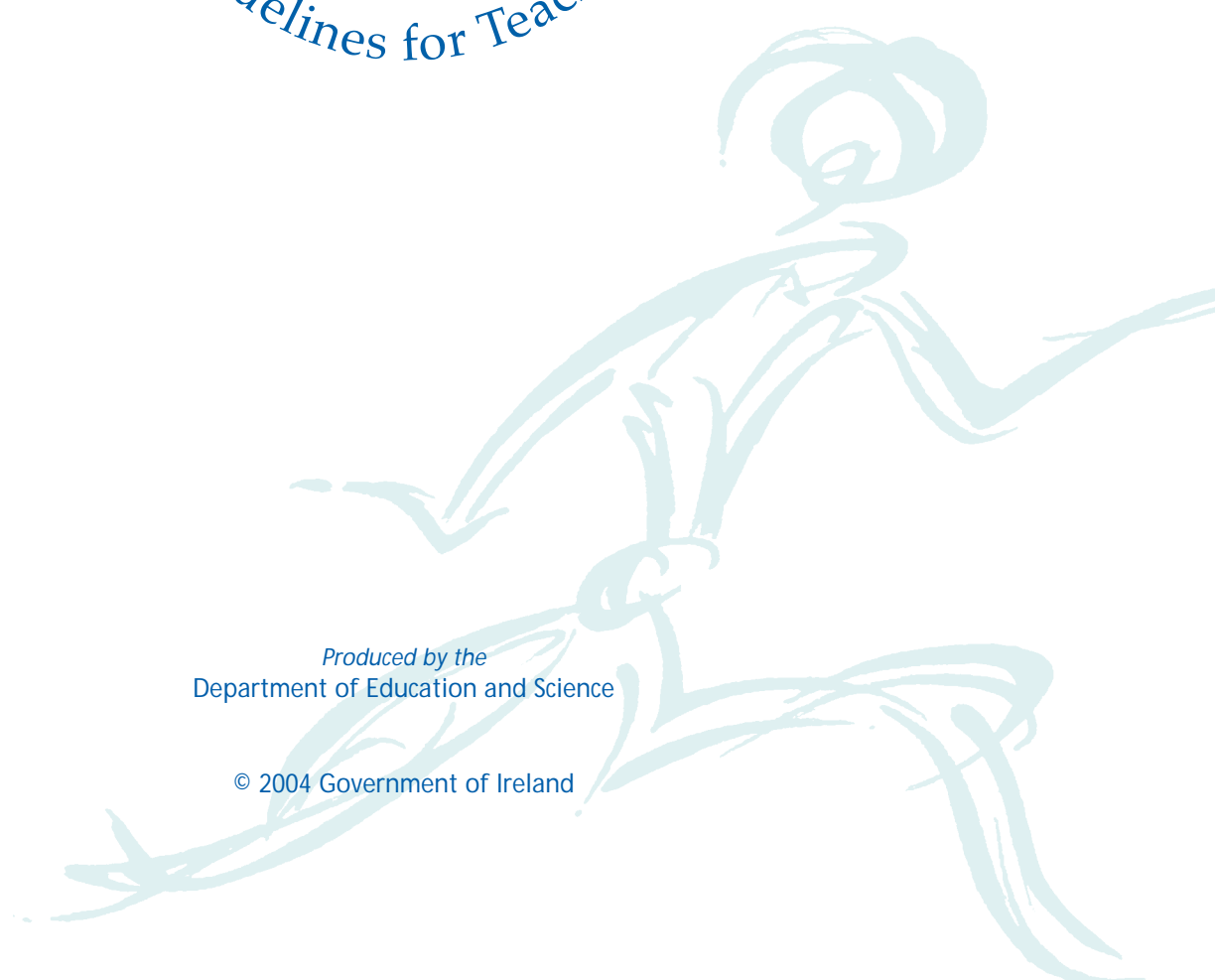

Junior Cycle Physical Education  
Guidelines for Teachers

Produced by the  
Department of Education and Science

© 2004 Government of Ireland



Introduction	1
.....	
Table of Contents	5
.....	
Adventure Activities	7
.....	
Aquatics	85
.....	
Athletics	135
.....	
Dance	179
.....	
Games	205
.....	
Gymnastics	261
.....	
Health Related Activities	309
.....	
Resources	335

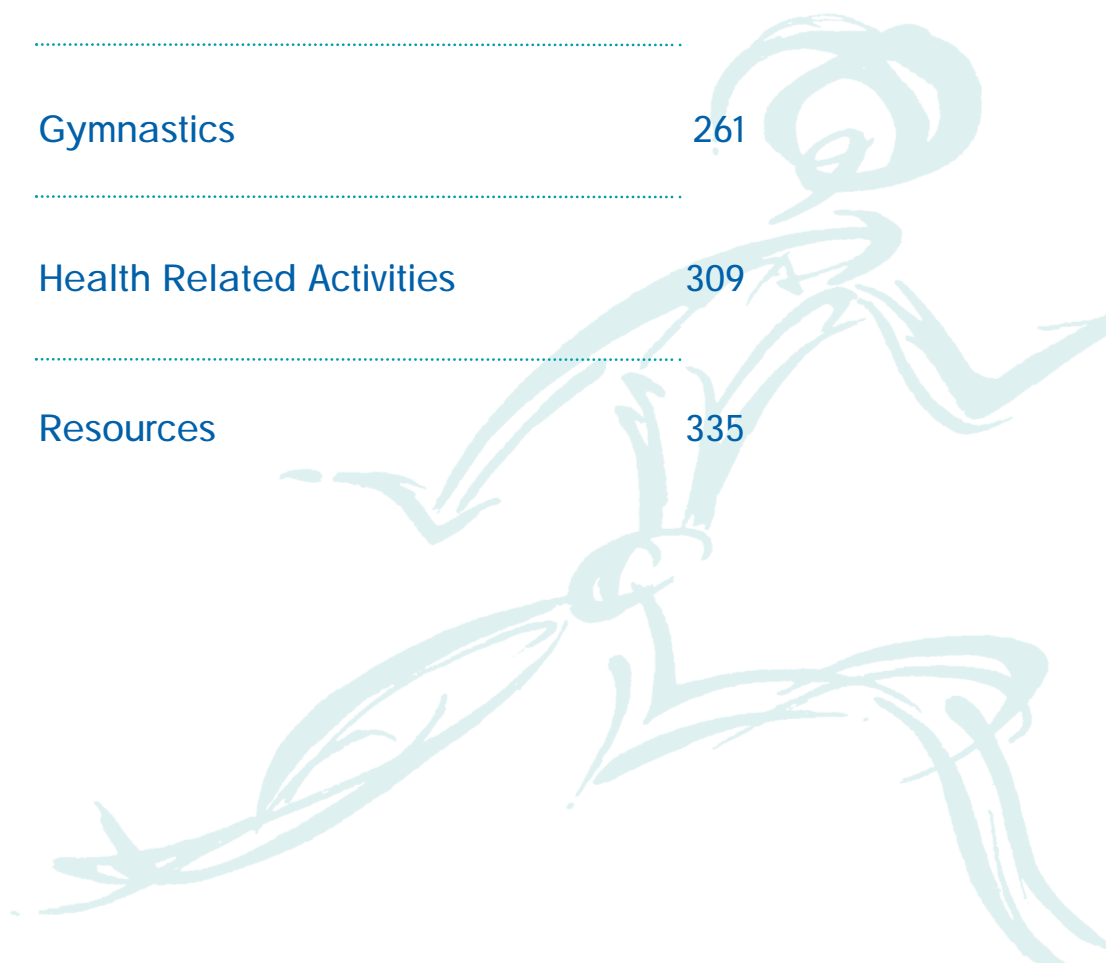

# Introduction

These teacher guidelines and the materials included with them have been developed as an aid to teachers in the implementation of the revised Junior Cycle Physical Education syllabus. Though detailed in nature, they are not intended to be prescriptive. Particular attention is given to aspects of methodology with which teachers may not be familiar. In many cases, guidance is also provided on issues of content.

## TEACHER GUIDELINES– RELATIONSHIP WITH SYLLABUS

In developing a physical education programme in school, the primary source of guidance for the teacher should be the syllabus. In the planning of such a programme the teacher should apply the curricular framework offered in the syllabus. The role of the guidelines emerges once this planning has taken place.

The aims, objectives and learning outcomes in the syllabus are presented within the teacher guidelines in a teaching context. This context is not definitive but is descriptive of school settings with which many teachers will identify. Accordingly it is envisaged that schools will be in a position to make decisions on the nature of their physical education provision which reflect individual circumstances and ethos.

## USE OF TEACHER GUIDELINES

The guidelines may be utilised in a number of ways by the teacher in the delivery of her/his programme. The units of work within the materials are organised in terms of options, which the teacher may select and/or adapt in the context of the school's physical education programme. The purpose of the units is to give teachers ideas on how elements of the syllabus might be interpreted and taught.

Every effort has been made in the design of the guidelines to ensure their applicability to the widest possible range of school settings. However, in selecting appropriate structure, content, methodologies and assessment methods for her/his programme the teacher will take a number of factors into account such as:

- *previous experience of students*
- *general ability of students*
- *facilities/teaching resources available*
- *time allocation*

## ASSESSMENT

The quality of student learning is influenced in many ways. One of these influences is assessment which can be a highly effective mechanism for promoting student learning and performance. The assessment envisaged by the syllabus and by the teacher guidelines is formative in nature. Whether formal or informal, it is primarily intended to help a student attain a higher level of performance and understanding. Through a properly structured assessment scheme feedback can be regularly provided to the student in order to assist his/her learning and to the teacher so as to facilitate informed planning. This is an essential element of the teaching / learning process.

The syllabus provides a substantial degree of flexibility to the teacher in relation to the choice of methods of assessment to be employed. Critical decisions as to the frequency of assessments and nature of feedback provided are at the discretion of the teacher.

It is recognised that the physical education teacher frequently has special demands placed on her/him as a result of the structure of the school timetable and the large numbers of students taught each week. These and other challenges may influence the implementation of a coherent assessment scheme. However, with a flexible approach, using some of the innovative modes of assessment included in these guidelines, it should be possible to deal effectively with these obstacles.

## STRUCTURE OF TEACHER GUIDELINES

*The materials are presented at two levels.*

**Level One** incorporates content and methodologies appropriate to the students' first experience of the particular physical education activity at post-primary school. It is introductory in nature and is accessible to students with a variety of physical education backgrounds. This level presupposes experience of the activity in primary school but such experience is not viewed as a pre-requisite.

**Level Two** builds upon learning attained at the preceding level and caters for students whose abilities and aptitudes are more advanced. The selection of content and suggested teaching approaches are designed to deepen the students' understanding of the activity and enhance their performance level.

## FORMAT OF LEVELS

All activities have a similar structure within the guidelines. This comprises:

### 1. Introduction

This presents a brief statement on the rationale for the inclusion of the activity. It also describes briefly the particular structural aspects of the activity.

### 2. Overall Aims and Objectives

These are derived from the syllabus and are the basis for decisions made in relation to content selection and suggested methodology.

### 3. Learning Outcomes

The learning outcomes are taken directly from the syllabus and identify, in a detailed manner, the learning that is envisaged as a result of the students' participation in the activity

### 4. Content Framework

The content for the various units within each level is clearly laid out in a framework graphic. It is hoped that this will give an overview of the scope of the work to be undertaken by the students.

### 5. Units

Each level comprises six units of work. These are set out in a detailed way so as to present the teacher with a significant amount of guidance methodological approaches.

Each unit contains:

- *learning outcomes*
- *required resources*
- *class organisation notes*
- *detail of suggested content*
- *relevant teaching points*
- *specific resource material*

### 6. Resource Material

Some additional material is made available in the guidelines to provide further support for teachers.

### 7. Assessment

Where there are assessment instruments specifically related to particular levels, these will be included within that level.

### 8. Recommended Resources

A list of relevant resources is provided to offer further guidance to teachers.

*These guidelines were devised by practising teachers and were subsequently tested in a large number of schools throughout the country. The teaching and learning experiences of the teachers and students in those schools contributed to the refinement of the guidelines.*



# CONTENTS

<b>Adventure Activities</b>	<b>7</b>
Level 1	15
Level 2	33
<hr/>	
<b>Aquatics</b>	<b>85</b>
Level 1	93
Level 2	115
<hr/>	
<b>Athletics</b>	<b>135</b>
Level 1	141
Level 2	157
<hr/>	
<b>Dance</b>	<b>179</b>
Creative Dance	187
Folk Dance	197
<hr/>	
<b>Games</b>	<b>205</b>
Level 1	215
Level 2	241
<hr/>	
<b>Gymnastics</b>	<b>261</b>
Level 1	267
Level 2	291
<hr/>	
<b>Health Related Activity</b>	<b>309</b>
Level 1	315
<hr/>	
<b>Resources</b>	<b>335</b>

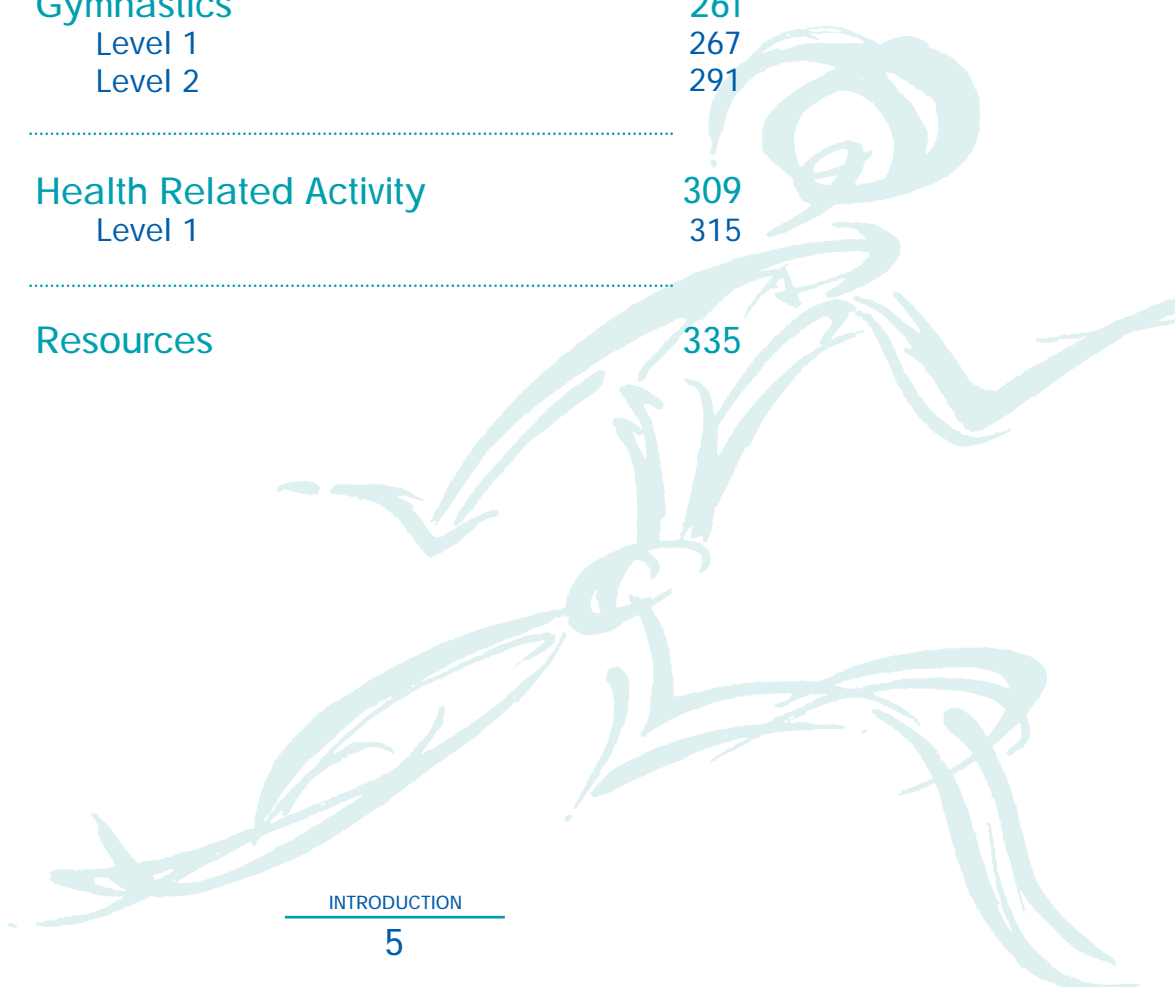





- Orienteering
- Team Challenges
- Campcraft

# Adventure Activities

*orienteering*

*navigation*      *campercraft*

*challenge activities*



# CONTENTS

Page

<b>Introduction</b> .....	<b>10</b>
<b>Overall Aim &amp; Objectives</b> .....	<b>10</b>
<b>Units of Work</b> .....	<b>11</b>
<b>Teacher Guidelines</b> .....	<b>12</b>
<b>Level One</b> .....	<b>15</b>
<i>Learning Outcomes</i> .....	16
<i>Content Framework</i> .....	16
<i>Units</i> .....	17
<i>Resource Material</i> .....	23
<b>Level Two</b> .....	<b>33</b>
<i>Introduction</i> .....	34
<i>Learning Outcomes</i> .....	35
<i>Content Framework</i> .....	35
<i>Teacher Guidelines</i> .....	36
<i>Orienteering</i> .....	37
<b>Team Challenges</b> .....	<b>43</b>
<i>Introduction</i> .....	43
<i>Menu of Activities</i> .....	45
<i>Teacher Guidelines</i> .....	46
<i>Challenge Cards</i> .....	56
<i>Team Work Card</i> .....	67
<i>Student Record Card</i> .....	68
<i>Team Report Card</i> .....	69
<i>Campcraft</i> .....	70
<i>Alternative Adventure Activities</i> .....	80



# Introduction

A variety of units are described, which are not meant to be prescriptive.

The units of work are shaped by the realities of:

- *limited budgets*
- *available physical settings*
- *the structure of school systems.*

The focus is on activities which are sympathetic to the following conditions; low resource, short time available, on site or in the immediate locality, with the minimum of additional training and can be presented in safety by the Physical Education teacher. The selected units of work outlined here are:

- *orienteeing*
- *team challenges*
- *camp craft – Bivouac.*

It is envisaged that where circumstances permit the traditional adventure activities e.g. kayaking, rock-climbing can be pursued in the attainment of level 2 aims. The material offered here is intended to provide a number of learning contexts which seek to involve the student in a sense of adventure through a spirit of co-operation and active participation.

## RATIONALE

The adventure activities presented are offered as a means of enhancing growth, self-confidence and the desire to be involved on the part of the students. Students will be confronted with their own uncertainties and fears in an atmosphere that is sympathetic and understanding. Adventure here is essentially positive in its expression and is to do with anticipation, energy and exploring the unknown, where failure is clearly possible. Students are confronted with situations where they are dependent on each other. They learn to acknowledge this reality and experience a movement away from dependence to a state of independence or inter-dependence. Adventure activity encounters offer the student an opportunity of living through situations which ultimately help them to work towards their full potential, personal, social, and physical in a safe and enjoyable environment.

## Overall Aim & Objectives

### AIM

*To challenge students by providing them with opportunities to develop personally and socially through adventure activities in a safe and enjoyable environment.*

### OBJECTIVES

- *To develop the skills and techniques which will facilitate enjoyable participation in adventure activities.*
- *To experience a range of adventure activities with a view to fostering a positive attitude towards further involvement.*
- *To develop decision-making skills, leadership qualities and an awareness of group dynamics.*
- *To develop an understanding and appreciation of the need for environmental protection.*
- *To develop an awareness of personal and group safety with particular reference to the outdoors.*
- *To assist in the development of personal and social skills.*

# Units of Work

## ORIENTEERING

Orienteering involves finding one's position and one's way with the help of a map and compass. The challenge, excitement and achievement is in finding the fastest route between a series of controls on an orienteering course. There are equal demands on physical and mental ability. Care should be taken to ensure that the courses set should match the students' age, experience and level of fitness. Orienteering can be an enriching agent for other areas of the curriculum. Concepts in mathematics, for example, such as distance, height, area and angles can be examined and tested in reality. Elements of the health related activities unit such as cardiovascular endurance can usefully be dealt with in orienteering.

## TEAM CHALLENGES

Students are engaged in significant challenges where they are required to work together as a group towards a common goal, which could not be accomplished individually. The students are confronted with real or novel problems to work with and with opportunities to undertake their own thinking and organisation. The learning context is rich with potential for social and personal growth. Success requires responsibility, co-operation, trust, leadership, resourcefulness and perseverance. There is a need to recognise, value and utilise the differing talents among the group. Through enhanced understanding and personal experiences in problem solving situations, it is envisaged that positive transfer will occur to other life situations.

## CAMP CRAFT/BIVOUAC

Through living and moving in the outdoor environment, students are introduced to the realities of sustaining independent travel. The students are acquainted with the skills and considerations which enable them to accommodate themselves effectively in the outdoors. Careful handling of equipment, selection of campsite or bivouac site and the concern and respect for the natural environment are central to this unit.

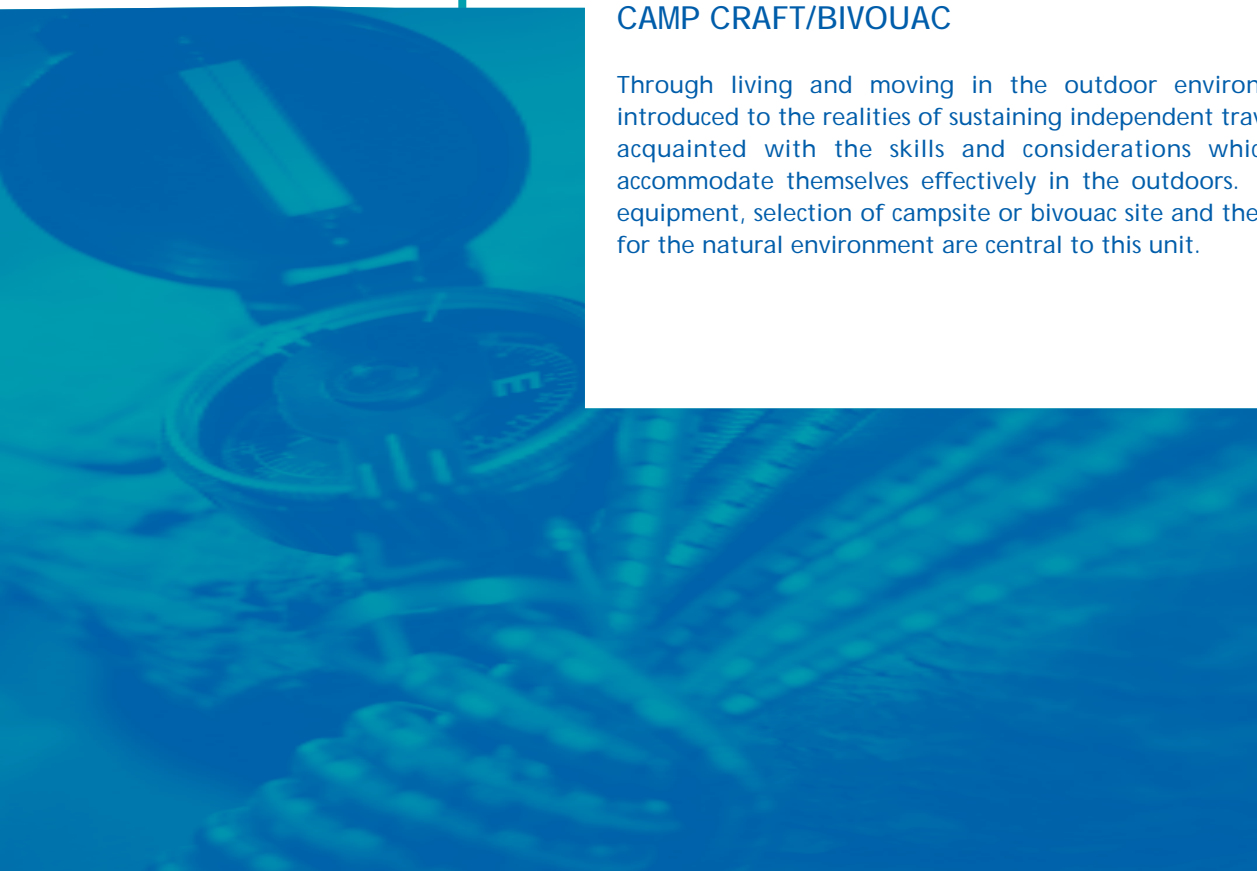

# Teacher Guidelines

Teachers are recommended to devise an adventure activities course at level 1, based on the units of work provided here, i.e., orienteering, team challenges and campcraft. These form a foundation for all adventure activities in focusing on navigation, teamwork and accommodation in the outdoors. Opportunity to include some of the traditional outdoor pursuits is provided at level 2. Care should be taken that no one component/pursuit would command a time allocation which would limit the student's experience of a broad range of outdoor educational experiences.

A water based activity while desirable may not be a viable consideration for inclusion in the devised course. Where possible efforts should be made to include a water based activity for example within a residential experience or on a day activity visit.

The residential experience is regarded as of significant value to the effectiveness of the unit. It is recommended that two days and one night would be a minimum requirement.

Where possible the students should be involved in the planning and the preparation of activities. The sense of ownership thus created will lead to greater commitment and participation by the students.

Imaginative use should be made of the school environment and immediate locality. Students should be confronted by a reasonable level of perceived risk, adventure and a degree of challenge which will promote their enthusiasm. The natural environment including the dark, woods, rocks and water involve sufficient challenge and mystery in themselves, if they are presented imaginatively.

A number of activities are included which may enhance the development of the adventure activities modules. These will be particularly useful on occasions of inclement weather and in situations where the teacher wishes to develop a clearer understanding of specific aspects of orienteering.

Every effort should be made to ensure the student has an educational, enjoyable, safe and challenging experience. Activities undertaken should be of real educational value and should relate to the ages, aptitudes and abilities of all the children taking part.

Teachers may seek to avail of the support of individuals with particular qualifications/skills in adventure activities be they within the school community, in the immediate locality or at certified centres of outdoor education.

Activities outside the range prescribed in the adventure activities module) orienteering, team challenges and campcraft) must be provided by suitably qualified personnel.

Learning may be enhanced where adventure activities are integrated with other areas of the curriculum, for example adventure activities provide many opportunities for the development of health related concepts.

An awareness of the need to care and be concerned for the natural environment, together with personal and group safety are linking themes throughout the activities.

The learning experience is enhanced where elements of the various components are integrated.

## ***The Colour Coded System***

The level of difficulty of courses offered on an orienteering event is denoted by a colour coded system. The progressive level of difficulty moves initially from white, to yellow to orange.

We have adopted this system into the team challenge bank to select tasks (activities) appropriate to the class grouping.

For explanation of the terms 'major' and 'minor' see page 34.

The following is a suggested structure for the Adventure Activities areas (excluding any residential experience).

### **Level 1**

*Integrated module.  
One activity as a major aspect and an introduction to two other areas of adventure activities linked to this major aspect e.g. orienteering with links to camp-craft and team challenge.*

### **Level 2**

*Integrated module.  
One activity as a major option and one other as a minor option.*



## AREAS OF CONTENT

### Level 1

---

- At this level the emphasis is on participation and enjoyment. Students are introduced to the basics of adventure activities through orienteering, team challenges and campcraft.
- Where possible students should have opportunity to experience other activities, e.g. hillwalking, rock climbing, kayaking, sailing, snorkelling, surfing, caving.
- Through their participation, students should recognise the need for appropriate personal equipment and safety precautions.

### Level 2

---

- At this level the emphasis is on developing and refining students' skills and on promoting more active involvement in the decision-making processes.
- Students will take responsibility for the planning and preparation of a residential experience.
- During their stay, an important facet of the experience will be the development of students' ability to participate as part of a team e.g. solving problems as a group, taking responsibility for food preparation and other organisational duties.
- Students will develop an awareness of important environmental concerns e.g. pollution and it's effects on natural habitats, erosion on hill walking routes, the country code.
- Students will reflect on experiences, giving them an insight into positive group and individual action and into students' personal strengths and limitations.

## ASSESSMENT PROCEDURES

---

<b>Cognitive</b>	Structured observation Unstructured observation Oral questioning Written assignment
<b>Affective</b>	Observation Student profile Informal interview
<b>Psychomotor</b>	Practical assessment Observation Log Book

## STUDENT PORTFOLIO

---

Evidence of learning in the three domains to be included in a student portfolio.

The student's portfolio may contain;

- **evidence of learning** *This may comprise specialised equipment related to activities, photos, drawings, record cards and logbooks*
- **self assessment** *Proforma supplied*
- **teacher observation**
  - *Competence*      • *Perseverance*
  - *Readiness to work in a group or independently as required*
  - *Co-operation*      • *Enjoyment*      • *Participation*





# Adventure Activities



Level  
One

# Learning Outcomes

The student will;

- *experience a variety of land and water based activities*
- *achieve a level of technical competence commensurate with their level of experiences and potential*
- *demonstrate an understanding of the need for safety procedures, both personal and group*
- *appreciate the necessity for appropriate personal equipment*
- *develop a respect for the natural environment with an understanding of important environmental issues*
- *demonstrate responsible personal and social behaviour in adventure activity settings*
- *reflect on and evaluate adventure experiences.*

## GENERAL EQUIPMENT LIST

- Map of school grounds
  - Cones
- Control cards
- Tracing paper
  - Time clock
  - Clipboards
  - Sticky labels
- Planks of wood 2 x 2.44m (50mm x 100mm)
  - 4 lengths of rope (2.5m – 4.25m)
- 4 rubber tyres (check for exposed wires)
  - Gym mats
  - Hoops
  - Benches

## CONTENT FRAMEWORK

	OBJECTIVES	CONTENT
Unit 1	The student will: <ul style="list-style-type: none"> <li>• associate shapes on map with objects on the ground</li> <li>• set map and establish direction of travel</li> <li>• recognise orienteering symbols</li> </ul>	<ul style="list-style-type: none"> <li>• Map drawing</li> <li>• Map setting</li> <li>• Symbol recognition</li> </ul>
Unit 2	<ul style="list-style-type: none"> <li>• orientate map by using the landscape</li> <li>• relate features on the landscape to features on the map and vice versa</li> <li>• work as a team member to devise a solution to a team challenge</li> </ul>	<ul style="list-style-type: none"> <li>• Terrain walk</li> <li>• Feature identification</li> <li>• Team challenge (tank tracks)</li> </ul>
Unit 3	<ul style="list-style-type: none"> <li>• apply safety procedures when undertaking a team challenge</li> <li>• identify an effective procedure when undertaking a team challenge</li> <li>• recognise the main landscape features necessary to locate the controls</li> </ul>	<ul style="list-style-type: none"> <li>• Team challenge</li> <li>• Star event</li> </ul>
Unit 4	<ul style="list-style-type: none"> <li>• list and discuss elements of the country code</li> <li>• identify and demonstrate a procedure for erecting and striking a tent / shelter</li> <li>• Develop teamwork and communication skills</li> <li>• review the procedure for effective teamwork</li> </ul>	<ul style="list-style-type: none"> <li>• Country code</li> <li>• Erecting a tent / shelter</li> <li>• Team challenge (Teamwork walk)</li> </ul>
Unit 5	<ul style="list-style-type: none"> <li>• be able to identify handrail features</li> <li>• demonstrate continuous map contact and detailed navigation</li> <li>• identify the procedures related to participation in a recognised orienteering event</li> </ul>	<ul style="list-style-type: none"> <li>• Hand rails</li> <li>• Line event</li> <li>• Event procedure</li> </ul>
Unit 6	<ul style="list-style-type: none"> <li>• apply orienteering skills to complete a cross country orienteering event.</li> </ul>	<ul style="list-style-type: none"> <li>• Cross-country and Orienteering event</li> <li>• Assessment</li> </ul>

## Unit 1: Navigation (Orienteering)

### LEARNING OUTCOMES



- The student will:**
- associate shapes on the map with objects on the ground
  - set the map and establish the direction of travel
  - recognise orienteering symbols.

### EQUIPMENT

Masterplan, route cards, clipboard, paper, pencils, erasers, 9 big cones and 9 sticky labels, range of apparatus for map drawing, North arrow, black / white board, sticky tape.

### CLASS ORGANISATION

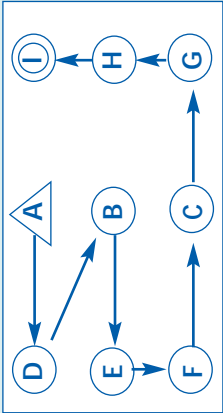
Sports hall or outside play area.

STAGE	CONCEPT	CONTENT / ACTIVITY	TEACHING POINTS
<p><b>Warm up Introduction</b></p>	<p>Map drawing Scale Plan</p> <p>Extension 1a</p>	<p>In pairs, draw map of hall. Identify position, scale and orientation of items of equipment.</p> <p>Map drawing with 5 identical objects.</p> <p>Drawing a map from a picture (see resource sheet pg. 23).</p>	<ul style="list-style-type: none"> <li>• Review maps - scale, placement, shape.</li> <li>• Discuss relationship between symbols and actual objects.</li> </ul> <p>Is this shape correct? What is its size in relation to the room? Does it look right?</p> <ul style="list-style-type: none"> <li>• Clipboards facilitate drawing.</li> <li>• Use limited number of items.</li> </ul>
<p><b>Development</b></p>	<p>Setting the map</p>	<p>Mark 9 road cones with symbol/letter. Set out to a master plan (as shown).</p>  <p>Students who follow route correctly should have symbols/letters in correct order.</p> <p>Reduce number of cones to 6. Students draw a route and identify correct code sequence. Challenge each other or another group</p>	<p>Teachers should;</p> <ul style="list-style-type: none"> <li>• Have a prepared set of route cards. See resource material.</li> <li>• Emphasise 'thumbing' the map.</li> <li>• Check answers.</li> </ul> <ul style="list-style-type: none"> <li>• Where are you now?</li> <li>• Is your map set?</li> <li>• Where are you going next?</li> </ul> <p><b>General Points</b> Stick labels inside cones. Describe setting procedure Ensure N is visible.  = start  = finish</p>
<p><b>Conclusion</b></p>	<p>Symbol recognition</p>	<p>Present range of orienteering symbols. Request interpretation. Reveal recognised interpretations.</p>	<p>Teams of 4-6. Page of symbols and page of descriptions (resources).</p> <p><b>ASSESSMENT</b> Observation. Compare student maps with master. Check codes against correct sequence. Recall of setting procedure. Portfolio - include student maps.</p>

Unit 2: Navigation, feature identification and team challenge

**LEARNING OUTCOMES**

**The student will:**

- orientate a map by using the landscape
- relate features on the landscape to features on the map and vice versa
- work as a team member to devise a solution to a team challenge.

**EQUIPMENT**

School ground map, control cards, laminated maps for feature identification controls, pencils, paper and tracing paper, master map - map per pair (one control point marked on each map), clipboards, team challenge cards, mats.

**CLASS ORGANISATION** School grounds

STAGE	CONCEPT	CONTENT / ACTIVITY	TEACHING POINTS
Warm up/ Introduction	Setting map while on the move Thumbing the map Relating map to ground	Terrain walk Assemble outside. Identify main features. Set map and locate position. Practise setting map while facing different directions.	Ensure students set map before moving off. How do you know your map is set?  Walk with students – stop frequently to establish location. Practise setting technique and thumbing. Your thumb should indicate your present location.
Development	Feature identification	Orienteering Each student has a map. Teacher marks control site on maps. Students place one control at the location identified on their map. On return they hand in the map and draw their own sketch map of the control.  The sketch maps are exchanged and the students collect the control using their new map.	Identify the cardinal points N.S.E.W.
Conclusion		Team challenge — tank tracks pg. 56	All information regarding team challenges is contained in the level 2 section.  Allocate starting point and finish Outline task – distribute challenge card. Provide guidance if required.

## Unit 3: Navigation / team challenges

### LEARNING OUTCOMES

#### The student will:

- apply safety procedures when undertaking a team challenge
- identify an effective procedure when undertaking a team challenge
- recognise the main landscape features necessary to locate orienteering controls.

### EQUIPMENT

Control card, star event control maps, control punches, cones.

### CLASS ORGANISATION

School grounds.

STAGE	CONCEPT	CONTENT / ACTIVITY	TEACHING POINTS
Warm up	Safety	Team challenge Choose 2 from team challenge bank. (menu of activities pg. 46)	What are the potential dangers? What safety precautions are necessary? Ensure that students are alerted to hazards and are aware of each others safety.
Development	Participation in event – setting and thumbing	Star event Students visit 1 control only and return to base. Then they are allocated next control.  If group is experiencing difficulty walk the group through star event. For more able students use different combinations and directions within the star and / or longer distances, more difficult control sites.	Assist less able students to draw maps and hang controls. Teacher remains at centre. All movement originates from here. Ensure map is set.  See support material pg. 25

## Unit 4: Campcraft / team challenge

### LEARNING OUTCOMES

- The student will:**
- list and discuss the elements of the country code
  - identify and demonstrate a procedure for erecting and striking a tent / shelter
  - develop team work and communication skills
  - review the procedure for effective teamwork.

### EQUIPMENT

See resource material for details.

### CLASS ORGANISATION

School grounds.

STAGE	CONCEPT	CONTENT / ACTIVITY	TEACHING POINTS
Warm up Introduction	Country code	Students agree a code of behaviour to protect the environment.	Brainstorm Compare with country code
Development	Erecting a tent / shelter	Identify requirements of efficient campcraft. (shelter / comfort / food / safety / warmth etc.). Students erect a shelter / tent or emergency shelter in groups of 4. Strike tent, clean and store.	
Conclusion	Team challenge Team work Communication skills	Choose from team challenge bank. Teamwork walk pg.62.	Identify a time frame.  Good communication depends on: <ul style="list-style-type: none"> <li>• clarity of instruction</li> <li>• good listening</li> <li>• clarification</li> <li>• knowledge of the task.</li> </ul> Provide each group with a challenge card.  Review, discuss difficulties encountered. Complete report form for inclusion in portfolio

Lesson 5: navigation / event procedure

**LEARNING OUTCOMES**

- The student will :**
- be able to identify handrail features
  - demonstrate continuous map contact and detailed navigation
  - identify the procedures related to participation in a recognised orienteering event.

**EQUIPMENT**

Laminated maps controls, punches(optional), pencils, red pens, paper, master maps-line event/control sites. clipboards posters/overhead.

**CLASS ORGANISATION**

School grounds

STAGE	CONCEPT	CONTENT / ACTIVITY	TEACHING POINTS
Warm up Introduction		<p>Hand rail</p> <p>Students identify features on the map which could act as handrails.</p> <p>Students identify hand-rails for specific 'legs' of a course e.g. from no.4 to no.5.</p>	<ul style="list-style-type: none"> <li>• Identify handrail features</li> <li>• Explain purpose of handrails (Refer to support material for unit 5 pg. 28)</li> </ul>
Development	Control location	<p><b>Line orienteering event</b></p> <p>Each pair of students has a map with a route marked on it but with no controls marked on it.</p> <p>Each pair must follow a prescribed route /line. Controls are placed along the line in locations unknown to the students.</p> <p>Each pair must identify the control sites by circling these on their maps.</p>	<p>Continuous map contact required thumbing and setting essential.</p> <p>Circles must be precise, not too large or too small.</p> <p>Punch or code may verify the students completion of task.</p> <p>Good evidence of navigation skill.</p> <p>For more advanced groups students may work alone or may cover greater distances</p>
Conclusion	Procedural knowledge of a recognised event  Homework	<p>Task: Students design a poster or information leaflet detailing an upcoming event using the following headings:</p> <ul style="list-style-type: none"> <li>• Event Calendar</li> <li>• Direction</li> <li>• Clothing</li> <li>• Specific equipment</li> <li>• Registration</li> <li>• Control card</li> <li>• Start / Finish</li> <li>• Results</li> </ul>	<p>Local orienteering clubs may provide examples of these resources.</p> <p>For inclusion in portfolio.</p>

## Unit 6: Orienteering

### LEARNING OUTCOMES

- The student will:
- apply orienteering skills to complete a cross-country orienteering event.

### EQUIPMENT

Mini-markers, controls, punches, master maps, course cards, time clock.

### CLASS ORGANISATION

Area mapped for orienteering.

STAGE	CONCEPT	CONTENT / ACTIVITY	TEACHING POINTS
<p><b>Warm up Introduction</b></p>	<p>Cross-country orienteering event</p>	<p>Each student has a master map with 20-25 controls pre-marked.</p>	<ul style="list-style-type: none"> <li>• Apply the event procedure clearly and methodically.</li> <li>• Have an example of a control.</li> <li>• Select a course.</li> </ul> <p>Skills to be reinforced:</p> <ul style="list-style-type: none"> <li>• map orientation</li> <li>• thumbing map</li> <li>• recognition of orienteering symbols</li> <li>• following a route</li> <li>• use of handrails</li> <li>• standard procedure for all Orienteering events</li> <li>• recognition of and adherence to country code.</li> </ul> <p>Each course has 5 control points. There are 5 different courses. Teacher has control descriptions for each course. Each student completes a control card. Controls must be visited in the correct order. A code / symbol / punch registers the students visit to the control point. Students verify and calculate their time on each course.</p>
<p><b>Development</b></p>	<p>Cross-country Orienteering</p>	<p>Students are allocated a course. They may be set-off clockwise and anti clockwise. On return, the course is returned to it's base and following presentation of the control card to the teacher for checking, another course may be allocated.</p>	<p>Allow 2 minute intervals. 5 students may be set off at a time. 5 courses.</p>
<p><b>Conclusion</b></p>	<p>Extensions</p>	<p><b>EXTENSIONS</b></p> <p>(i) Students compete with each other, one going clockwise the other anti-clockwise.</p> <p>(ii) Map memory - the students have to remember the location of all five control points and may not carry a map with them. (W) course may be walked in pairs. Mini-controls demand finer navigation.</p> <p>(iii) Attend a recognised orienteering event.</p>	<p>Codes must be checked to ensure correctness. Calculations of times and tables of results might be completed in co-operation with the maths teacher.</p>



Resource material: Orienteering - Extension 1a

### MAP SETTING

This exercise is designed to assess the student's understanding of map setting and his/her ability to keep the map orientated correctly as he/she follows a route. The teacher is able to observe all of the group in a small area and to instruct as needed.

### ORGANISATION

Arrange nine large cones in three rows in an area outside or in a large hall. Draw up a set of route sheets identifying a number of different routes which must be followed. The routes will require the student to travel from one cone to the next in a particular order. On the teacher's master map identify the letter allotted to each cone. The cones must be set out in this order at a distance not less than 5 meters apart. Ensure that "N" is visible on one side of the hall. The map will be orientated to this direction.

Duplicate a set of route sheets, one per pair. Draw 4 different routes in different colours. Copy each route 10 times. Choose a different start and finish point for each route. Place each set in a separate box.

To each feature on the map is attached a sticker with a code/letter/symbol. Students work in pairs.

1 = Map reader 2 = Recorder

They must fill in the codes in the correct order on their cards as they go. On completion of one course another coloured route is selected.

### TEACHER NOTES: - TEACH SETTING TO "N"

- Introduce students to the practice of walking with the map set.
- Thumbing to identify present location.
- Review the questions which the orienteer must ask,
  - Where am I now ?
  - Is my map set ?
  - Where am I going next?
  - Which direction is it?
- Ensure that each group has a sheet / route card on which to record the letters on their route.
- Pencils and paper will be needed.
- The start will always be indicated by .

### DRAWING A MAP FROM A PICTURE

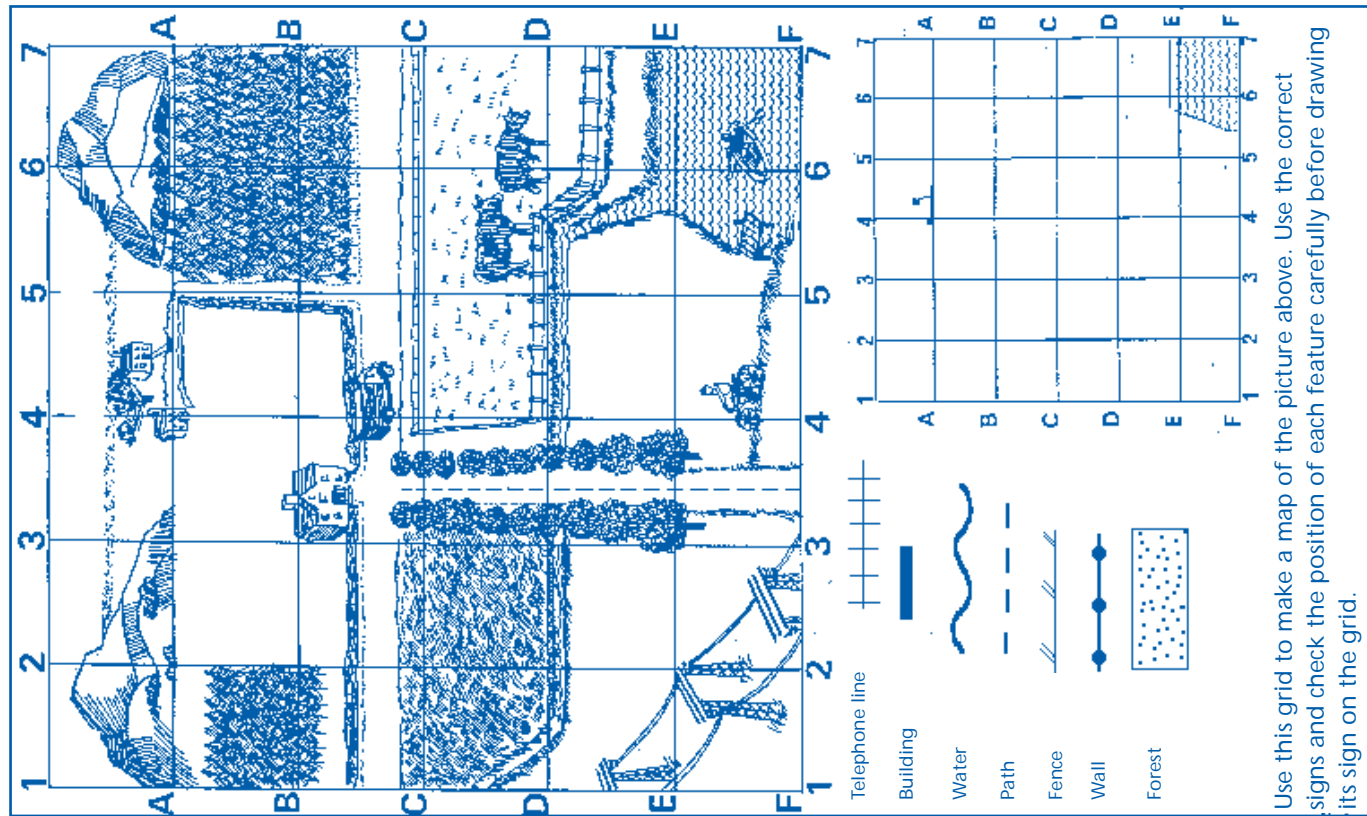

Use this grid to make a map of the picture above. Use the correct signs and check the position of each feature carefully before drawing its sign on the grid.

## SYMBOL RECOGNITION

### Alternative / additional symbols used in orienteering maps

Symbols for a black and white orienteering map

-  Tarmac road
-  Large track
-  Large footpath
-  Small footpath
-  Building
-  Wall
-  Fence, gate
-  Uncrossable fence
-  Hedge
-  Steps
-  Individual trees
-  Football posts
-  Man made object (e.g. post, light, seat, sign, etc.)
-  Stream or ditch
-  Steep slope
-  Pond
-  Glasshouse
-  Open land
-  Tarmac surface
-  Paved area
-  Trees

### PREPARATION

Draw a grid on each of the two pieces of card. Each section of the grid should be the same size, e.g. 7cm x 10cm.

On one sheet draw or stick the map symbols. On the other sheet write the names of the symbols.

Cut out the sections to make two sets of cards.

Dirt Road	Track	Path	Road
Wall	Fence	High Fence	Ruined Wall
Stream	Ditch	Marsh	Lake
Building	Ruin	Open Land	Distinct Vegetation Change

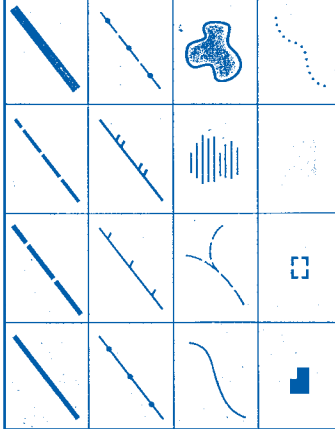

### PROCEDURE

Initially these card games are best presented as a set exercise. When students are aware of the requirements of each set, the basic knowledge needed and the purpose of each game the card games can be developed into relay type activities or become part of an orienteering fitness circuit.

### GAMES

Mix up and lay out the pieces keeping the symbols separate from the names. The students match the symbol with the name as quickly as possible. This can be done sitting or running. Work individually or in pairs.

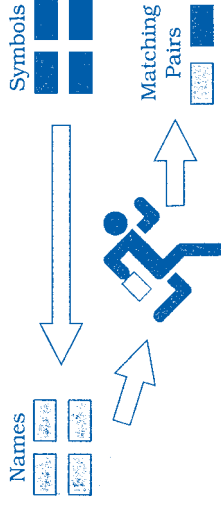

### SYMBOL RELAY

There are several card games which can quite usefully be used to improve the student's familiarity with maps and symbols and also to identify strategic decision making which needs to be undertaken by the orienteer.

A sufficient quantity of sets of cards will need to be drawn up to accommodate a large number of students. This can be accomplished with the help of your students by working from a master copy or template. Colour coding will assist in the identification of differing tasks or matching sets. Be sure to retain a master copy with the correct solutions to speed checking and correction. Sets of used orienteering maps can be obtained from your local orienteering club.

Set A: Map symbol + Identification

- Forest path
- D Building

Set B: Map jigsaws

Piece together the maps to match the original.

Set C: Map pieces

Two of the same map are cut identically. The student is required to match the similar pieces. One set marked by number and the other by alphabet will assist in the checking.

Set D: Map and Photograph

The student is required to match the section of the map presented with the photograph which represents that section.

Resource material: Unit 3

**STAR EVENT**

In this event -  
All students return to a central point following each control.

This is an excellent activity which allows for continuous supervision, and regular contact with the students to enable instruction.

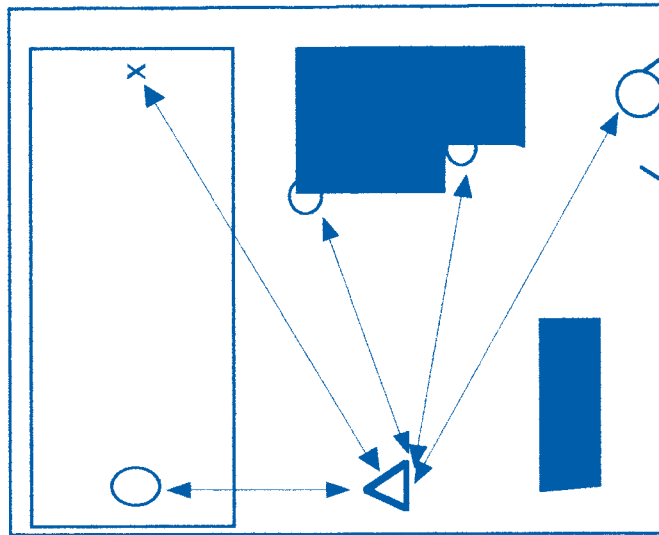

**TEACHER NOTES:**

Select a good location for the base offering good vision of the class, a range of control sites and adequate space.  
Draw up a master map, identifying all control sites.  
Use permanent features initially.  
Each map should identify the starting point  and only one control site.  
Make 4 copies of each map.

**ORGANISATION: - DEMONSTRATE CONTROL PUNCHING.**

- Demonstrate setting the map. Align with the largest feature.
  - Check symbol recognition on the map with features on the ground.
  - Explain the procedure as follows.
    - Students work in pairs. Line up at the starting point.
    - Students are allocated a map or select a map.
    - They set the map, decide the direction of travel and location of the next control.
    - They then run to the control, punch their card and return to the base.
- They must then queue up behind another control map.

**EXTENSIONS: - CONTROLS FURTHER AWAY, OUT OF VIEW.**

- Two controls marked on each map.
- May be used as a relay race (aerobic fitness).

Resource material: Unit 4

**ACTIVITY**

- Divide the class into three groups.
- Each group is given a number of items with which to build a shelter / tent.
- Establish a time limit.
- Review: Is the shelter safe / effective?  
Are there any ways in which it could be improved?

**SHELTER 1**

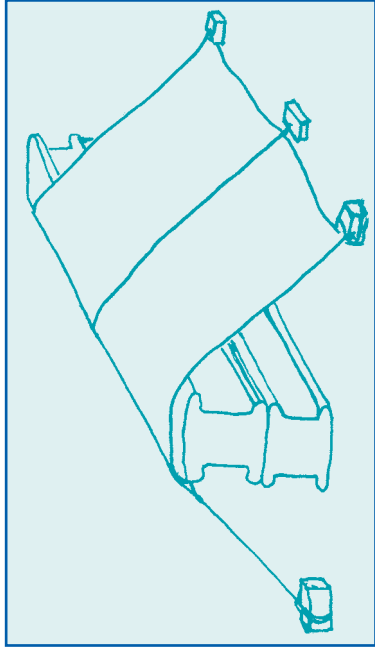

- Resources:
- 4 refuse sacks (cut open)
  - 6 light weights
  - 2 benches
  - A number of lengths of rope.
- \* Don't allow weights to be placed on top of the bench.

**SHELTER 2**

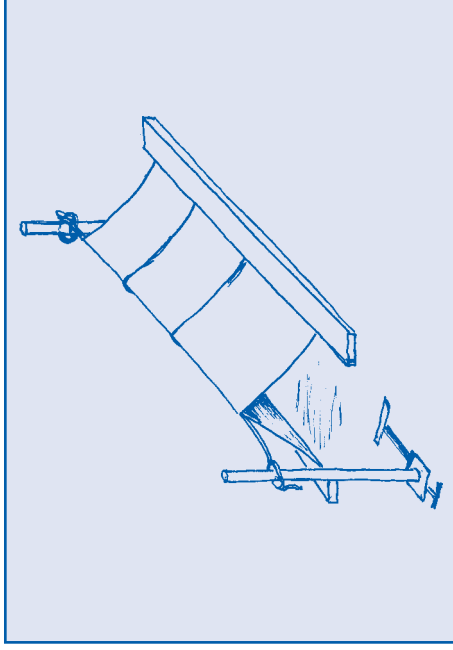

- Resources:
- 3 bivy bags
  - 2 badminton stands
  - 2 planks
  - 1 length of rope.

**SHELTER 3**

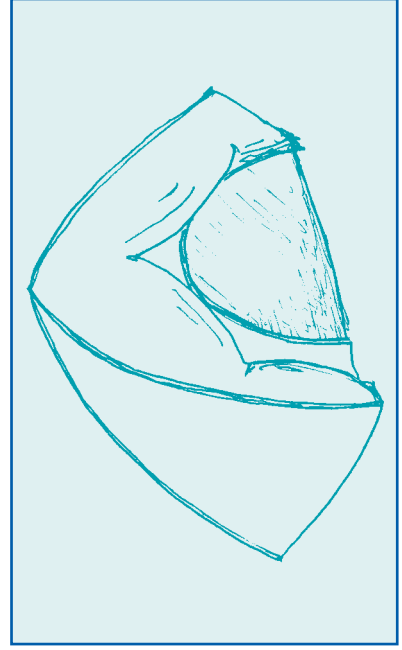

- Resources:
- 1 tent
- Use a free-standing tent if possible, e.g. dome tent

# Country Code

Leave livestock, crops and machinery alone

Take your litter home

Make no unnecessary noise

Help to keep all water clean

Guard against all risk of fire

Fasten all gates

Keep your dogs under close control

Keep to public paths across farmland

Protect wildlife, plants and trees

Take special care on country roads

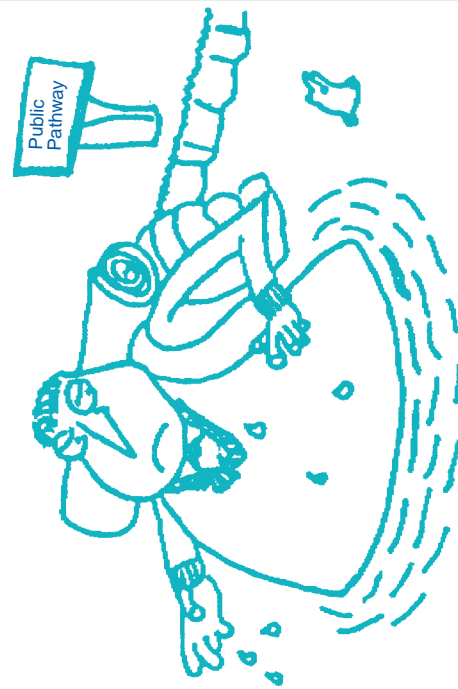

Resource material: Unit 5

### LINE ORIENTEERING

This exercise may be used to develop the student's confidence in fine map-reading and in relating the map to ground. The task set will also serve to inform the teacher of the level of successful map-reading being achieved.

A line is drawn on the map following line features or joining distinctive features. The teacher has a corresponding map which will have identified the location of a number of control points on this line. The students will be unaware of the location of these control points.

### ORGANISATION

Each student is allocated a map on which a line has been drawn identifying the course which must be followed closely. Along this route he/she will encounter a number of controls, the position of which must be circled accurately on his/her own map. A 2 min. interval should be allowed between students as they are set off.

### TEACHER NOTES

A punch or code will serve to confirm the student's presence at each control site. An example of a control circle should be given to avoid control circles being drawn which are too large or too small. Indoor orienteering games would provide useful exercise for those who are waiting to go out on the course. A template with the correct control locations would allow for quick correction.

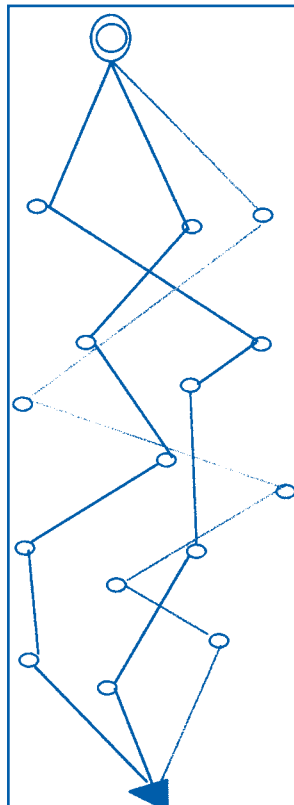

### HANDRAILS

A handrail is any line feature such as a path, earthwall, stream, fence, which will provide the orienteer with a secure point of reference as he moves from one control point to another.

Navigational problems can be simplified by using handrails and can result in improved confidence and performance.

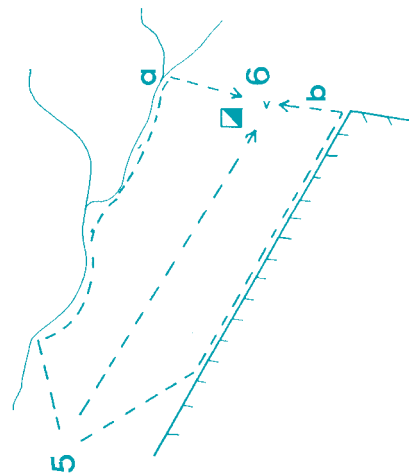

### EVENT PROCEDURE



**Orienteering gear: Check list:** Compass, Map case, Red biro, Whistle, Safety pins, Tape, Full body cover (old track suit legs, long sleeved shirt,) Gaiters, Studded orienteering shoes, watch.



**Registration .** Select course appropriate to age and experience. (sometimes colour coded). Purchase map. Obtain control card, description sheet.



**Preparation.** Transfer description sheet details to control card. Complete control card requirements. Seal control card if conditions are wet. Attach control card to shirt ,sleeve or front. Tape laces. Identify " Out of bounds " areas or map corrections. Check compass,whistle, red pen, map in map case.



**Start :** Acquire a start time. Go to starting point and await time being called. Present control card stub. Proceed through time waiting zones. Go to appropriate master map to transfer course.











**Finish :** Hand in control card at the finish. ( Irrespective of completion or non-completion of the course.)



**Review**

## LEGEND

- Buildings 
- Path 
- Object 
- Wall 
- Boulder 
- Single Tree 
- Shrubs 
- Uncrossable fence 
- Steps 



Sample School Map

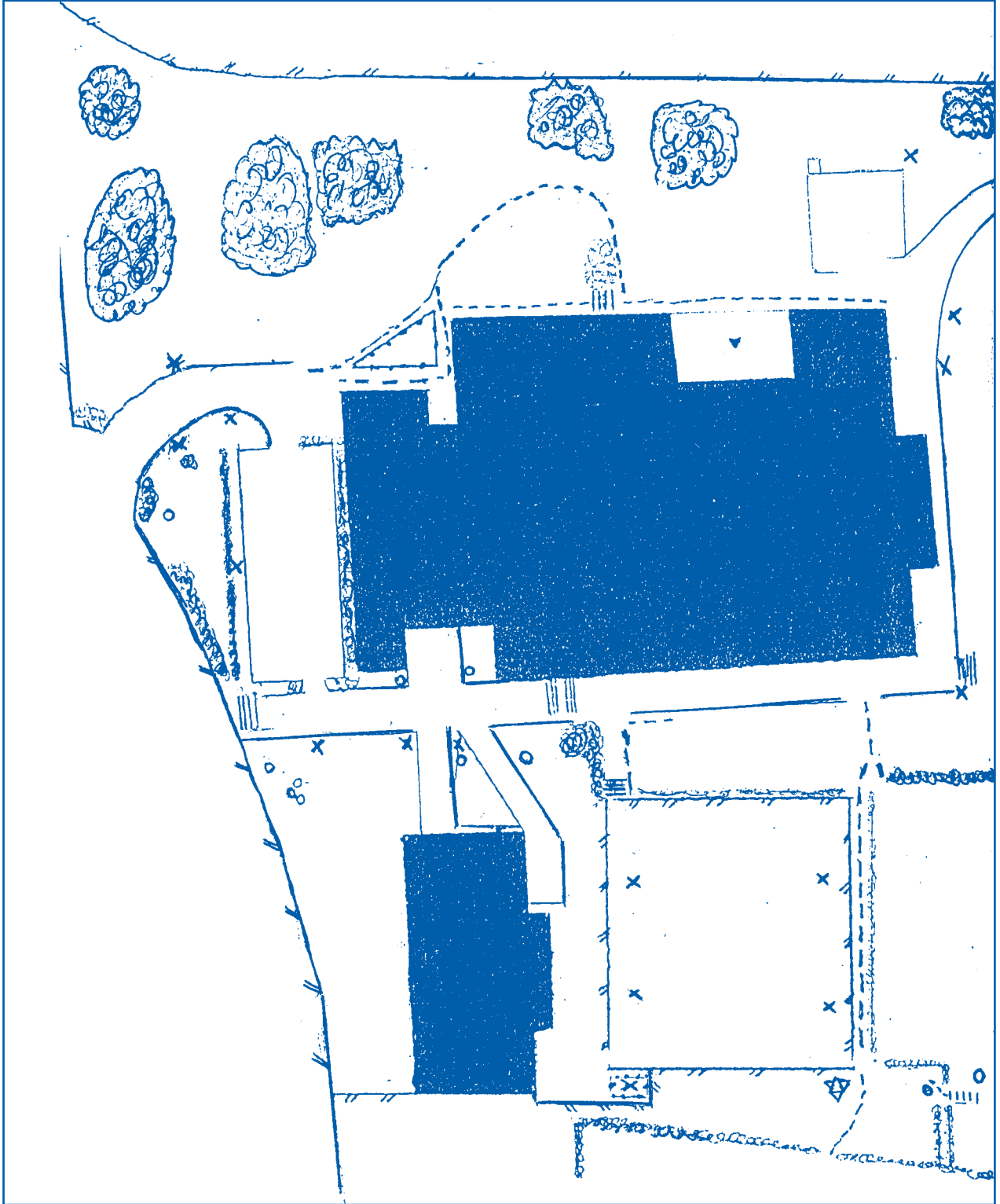

## Resource material: Orienteering

The physical resources required to enable the teacher to present orienteering as an element of the physical education programme are quite minimal and relatively inexpensive. Initially, time will be needed to get together the various items such as laminated maps, mini controls, permanent course, punches, card games, but once in place they become a constant resource readily accessible.

**The Map:** The map is fundamental to the sport of orienteering. In general a simple black and white map will be adequate to meet the basic requirements of orienteering at an introductory level. The quality and detail of the map will depend on the amount of time and finance you can allot to it. A number of options are available:

- A simple freehand sketch offering a close representation of the school grounds.
- A photocopy from a large scale ordinance survey map or architect's plan. Using this as a base, place drawing film or tracing paper over and fix in place securely. Typical orienteering features will need to be added e.g. single trees, posts, hedges etc. It will be necessary to ensure that the map is still accurate
  - walls and newer buildings may have been added since surveying
  - through corrections and additions.
- Many distinctive features may be quite accurately plotted by eye. Colour could be added before use. Remove the drawing film or paper and photocopy. Permission may be necessary from various sources e.g. Board of Management, Local Authority.
- A professionally drawn map may be surveyed and drawn by your local orienteering club. Local community organisations or businesses may be willing to sponsor the cost of this venture.
- All maps should be to a large scale suitable to fit onto an A4 page. A clear orienteering legend of symbols should be attached. A north arrow should be added to enable the development of compass work. Should you consider laminating, you may wish to draw a permanent course onto each map and to attach a copy of a local woods to the back before laminating.

**Control markers:** The large orange and white orienteering control is too conspicuous for the school grounds and diminishes the navigation needed. Mini controls are more suitable. These could be made of plastic, plywood or metal. In the case of permanent courses these would be drilled to allow for fixing and attaching punches. A code, or symbol would be drawn onto each control. The controls would be fixed to posts or walls at various points around the school grounds.

**Control cards:** Proper control cards can be obtained from your local orienteering club. It is important that the student is aware of how to complete this card. Copies of this can be drawn or photocopied as required.

**Compasses:** Compasses are not required at level 1 but are an integral part of navigation practice and will be required for later exercises.

## GLOSSARY

**Aiming off:** to aim deliberately to one side of a control on a line feature so that you know which way to turn on hitting the feature before seeing the control.

**Attack point:** an obvious feature near a control point from which the control can be located by navigating carefully with map and compass.

**Collecting feature:** a feature beside a route which can be used to simplify navigation and 'contain' any diversion from the correct route.

**Figure:** an area of thick vegetation or forest through which it is difficult to pass - shown as dark green on an orienteering map.

**Leg:** a section of a course between two control points.

**Ride:** a grassy or rough linear break between trees.

**Score orienteering:** a competition to find as many controls as possible in any order, and in a fixed time, with penalties for lateness.

**Vegetation boundary:** the line between two distinct types of vegetation shown by a dotted line on maps.



# HOW AM I DOING?

Student Name .....

Class .....

Date .....

I can set my map by matching it to the terrain .....	Yes <input type="checkbox"/>	No <input type="checkbox"/>	
I can select appropriate collecting features .....	<input type="checkbox"/>	<input type="checkbox"/>	
I know what the different colours mean .....	<input type="checkbox"/>	<input type="checkbox"/>	
I can recognise the different vegetation .....	<input type="checkbox"/>	<input type="checkbox"/>	
I know what to do when I get to an event before I can start .....	<input type="checkbox"/>	<input type="checkbox"/>	
I can fill in my control card properly .....	<input type="checkbox"/>	<input type="checkbox"/>	
I kept thumbing the map .....	Often <input type="checkbox"/>	Sometimes <input type="checkbox"/>	Never <input type="checkbox"/>
I checked off features as I came to them .....	<input type="checkbox"/>	<input type="checkbox"/>	<input type="checkbox"/>
I used my pace counting on route .....	<input type="checkbox"/>	<input type="checkbox"/>	<input type="checkbox"/>
I followed other runners .....	<input type="checkbox"/>	<input type="checkbox"/>	<input type="checkbox"/>
I took a chance .....	<input type="checkbox"/>	<input type="checkbox"/>	<input type="checkbox"/>
Other runners followed me .....	<input type="checkbox"/>	<input type="checkbox"/>	<input type="checkbox"/>
I didn't follow the planned route .....	<input type="checkbox"/>	<input type="checkbox"/>	<input type="checkbox"/>
I was exhausted .....	Yes <input type="checkbox"/>	No <input type="checkbox"/>	
I would prefer to be with a partner.....	<input type="checkbox"/>	<input type="checkbox"/>	
It was, ok <input type="checkbox"/> cool <input type="checkbox"/> a drag <input type="checkbox"/>			
I was afraid of getting lost .....	<input type="checkbox"/>	<input type="checkbox"/>	
I would try orienteering again .....	<input type="checkbox"/>	<input type="checkbox"/>	

Well Done!

Resource material: Indoor orienteering activities

CONCEPT	CONTENT / ACTIVITY	TEACHING POINTS
Symbol Relay	<p>Teams match symbols with descriptions at another site.</p> <p><b>W</b> Limited number of symbols, with list provided</p> <p><b>Y</b> No list provided</p> <p><b>O</b> Greater distance to be covered, less time</p>	<p>Resources: Pack of cards for symbol relay.</p>
Map orientation Relating map to the ground	<p>Identify correctly orientated map from a landscape scene and series of maps.</p>	<p>Identify features which help the student to select foreground, background, shape, relationship.</p> <p>Key questions:</p> <ul style="list-style-type: none"> <li>• What are the particular shapes on the map?</li> <li>• What features are in the foreground / background?</li> <li>• Why did you choose that position?</li> </ul>
Extension Map memory	<p>Map memory games. These activities can be static at first and later can be made to incorporate more activity.</p> <p>Look at the control site - write down the control description. Copy orienteering course from a master map onto a clear map. In pairs - A describes the location of control on a master map to B who transfers the course onto a blank map.</p>	<p>Identify the cardinal points N.S.E.W. Demonstrate on an overhead. Give examples of control descriptions.</p> <p>Memory games generate active participative lesson. Assessment: Team Report Card.</p>

# Adventure Activities



Level  
Two

# Introduction

Level 2 adventure activities builds on the experiences, skills and knowledge gained at level 1. It is recommended that two activities be undertaken at level 2, one as a minor option and the other as a major option. These terms are indicative of the time the activities are allotted and the level of achievement to be attained. The minor option receives one third of the class time, while the major option receives two thirds. It is understood that the minor objectives are achieved as part of the major option.

To allow for variations in resource availability, student ability and teacher expertise, there is greater opportunity for teacher discretion with regard to choice of activities at level 2. Hence, a menu of activities is provided for the three components provided here. The teacher can design a programme most suited to the individual teaching situation by linking the objectives listed, with the activities outlined in the teaching package.

Orienteering, team challenges and campcraft formed the bulk of level 1 subject matter. While these activities can be continued at level 2, there is also opportunity for the inclusion of other pursuits on the understanding that the teaching is being undertaken by suitably qualified personnel. To facilitate and guide the learning in these instances, a set of objectives relating to the individual activities is provided on page 70.





# Teacher Guidelines

## ORIENTEERING

Where orienteering is selected as a minor option, the emphasis will be on providing enjoyable and challenging activities, aimed at consolidating basic orienteering skills and strategies introduced at level 1.

As a major option, orienteering at level 2 aims to build on core skills and strategies by focussing on a limited number of orienteering strategies – distance estimation, use of collecting features and aiming off. It is important at the initial stages to revisit the basic orienteering skills of symbol identification, map setting and thumbing. It is acknowledged that the possibilities for orienteering on many school grounds may be exhausted at this stage and that orienteering may need to be taken off site. The natural setting for orienteering is a forested area. Every effort should be made to provide this context. Thorough reviewing of these skills and strategies with the students is critical to the learning that will take place.

## TEAM CHALLENGES

Whether the course being provided is a major or minor option within the adventure activities element, care must be taken in selecting a range of team challenges to ensure the objectives are achieved. Teachers should also attempt to choose team challenges most appropriate to the students involved and the context in which they are set.

At level 1 the key issues to the implementation of team challenges were safety, planning and team organisation. While these issues continue to be important at level 2, the focus is now on introducing and guiding the review process at the end of the activity phase. This is a crucial part of the lesson, which assists the students in reflecting on their feelings and thoughts concerning their experience. Without this step, students will not retain or transfer what they have learnt. The processing time also serves as lesson closure. To structure this review process the questions in the report card should be discussed in some depth during class and completed by students, possibly as a homework activity.

## CAMPCRAFT

The focus of level 2 campcraft is the planning, safety and care for oneself, the group and the natural environment. It is important that students are aware of the careful preparation and planning necessary for an overnight camp. To promote a more authentic understanding of campcraft, students should use the material in this unit in preparation for an overnight camp on suitable school grounds, at an outdoor education centre, or as part of an expedition on a chosen site. The focus of level 2 campcraft is on the preparation of students for safe and competent campcraft, in consideration of the natural environment in which campcraft occurs and the students' impact on it.

# ORIENTEERING

## MINOR OBJECTIVES

The student will:

- follow recognised orienteering event procedures
- identify the primary safety precautions associated with the sport of orienteering
- increase his / her confidence through continuous map contact — thumbing, setting check-off points.

## MAJOR OBJECTIVES

The student will:

- employ the skill of pace-counting as an accurate method of estimating distance effectively
- plan effective route choices through simplification of route problems
- follow recognised event procedures
- recognise and apply aiming-off, attack points and collecting features as orienteering strategies.

## MENU

SCORE ORIENTEERING  
TRIVIA ORIENTEERING  
DISTANCE ESTIMATION  
PACING



## Unit 1: Score orienteering

### LEARNING OUTCOMES

- The student will :**
- apply a range of orienteering skills and strategies when making route-choice decisions, (attack points, collecting features and handrails)
  - increase his/her confidence through finding controls and encouraging students to use a number of orienteering skills i.e. thumbing, setting, checking-off points
  - be able to fill in a control card correctly
  - experience an enjoyable and challenging activity
  - make decisions on the basis of personal/group strengths and limitations.

- RESOURCES** A copy of the map per student with 10-20 control points identified, control description sheet, control cards per participant. Control + punches if required. Stop clock, whistle, pencil per student.

## SCORE EVENT – EVENT PROCEDURE

A large number of orienteering controls are set out in a designated area. These may be permanently in place. A points value is allocated to each control, with higher marks awarded to controls located on the periphery or in difficult locations. The participant is required to visit as many controls as possible in any order within a specified time limit. The participant may be instructed to punch a control card or to transfer a code or symbol, to confirm his/her presence at the control site. All participants start at the same time — a mass start. Should the time limit be exceeded the participant is penalised (e.g. 5 point deduction for each full or part minute spent over the time limit). A bonus (e.g. 10 points) may be awarded for participants who return on or before the time allowed

### SAMPLE DESCRIPTION/SCORING SHEET

No	Description	Pts. Value
1	Flower bed south end	5
2	Building N.W. corner	5
3	Fence corner	5
4	Evergreen tree	5
5	Middle tree	10
6	Mast	20
7	Hedge end	2

## EXTENSION

The nature of score orienteering is ideally suited to a team element.

Teams of 3 or 4 are challenged to decide on the allocation of controls to team members. Factors such as control difficulty, fitness and time limits become significant. Team management and leadership are required. The task may be made more demanding by reducing the number of maps allowed per team. Two maps for a team of 4 will require decisions on pairing or individual running. It will also promote map memory. Teams may be allowed a map and control card per person or per team.

Each team member can contribute to the team score, therefore this activity is ideally suited to a mixed ability group.

The post-event discussion is an opportunity to highlight effective route choice and navigation together with efficient team management.



Unit 2: Trivia orienteering

**LEARNING  
OUTCOMES**

- The student will:**
- gain confidence through continuous map contact, thumbing, setting and check-off points
  - use a range of navigation skills & strategies, (collecting features, handrails, aiming off)
  - experience an enjoyable activity.

- RESOURCES** A copy of the map with 20-30 control sites identified, a question sheet, pencil per student. Laminated map + questions becomes a permanent resource.

## TRIVIA ORIENTEERING – EVENT PREPARATION

The school grounds or environs need to be explored in order to identify information (trivia) which will act as the subject of questions. These questions will be posed to the students as they participate in the event, for example, the last word on the signpost, number on the pole, colour of the gate, number of steps, who loves Mary?

Devise a Master map of the area, identifying the location of each item on the map. Number each location. Record and retain the information associated with each question in a separate answer sheet.

## EVENT PROCEDURE

This event can be run as a star event or as a typical cross-country orienteering event. The formats of these events have previously been described. As markers are not used in these events navigation is often more difficult. Close and continuous map contact is essential.

The students may be required to answer selected questions or may be asked to follow a prescribed route. A time limit may be usefully employed. The students are required to record the answer to the question corresponding to each location.

### MASTER COPY INFORMATION SHEET

Number	Question	Information
1	Gate No	33
2	Name on the door	Tara
3	Year of manufacture	1959
4	Fence manufacturer	Hayes
5		

### QUESTION SHEET

Information needed	Answer
1 Number on the gate	
2 Name on the door	
3 Year of manufacture	
4 Who manufactured the fence?	
5	

## Unit 3: Distance estimation

### LEARNING OUTCOMES

- The student will:**
- relate distance on the ground to distance on the map in a more accurate way
  - identify a personal pacing scale.

- RESOURCES**
- Distance estimation card, measuring tape (30m), cones
  - Master copies available in appendix.

## TEACHER PREPARATION

Select a suitable area

Identify 3 distances from a starting point using observable features, tape or orienteering controls. These distances should be 100m, 75m, and 50m.

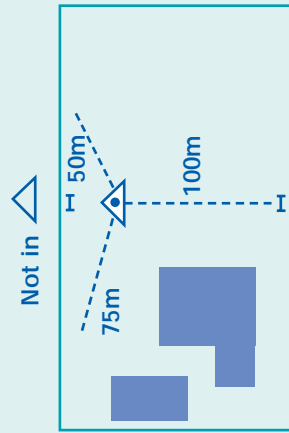

Draw up a distance estimation card and copy for each student.

Names		Distance Estimation	
		Pace Count	
Walking Pace	100m=	75m=	50m=
Running Pace	100m=	75m=	50m=
Estimated Distance			
by eye		pacing	
△ to 1			answer
1 to 2			
2 to △			

## EXERCISE EVENT PROCEDURE

### ESTIMATING BY EYE

Take the group to the starting point. Identify the 3 points on the circuit/course. Outline the importance of good distance estimation in helping to reduce and minimise errors and particularly the risk of over-running controls. The students are required to estimate the distance between control points by eye. They may use the scale on the map as a guide. Ask them to run the various legs of the course before confirming their opinion. Inform them of the correct answer to the various legs.

### CALCULATING PACE COUNT FOR 100M

Measure and make a distance of 100m along a track path or boundary. This should be a straight line distance. Identify the pacing system which is to be adopted - i.e., counting 'double paces' only. Each student walks the 100m and back, counting only when their left leg hits the ground. The number of double-paces for 100m walk is recorded on the distance estimation card. The exercise is repeated at a reasonable running pace. Students should take care to maintain an even pace and not to run beside another student.

Using the course as set out ask the students to estimate their pace count for the 2 other legs. Confirm by walking and running each leg.

## Unit 4: Pacing

### LEARNING OUTCOMES

#### The student will:

- employ pace counting as a means of estimating distance effectively
- be able to accurately transfer the control site to their master map.

### PREPARATION

Select a start point and a series of control locations. Measure the distance from the start to each control site. Prepare a series of maps or cards each one showing a start and one control point. Each student will require a pacing card.

## PROCEDURE

Students complete a control card typical of that associated with an orienteering event. They are also allocated their own grounds/forest map.

## EXTENSION - PACING

Students start at the same time and select a card/map. Having chosen a map they must:

- Copy the control onto their own map
- Check the accuracy of the control point transfer. Teachers should also check.
- Using the scale bar estimate the distance from the starting point to the control site. (Record on pacing card).
- Convert the estimated distance to a personal pace count before setting out. (Record on pacing card).
- Check the accuracy of your estimation of distance by walking the route.
- Having completed the routine in relation to the chosen card, return to base, select another card and continue.
- The teacher gives the actual distances to each control site from the start.

## Pacing Card II

Name .....

	Distance Estimation	Pacing Count	Accuracy
Card A	<input type="text"/>	<input type="text"/>	<input type="text"/>
Card B	<input type="text"/>	<input type="text"/>	<input type="text"/>
Card C	<input type="text"/>	<input type="text"/>	<input type="text"/>
Card D	<input type="text"/>	<input type="text"/>	<input type="text"/>

## Unit 5: Cross-country orienteering

### OBJECTIVES

- To present the sport of orienteering in its complete form in its natural context.
- To encourage students to integrate the various skills and strategies of orienteering in an event format.
- To enable the teacher to assess student proficiency with orienteering skills and strategies.

### RESOURCES

#### Orienteering equipment:

Orienteering controls, punches, control cards, 3 stop watches, planners map, master maps, orienteering map, control description sheets, whistles, start lists, safety pins, clear polythene bags, red pens.

#### Other resources:

Litter bags, rubber bands, first aid, notices (courses on offer, start & finish points), student self assessment sheets.

### EVENT PREPARATION

- Teachers should avail of the skills available in local orienteering clubs or expertise within the staff to assist them in the running of a cross country event. The strategic placing of personnel will help increase confidence and ensure a safe and successful event. Helpers could be placed at critical points on the course to reduce errors and refocus attention on key orienteering skills and strategies.
- Prepare a series of courses - minimum of two, and dependent on numbers participating. Initially, course planning should help promote success by placing controls close to each other and at turning points. Courses should not be overlong, recommended 1 – 2.5km.
- It is necessary to ensure familiarity with the venue and check for any risk that the venue may present. Map changes may need to be recorded.
- Permission may need to be obtained from Coillte or the relevant authority for access to the venues.
- Students must be informed of their obligations in relation to the country code and the event procedure.
- Time may be saved by premarking maps and completing control cards prior to the event.

### ON THE DAY

- Allow time for placing controls.
- A brief walk will familiarise the students with the map and reinforce basic thumbing, setting, feature recognition.
- Prior to participating students should be informed once more of the country code and the event procedure – a cut-off time is useful, e.g. the students must return within 20 - 30 minutes of starting.
- Allocate students to courses. Initially, students may be permitted to participate in pairs. As development, students might then be confident to participate in a second course on their own.
- Students may be started at 30 second / 1 minute intervals.
- Students must record their return and completion of the course – hand in control card.
- Review student learning through discussion and completion of the student self assessment sheet.

### ON THE DAY

- As a concluding activity, the group could be divided in half and set the challenge of collecting the controls. The group returning with the most controls is the winner. Be careful to ensure that students are aware that the first touch of a control will determine ownership. Equipment needs to be protected.

ALL COMPETITORS MUST REPORT TO THE FINISH				FOR OFFICIAL USE ONLY				Mode of transport? please indicate!						
Name		Course		FINISH	START	TIME	TAKEN	FINISH	START	TIME	Other	Relay no.		
Club (Team)		Course		FINISH	START	TIME	TAKEN	FINISH	START	TIME	Other	Course		
Class		Course		FINISH	START	TIME	TAKEN	FINISH	START	TIME	Other	Class		
21	22	23	24	25	26	27	28	29	30					
11	12	13	14	15	16	17	18	19	20					
1	2	3	4	5	6	7	8	9	10					

# TEAM CHALLENGES

## MINOR OBJECTIVES

The students will:

- identify strategies for effective teamwork
- increase their level of agility and physical coordination
- demonstrate an awareness of personal and group safety.
- reflect upon experiences.

## MAJOR OBJECTIVES

The students will:

- develop a positive self-concept through mastery of physical challenges in a supportive atmosphere
- demonstrate their ability to make decisions and will assume responsibility for the outcome of their decisions
- develop team communication through involvement in activities where clarity in giving and receiving instructions is necessary
- reflect upon experiences, review, record and communicate the outcome.

## INTRODUCING TEAM CHALLENGES

When first introducing team challenges it is important to discuss the concept of teamwork. Discuss with students their understanding of the term "teamwork". Encourage the consideration of words such as ;communication, ideas, different roles, leadership, listening, support, trust, etc.

Foster a positive attitude within the group and encourage group members to support each other.

## PLANNING

It is important that students feel a sense of self-reliance as a team if they are to actively set out to solve the problem presented to them. Teacher guidance should be kept to a minimum. Teacher interventions should be made as part of the introduction to the challenge or on request by individual teams. The latter guidance may be provided in the form of "TEAM WORK CARDS".

These cards focus the students' thinking in terms of their understanding of what the task is and how they will approach it.

## SAFETY

Consideration of safety must be an integral part of all planning and performance of team challenges. The activities suggested in this programme have been used safely for many years. There may be safety hazards which are peculiar to specific situations which the teacher must identify and for which she / he must plan.

A safety procedure should be established and implemented which addresses the following matters:

- Equipment
- Group safety
- Personal Safety
- Risks specific to the task.

In setting up the activity identify as many safety concerns as possible.

Ensure that:

- there are sufficient mats and other protective items
- the equipment is appropriate and does not present any inherent dangers
- heights, distances, obstacles and difficulty match the students' capabilities.

A safety ethos must be established from the outset and adhered to at all times. The thoughts of the students must be focussed at all times on their own safety and that of other participants. Personal safety would encompass issues such as individual behaviour, clothing, and footwear. Group safety might relate to matters such as encouraging co operation and use of appropriate language by group members.

A safety ethos must be established from the outset and adhered to at all times. The thoughts of the students must be focussed at all times on their own safety and that of other participants. Personal safety would encompass issues such as individual behaviour, clothing, and footwear. Group safety might relate to matters such as encouraging co operation and use of appropriate language by group members.

All challenges presented take place at a low level. It may occasionally arise that some students will work at a height from which they could fall. Careful "spotting" is essential in such cases. This involves other team members standing, ready to catch another or to cushion a fall. Spotting is best done by adopting a braced position with one foot forward, hands at the ready. Effective spotting is characterised by the taking of appropriate action based on the prompt recognition of a potential danger.

Equipment used for team challenges should be screened to ensure that it does not possess inherent weaknesses or potential hazards, e.g. splinters in planks, wire in torn tyres.

When introducing team challenges it is worthwhile to devote some time to the correct methods of lifting and carrying equipment and to alert the students to the dangers that using such equipment might present, e.g. getting their fingers caught between planks.

## ORGANISING CHALLENGES

Divide the class into groups of 6-10, and ask the group to devise a name for itself. Each group should then be allocated a starting point / work station and given a ;

### CHALLENGE CARD

### TEAM WORK CARD

### STUDENT REPORT CARD

Allow a few minutes for the students to discuss and plan their approach. Establish a time-frame within which the challenge is to be completed.

Students should be encouraged to adopt the following procedure in dealing with team challenges:

- clarify the task
- identify the options and the consequences of each
- agree on a course of action
- implement
- reflect.

## IMPLEMENTATION

At level 1 the key issues in relation to the implementation of team challenges are safety, planning and team organisation. While not a primary focus at this point, the practice of reflection should be initiated and it is suggested that students be encouraged to reflect on their performance in an informal 'question and answer' session. As students become more familiar with the format of team challenges the student report card can provide the structure for the reflective process.

As stated in the teacher guidelines, there is greater opportunity for teacher discretion with regard to choice of activities. In designing a programme a teacher must identify the objectives (minor / major) to be achieved and link them with those of the individual activities as outlined in the teacher guidelines.

Reflection is pivotal to the team challenge experience at level 2. Greater attention should be given to introducing and guiding the review process at the end of the activity phase. This is a crucial part of the lesson, which assists the students in reflecting on their feelings and thoughts concerning their experience. Without this step, students will not retain or transfer what they have learnt. The processing time also serves as lesson closure. To structure this review process the questions in the report card should be discussed in some depth during class and completed by students, possibly as a homework activity. Where appropriate, the team report card can replace the student report card at level 2.

The activities are categorised according to the level of difficulty as follows:

### White (W)

Relatively easy challenges involving little equipment.

### Yellow (Y)

More difficult challenges, requiring more equipment.

### Orange (O)

Complex challenges requiring considerable physical and/or mental effort.

## MENU OF ACTIVITIES

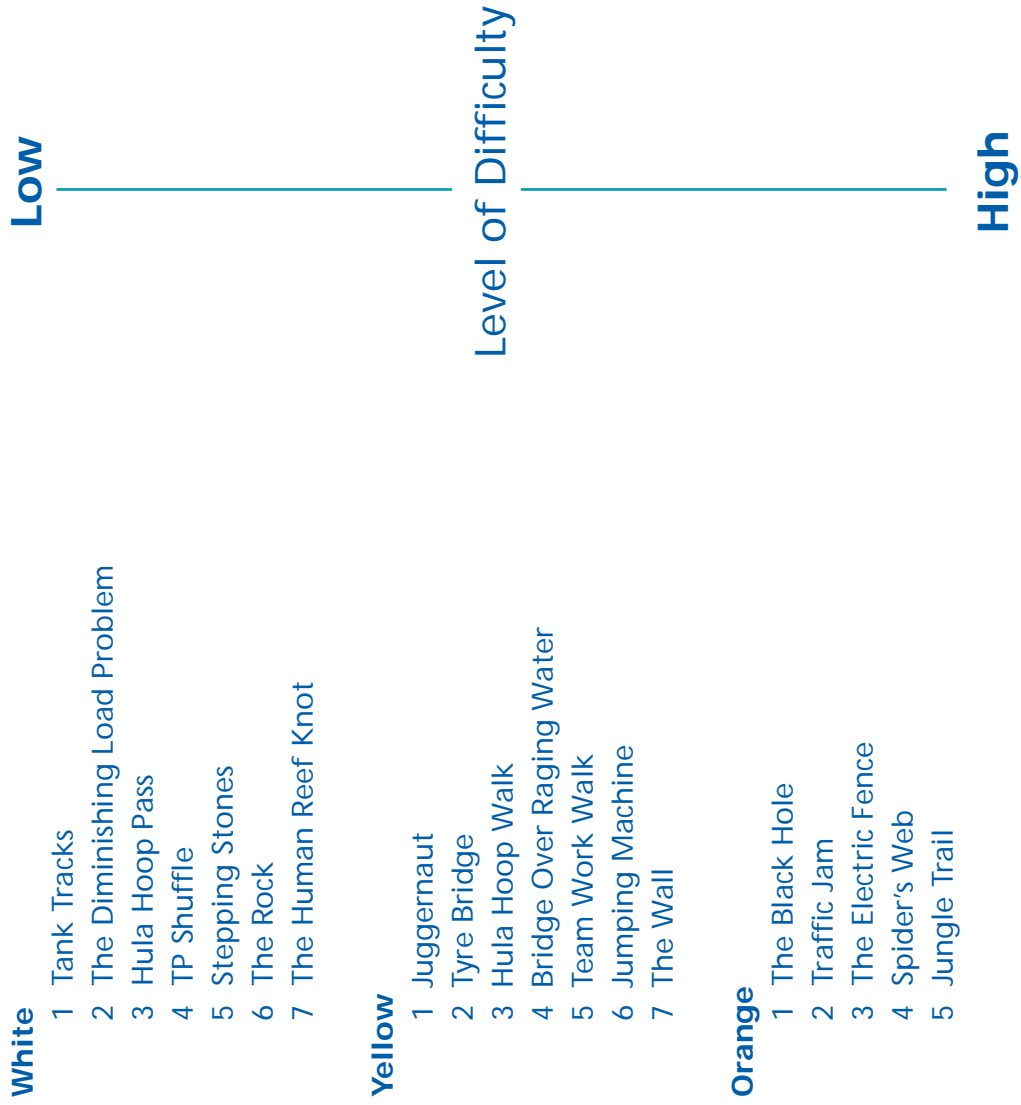

## 1. TANK TRACKS

**OBJECTIVE:** Develops teamwork & communication.

The group (6-8 students) must move over a defined distance without touching the ground, using two mats.

**Equipment:** Gym mats

**Rules:** No member of the group is allowed to touch the ground.

### Procedure

To start, the group stands on one mat with the other above their heads. They must put this mat on the ground, all get on it without touching the ground, pick up the first mat and repeat. This process is repeated until the group have travelled over a certain distance.

**Variations:** Races between the various groups in the class.

**Review:** Teamwork card and discuss outcomes.

## 3. HULA HOOP PASS

**OBJECTIVE:** Develops co-operation and agility.

With the group standing in a circle holding hands, the aim is to pass a hoop around the group as quickly as possible without the circle being broken.

**Equipment:** Large hula hoop.

### Procedure

The group should consist of fifteen to thirty people who stand in a circle with their hands joined. The hoop is placed between two of the participants in the circle on their grasped hands.

**Rules:** The circle of hands cannot be broken

The hoop should start and finish with the same two people.

**Variations:** The hoop can be made smaller or an inner tube can be used to increase the challenge.

**Review:** Teamwork card and discuss outcomes.

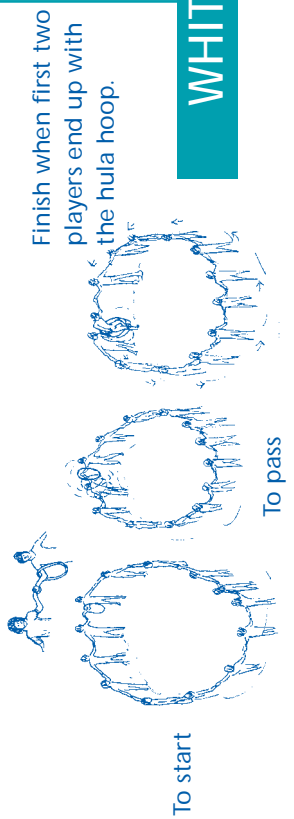

## 2. THE DIMINISHING LOAD PROBLEM

**OBJECTIVE:** Develops group co-operation and problem solving.

The aim of this activity is to move a group or series of groups (teams) across an open field as quickly as possible. The distance can vary with the estimated strength of the groups.

### Rules

- To cross the open area a person must be carried.
- The carrier must return and be carried him / herself.
- The only person allowed to walk / run across the open area is the last person.
- If the carried person touched the ground while being transported both members must return to the start.
- The number of people being carried and carrying can vary with the strength and / or imagination of the group i.e. one-to-one is not the only way.

### Variations

The aim of the activity can be changed to move the entire group across the distance in as few trips as possible.

**Safety:** The usual safety precautions with regard to lifting and carrying apply. Care must also be taken to ensure that students who are self-conscious about size are not put into a situation which might cause them some embarrassment.

**Review:** Teamwork card and discuss outcomes.

## 4. THE TP SHUFFLE

**OBJECTIVE:** Develops problem solving skills.

Two groups of ten people line up / balance on opposite ends of the TP so that the two groups are facing one another in single file

### Equipment

A 10m telephone pole laid down on a grassy area. Ensure that the pole is stationary.

### Rules

- The two groups have to exchange ends without touching the ground.
- Time the entire procedure and assign a 15 second time penalty for every touch with the ground.
- It is important with a timed initiative problem to attempt the activity more than once. The first attempt establishes a time to beat.

**Review:** Teamwork card and discuss outcomes.

WHITE (W)



## 5. STEPPING STONES

**OBJECTIVE:** Develops problem solving skills, co-operation and communication.

For this activity, the team stands in a specific order, using bases set in a straight line and then reverse the order by moving from base to base

### Equipment

One base is required for each member of the team plus one extra base. Ensure that bases are made of non-slip material. If none are available, tape 300mm-375mm squares on the floor or use carpet squares cut to that size.

### Procedure

The team have successfully completed the challenge when the members are standing in reverse order from their starting positions.

For example:

**Starting position:**

Paul Ann Maura Jim Liz John Donal Theresa

**Ending position:**

Theresa Donal John Liz Jim Maura Ann Paul

### Rules

- Only one student may touch a base at a time.
- When moving from one base to another, one may move in either direction to the next base.
- Team members may only move to a new base if it is empty.
- The bases may not be moved.
- No one may touch the floor with any part of their body.
- If a rule is broken the team must start over again.

**Review:** Teamwork card and discuss outcomes.

## 6. THE ROCK

**OBJECTIVE:** Develops team work, problem solving, awareness of group safety, communication

In groups of 6 to 8, all group members must balance on the rock (or be off the floor) for a slow count of one to five.

**EQUIPMENT:** A rock i.e., 325mm automobile tyre (if it is a large group such as 10 members a 350/375mm tyre may be required) or a heavy-duty box. Several mats to be placed underneath/around the rock.

**Rules:** No one may touch the ground for a specified duration.

**Review:** Teamwork card and discuss outcomes.

## 7. THE HUMAN REEF KNOT

**OBJECTIVE:** Develops communication, teamwork, decision-making and problem solving.

The challenge is to form a reef knot with the rope, while all members of the team hold onto the rope.

**Equipment:** One long rope

1. Begin with an over and under crossing (A).
2. Bring the ends back above in a second similar crossing (B).
3. The completed knot is tightened by pulling on the ends (C).



**Procedure:** The teacher / group leader demonstrates how to tie a reef knot with the rope. Upon completion of this exercise all members of the team take up position along the length of the rope and hold on to it. With all members holding on to the rope, the team must form a human reef knot.

### Rules

- All team members must hold onto the rope.
- If any member of the team loses their grip, the team must start over.
- The reef knot is the only kind of knot that can be accepted.

**Review:** Teamwork card and discuss outcomes.

## 1. JUGGERNAUT

**OBJECTIVE:** Develops problem solving, safety awareness, team work and decision making.

The group ( 6 – 10 is appropriate ) must transport themselves and their equipment across an area allowing only the tyres to touch the ground.

### Equipment

- 3 tyres
- 2 planks - scaffold planks are suitable

### Rules

- No one may touch the ground
- Planks may not touch the ground
- If any infringement occurs, the group must return to the start.

### Safety

Students need to be particularly safety-conscious when involved in this challenge. A number of solutions is possible in this challenge. However, solutions which involve the tyres being used on their side as rollers is not allowed. Fingers may be trapped between the tyre and a plank. Excessive plank overhang should also be avoided.

Crates or other suitable equipment may be substituted for the tyres.

**Review:** Teamwork card and discuss outcomes.

## 2. THE TYRE BRIDGE

**OBJECTIVE:** Develops teamwork, communication and balance.

The group moves over a defined distance (the river), without touching the ground, using tyres to construct a moving bridge.

**Equipment:** One tyre (small) per group member plus one additional tyre. A defined area - the length of a basketball court is suitable.

### Procedure

Place tyres near the starting position. Ensure that there is space near the end line so that the tyres can be stacked safely. As the students step on the tyres and form a line with the tyres, the team members pass the last tyre to the front of the line, and, one by one, each member steps forward.

Some teams choose to carefully lay the tyres on the floor ahead - others may toss the tyres forward.

### Rules

- The students must begin standing on land.
- Only one person may be on a tyre at a time.
- If a team member touches the river (the floor) with any part of the body, the team must return to the starting position.

**Review:** Teamwork card and discuss outcomes.

### 3. WALK A HOOP

**OBJECTIVE:** Develops team work, co-ordination and communication.

The group (6 people) must walk across a defined area without dropping either hoop.

#### Equipment

Two hula hoops per team.

#### Procedure

A team consists of six people which is divided into three sub-groups. The group at the centre places their left leg inside one hula hoop, and right leg inside a second hula hoop. The side groups then connect to the opposite sides of the hula hoops. At this point there should be two people on the line, with right leg inside a hoop, which has the left leg inside a hoop, which has the right leg of the centre group through it. The teacher then raises both hoops to knee height, instructing the group to put tension appropriate to hold it above the ground.

The task is then for the groups to walk across the assigned space without dropping either hoop

#### Rules

- The leg is the only part of the body which can keep the hoop in place
- If the group drops the hoop, they must return to the starting line and start over.

**Review:** Teamwork card and discuss outcomes.



Walk A Hoop

### 4. BRIDGE OVER RAGING WATER

**OBJECTIVE:** Develops problem solving, team work, communication and decision making.

The team challenge is for all group members to travel from one end of a space (land) to the other end without touching the floor (river). The length of a basketball court is suitable. A time limit can be imposed and success can be based on criteria other than crossing the river if necessary.

#### Equipment

- Four automobile tyres
- Two planks (2.44m x 100mm x 50mm)
- Two ropes (3m/5m lengths of sash cord work best)

#### Rules

- Groups members may not touch the ground (river)
- The group must carry all the equipment to the other side
- A group member may not step on a plank if it has one end in a river
- If a rule is broken, the group must return to the starting point.

#### Variations

- Obstacles can be placed in the rivers that the group must travel around, over or under
- The group can be asked to carry some object across the river.
- Teams can be penalised by removing, for further use, the item of equipment that touches the ground.

**Review:** Teamwork card and discuss outcomes.



## 5. TEAMWORK WALK

**OBJECTIVE:** Develops team work, range of roles within the group, communication, problem solving, persistence, positive self concept. The challenge for the team to walk over a defined distance using planks of wood without any part of their bodies touching the ground

### Equipment

Per team — 2 walking boards (2.44m x 100mm x 50mm) with ropes attached at one foot intervals.

### Set Up

The team stand behind the starting line with the walking boards side by side. Each member of the team stands with one foot on each board. The students at the front and back, hold a rope in each hand which is attached to the board.

### Possible solutions

A group leader or organiser is useful for this challenge to co-ordinate the team's movements. To move a board forward, members of the team must place their weight onto one board, while lifting the other and bringing it forward with the aid of the ropes. The team then transfer their weight on to the other board and the same procedure is applied.

### Variations

- The challenge must be completed within a time limit.
- Use both a time limit and a distance goal. How far can a group travel in a given time.
- Devise an obstacle course or zig-zag path.
- Set a number of objects along the path to be picked up, e.g. a ball, hoop, or cone.
- Send the group members under a lowered parallel bar or a volleyball net while walking.

**Review:** Teamwork card and discuss outcomes.

## 6. JUMPING MACHINE

**OBJECTIVE:** Develops team work, communication, agility, physical coordination and decision making.

In this activity, the group must complete ten consecutive jumps without a miss or without stopping the rope between jumps.

### Equipment

One tug-o-war rope or suitable alternative.

### Set Up

To master this challenge, a group must devise a plan for entering the turning rope and may also need to have some group members practice turning the heavy rope. Because of its weight and length, the rope will need a high arc.

The team selects two of its members to turn the tug-o-war rope, as described. Other team members attempt to jump the rope ten consecutive times. The entire group (minus the turners) must jump the rope at the same time. The rope turners may change places with a jumper if he/she needs to rest.

### Rules

- There may be only one team member at each end of the rope. All other group members are jumpers.
- To be counted, the jumps must be consecutive.
- The rope must pass over the jumper's heads and below their feet.
- If they miss, jumpers must begin the task again.
- Turners do not have to hold the very end of the tug-o-war rope.

### Possible Solutions

There are two main solutions. The first requires the jumpers to stand in a straight line, close together (one to two feet apart). On a signal, all jumpers start jumping at the same time. The second solution has jumpers start jumping rope one or two at a time. With this approach, the group does not start counting jumps until all team members have entered the turning rope.

**Review:** Teamwork card and discuss outcomes.

# TEACHER GUIDELINES

## 1. THE BLACK HOLE

**OBJECTIVE:** Develops team work, awareness of group safety, communication, trust, decision making and co-ordination. The challenge is to get all team members from "outer space" through the black hole (the hoop), to the "earth" side.

**Equipment**

- 2 volleyball stands well secured.
- 1 hula hoop.
- Rope to suspend the hoop between the standards.
- Sufficient mats to cover the ground directly underneath and around the hoop.

**Set Up**

See diagram below.

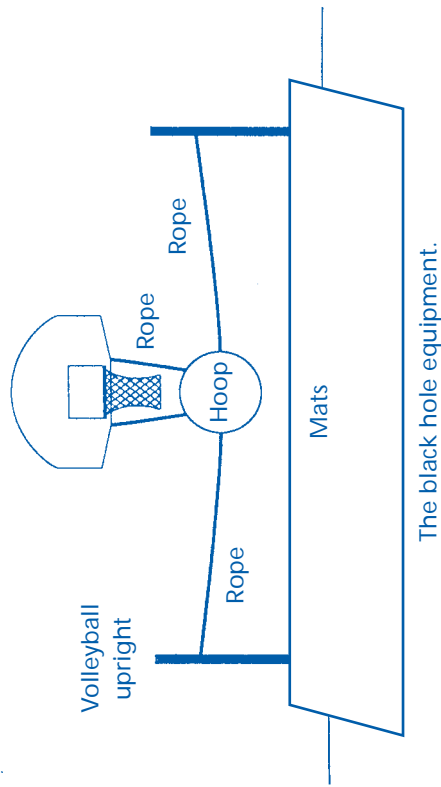

The hoop height should be set so that the bottom of the hoop is about waist height on the majority of the students involved. A tape line may be used to help divide the working area into two distinct spaces.

**Rules**

- All team members must go through the "Black Hole".
- No person may touch the "Black Hole" (hoop).
- No one may dive through the hoop.
- Group members must remain on mats during the challenge.
- If any rule is broken, the person making the mistake and one person who has passed through the hoop must start again.

**Review:** Teamwork card and discuss outcomes.

# TEACHER GUIDELINES

## 2. TRAFFIC JAM

**OBJECTIVE:** Develops problem solving, role allocation (leader/follower — recognition of the value of each), communication and persistence.

In this activity the participants who are divided into 2 groups of at least 4, exchange places on a line of squares that has one more place than the number of people in both groups.

### Set Up

The squares can be defined by chalk, masking tape or scrap paper and must be laid down in a straight line, ensuring that there is one more place than the total number of participants. The squares should be an easy step from each other.



### Procedure

One group stands on the places to the left of the middle square. The other group stand to the right. Both groups face the middle unoccupied square. Using the moves outlined below, the participants on the left side must end up on the places on the right side, and vice versa.

### Rules

- A participant may only move forward.
- A participant may move forward one space into an empty space.
- A participant may move forward around one person into an empty space.

Thus

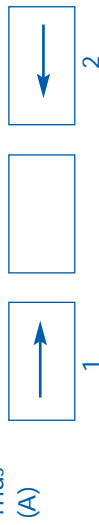

Here either 1 or 2 may move into the space

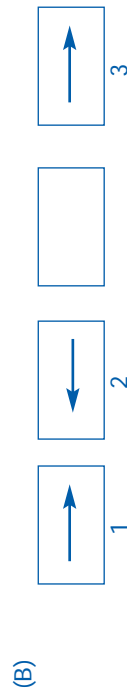

Here 1 may move into the empty space

- Only one person moves at a time.
- Only one person may be on a square at a time.
- A participant may walk on the ground to get from one square to another. The problem is not staying off the ground while moving from square to square, but the sequence in which people move.

As the group succeed in completing the task it may be discovered that one person giving the commands is the most effective way of solving the 'traffic jam'. Ask the group to repeat the task a number of times. A leader should emerge who gives instruction, while the others follow his / her directions.

**Review:** Teamwork card and discuss outcomes.

# TEACHER GUIDELINES

## SOLUTION

Starting order of team



The solution to this challenge is so specific, you may wish to practice using cards as shown above. The notes are outlined below.

- Step 1 D moves forward to empty base.
- Step 2 1 moves around D to empty base.
- Step 3 2 moves forward to empty base.
- Step 4 D moves around 2 to open base.
- Step 5 C moves around 1.
- Step 6 B moves forward to open base.
- Step 7 1 moves around B.
- Step 8 2 moves around C.
- Step 9 3 moves around D.
- Step 10 4 moves forward to open base.
- Step 11 D moves around 4 (D completes switch).
- Step 12 C moves around 3.
- Step 13 B moves around 2.
- Step 14 A moves around 1.
- Step 15 1 moves forward (1 finishes).
- Step 16 2 moves around A (2 finishes).
- Step 17 3 moves around B.
- Step 18 4 moves around C.
- Step 19 C moves forward (C finishes).
- Step 20 B moves around 4 (B finishes).
- Step 21 A moves around 3.
- Step 22 3 moves forward (3 finishes).
- Step 23 4 moves around A (4 finishes).
- Step 24 A moves forward (the task is complete).

### 3. ELECTRIC FENCE

**OBJECTIVE:** Develops safety awareness, communication, decision making and trust.

The challenge is to get all members over the fence without touching any part of it.

**Equipment:**

Fence: a rope extended between 2 trees no more than 2 metres above the ground. Indoor alternatives possible with volleyball poles, well secured.

Several mats to be placed underneath / around the fence.

**Rules**

- Everyone must be involved in assisting the person going over the fence.
- No part of any person may touch the fence.

**Review:** Teamwork card and discuss outcomes.

### 4. SPIDER'S WEB

**OBJECTIVE:** Develops teamwork, co-operation, communication, decision-making, trust and awareness of group safety.

The challenge is to pass each group member through a web opening, without touching the web with any part of the body.

**Equipment:**

2 volleyball stands, well secured or 2 trees a suitable distance apart (3 – 5m apart)

**Set-up**

See diagram below.

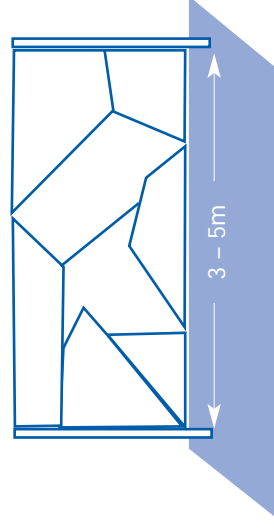

The height and size of web openings should be constructed with consideration of the height and size of the students involved.

**Rules**

- All team members must go through a web opening.
- Once an opening is used, that opening may not be used for further passage.
- No person may touch the web with any part of the body.
- If a student touches the web that student comes back to the beginning side.
- All group members must actively spot each other.
- Team members may be wheelbarrowed safely through a bottom hole.
- Before any team member is lifted through the web, there must be at least three students on the other side to lift that person through and they themselves must have gone through the web.

**Variations**

- If someone touches the web, the whole group starts over.
- If there are more team members than spaces, one or two passages can be chosen for two group members to pass through, but once chosen, cannot be changed.
- Do the challenge silently.
- Hand out every group member a picture of a body part; whatever body part they receive, they lose the use of that same body part.

**Review:** Teamwork card and discuss outcomes.



## TEACHER GUIDELINES

### 5. JUNGLE TRAIL

**OBJECTIVE:** This can be the culminating challenge to a series of lessons devoted to team challenges or can be used as a means of introducing a variety of challenges to a class while ensuring full participation.

The activities to be included are at the discretion of the teacher – those outlined below are simply included for the purpose of explanation. The safety precautions and success criteria relevant to the individual challenges apply to this activity. To ensure the smooth running of the “Jungle Trail”, it is important to establish a time limit (based on the students’ capabilities) within which the individual challenges must be completed.

**Equipment:**

As dictated by selection of team challenges.

**Set-up:**

Given the time involved, it is worthwhile to undertake this activity with all class groups doing the team challenge option.

**Safety:**

- Students must be made aware of the safety precautions relevant to the individual challenges.
- Only activities which are of low to medium difficulty / white and yellow categories – (see menu of activities) are suitable for inclusion in the Jungle Trail.

**Rules**

- The rules applicable to the individual team challenges remain in place.
- Each team starts at a different challenge.
- Each team starts their challenge on the signal, and when the time is up they must return the equipment to its original position and move on to the next challenge.
- All teams must move around the circuit in the same direction.

**Review:** Teamwork card and discuss outcomes.

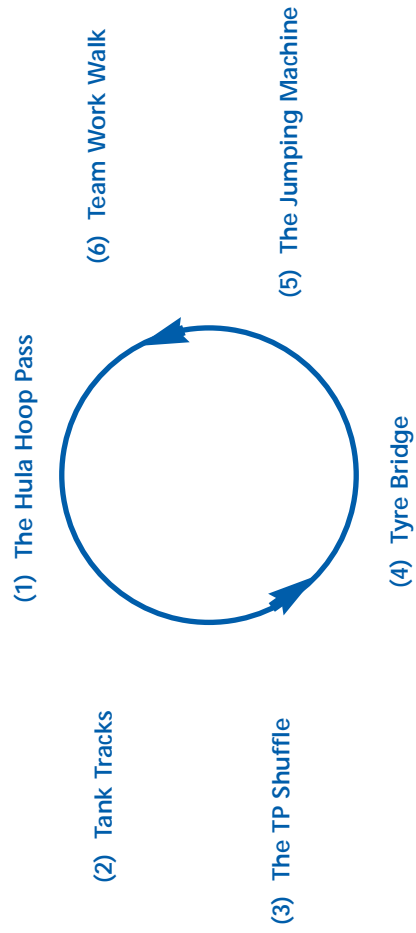

ORANGE (0)

## CHALLENGE CARDS

### 1. Tank Tracks

**EQUIPMENT PROVIDED**  
2 gymnastics mats

**STARTING POSITION**  
Group stand on one mat at the starting line, with the other above their heads.

**OUR CHALLENGE**  
The task is to move across the area indicated without any member of the team touching the ground.

**RULES**

- No team member can touch the ground.
- If a team member touched the ground the team must return to the start and begin again.

### 2. The Diminishing Load Problem

**STARTING POSITION**  
All members of the group stand at one end of a field / open space.

**OUR CHALLENGE**  
The task is to move all of the team across the space as quickly as possible.

**RULES**

- To cross the open area a person must be carried.
- The carrier must return and be carried him/ herself.
- The only person allow to walk/ run across the open area is the last person.
- If the carried person touches the ground while being transported, both members must return to the start.
- The number of people being carried and carrying can vary with the strength and/ or imagination of the group i.e., one-to -one is not the only way.

### 3. Hula Hoop Pass

**EQUIPMENT**

One large hula hoop.

**STARTING POSITION**

The group (15 to 30 people), stand in a circle with their hands joined. The hoop is between two people on their grasped hands.

**OUR CHALLENGE**

The task is to pass the hoop around the circle as quickly as possible without the circle being broken.

**RULES**

- The circle cannot be broken
- The hoop should start and finish with the same two people.

### 4. The TP Shuffle

**EQUIPMENT**

10m telephone pole

**STARTING POSITION**

The team is divided into two groups line up/ balance on opposite ends of the TP so that the two groups are facing one another in single file.

**OUR CHALLENGE**

The two groups have to exchange ends.

**RULES**

- No member of the team may touch the ground.
- The task is timed and a 15 second penalty is assigned for every touch of the ground.
- This activity should be repeated more than once. Can our team beat the first attempt ?

## 5. Stepping Stones

### EQUIPMENT

One base for each group member and one extra base.

### STARTING POSITION

Team members stand on one base each, leaving an unoccupied base at the end of the line.

### OUR CHALLENGE

The task is completed when the team is standing in the reverse order to its starting position

Example

Starting position: 1 2 3 4 5 6 7 8

Ending position: 8 7 6 5 4 3 2 1

### RULES

- Only one person may touch a base at a time
- A person may move in either direction to a neighbouring base
- One can only go into a new base if it is empty
- The bases may not be moved
- If anyone touches the floor, the group must start over
- If more than one person touches a base, the group must start over.

## 6. The Rock

### EQUIPMENT

Several mats.

One tyre or box ("The Rock").

### STARTING POSITION

Group members stand next to the tyre or box.

### OUR CHALLENGE

The task is completed when all group members are balanced on the rock (off the floor) for a slow count of one to five.

### RULES

- All group members must be off the floor.
- Group members do not have to be touching the rock.

## 7. The Human Reef Knot

### EQUIPMENT

A long rope

### STARTING POSITION

All team members take position along the length of the rope and hold on to it.

### OUR CHALLENGE

The challenge is to form a reef knot with the length of rope without any member losing their grip of the rope. The task must be completed within the time specified by the teacher.

1. Begin with an over and under crossing (A).
2. Bring the ends back above in a second similar crossing (B).
3. The completed knot is tightened by pulling on the ends (C).

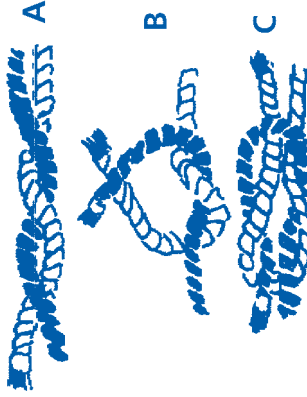

### RULES

- All team members must hold onto the rope.
- If any member of the team loses their grip, the team must start over.
- The reef knot is the only kind of knot that can be accepted.

WHITE (W)

## CHALLENGE CARDS

### 1. Juggernaut

#### EQUIPMENT

- 3 tyres
- 2 planks

#### STARTING POSITION

All members of the group stand on the starting line with their equipment.

#### OUR CHALLENGE

The team is to cross the area ( defined by the teacher ) allowing only the tyres to touch the ground.

#### RULES

- No member of the group is allowed to touch the ground.
- Planks may not touch the ground.
- If any infringement occurs, the group must return to the start.

#### SAFETY

A number of solutions is possible in this challenge. However solutions which involve the tyres being used on their side as rollers is not allowed. Excessive plank overhang should also be avoided.

### 2. The Tyre Bridge

#### EQUIPMENT

One tyre for each member of the group, plus one extra tyre.

#### STARTING POSITION

Group on one side of the river with stack of tyres.

#### OUR CHALLENGE

The task is completed when the tyre bridge has been used to move the group from one side of the river to the other (the area defined). The group must be on land with the tyres stacked vertically.

#### RULES

- Only one person on a tyre at a time.
- If anyone touches the river with any part of their body, the bridge must return to the starting position.
- If two people stand on a tyre at one time, the bridge must return to the starting position.

## CHALLENGE CARDS

### 3. Hula Hoop Walk

**EQUIPMENT**  
Two hula hoops.

**STARTING POSITION**

The team of six people divide themselves into pairs. The pair at the centre stand with their left leg inside one hula hoop and their right leg inside a second hula hoop. The other pairs then connect to the opposite sides of the hula hoops. The teacher then raises both hoops to knee height. The team puts appropriate tension on the hoops to hold them above the ground.

**OUR CHALLENGE**

The task is for the team to walk across the assigned space without dropping either hoop.

**RULES**

- The leg is the only part of the body which can keep the hoop in place.
- If the hoop drops to the ground, the team must return to the starting line and start over.

### 4. Bridge Over Raging Water

**EQUIPMENT**  
4 tyres.  
2 lengths of sash cord.  
2 planks (2.44m x 100mm x 50mm)

**STARTING POSITION**

All group members start at one end of the river with their equipment.

**OUR CHALLENGE**

The task is completed when all group members have crossed the river without touching the floor. All equipment must be brought to the end by the group.

**RULES**

- Group members may not touch the river (floor).
- Group members may not stand on a board if either end of it is in the river.
- If a rule is broke, the group must return to starting position with all the equipment and start again.

**Safety issue - beware of getting fingers caught under the planks of wood.**

## CHALLENGE CARDS

### 5. Teamwork Walk

#### EQUIPMENT

2 planks of wood with a rope attached to each end.

#### STARTING POSITION

The planks of wood are placed side by side. The team members place one foot on each plank and the persons at the front and back hold a rope in each hand.

#### OUR CHALLENGE

The task is completed when the team have completed the course without anyone touching the floor, a wall, or any other object with any part of their bodies.

#### RULES

- All group members must have their feet on the planks.
- No one may touch the floor, wall or any other object.
- Group members must travel the designated path from start to finish.
- If any of the rules are broken, the group must start over.

### 6. Jumping Machine

#### EQUIPMENT

Tug-o-war rope. Heavy rope.

#### STARTING POSITION

All team members stand next to the tug-o-war rope as it lies on the floor.

#### OUR CHALLENGE

The challenge is for the team to complete 10 consecutive jumps without a miss.

All jumpers must jump at the same time.

#### RULES

- There may be only one group member at each end of the rope. All others must jump.
- The 10 jumps must be consecutive. If there is a miss, the task begins again.
- The rope must be turned so that it goes over the heads and below the feet of group members.
- Counting does not begin until all jumpers are jumping.

YELLOW (Y)



## CHALLENGE CARDS

### 1. The Black Hole

#### EQUIPMENT

- 2 volleyball stands - well secured.
- 1 hula hoop.
- Rope to suspend the hoop between the standards.
- Sufficient mats to cover the ground directly underneath and around the hoop.

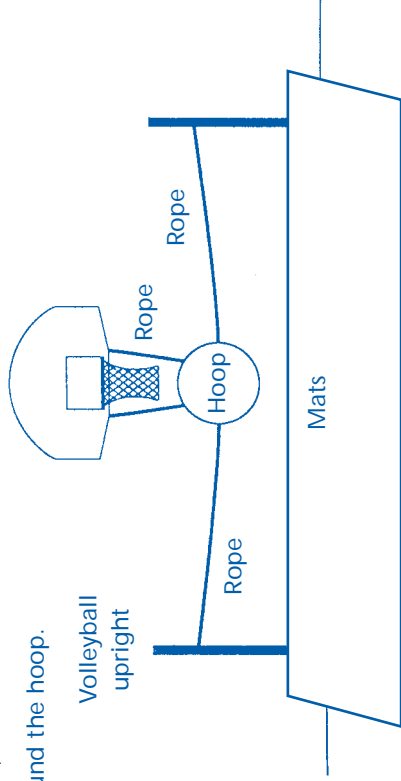

#### STARTING POSITION

See diagram opposite.

The hoop height should be set so that the bottom of the hoop is about waist height on the majority of the students involved. A tape line may be used to help divide the working area into two distinct spaces.

#### OUR CHALLENGE

The challenge is to get all team members from "outer space" through the black hole (the hoop), to the "Earth" side.

#### RULES

- All team members must go through the "Black Hole".
- No person may touch the "Black Hole" (hoop).
- No one may dive through the hoop.
- Group members must remain on tumbling mats during the challenge.
- If any rule is broken, the person making the mistake and one person who has passed through the hoop must start again.

ORANGE (O)

## CHALLENGE CARDS

### 2. Traffic Jam

#### EQUIPMENT

- 9 squares defined by:
  - chalk
  - masking tape
  - cardboard squares.

#### STARTING POSITION

The team is divided into two groups of four each who stands a square. The square in the centre is free and both groups face the middle, unoccupied square.



#### OUR CHALLENGE

The task is for the groups to exchange places

#### RULES

- A participant may only move forward.
- A participant may move forward one space into an empty space.
- A participant may move forward around one person into an empty space.

Thus

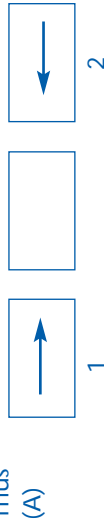

Here either 1 or 2 may move into the space

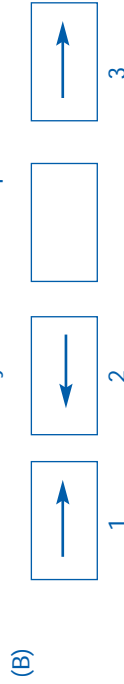

Here 1 may move into the empty space

- Only one person moves at a time.
- Only one person may be on a square at a time.
- A participant may walk on the ground to get from one square to another. The problem is not staying off the ground while moving from square to square, but the sequence in which people move. As the group succeed in completing the task it may be discovered that one person giving the commands is the most effective way of solving the 'traffic jam'. Ask the group to repeat the task a number of times. A leader should emerge who gives instruction, while the others follow his / her directions.

**ORANGE (O)**

## CHALLENGE CARDS

### 3. Electric Fence

**EQUIPMENT**

Rope - to be extended between two points not higher than the tallest group member above the floor / ground, Mats.  
2 volleyball poles, well secured.

**STARTING POSITION**

The team stand on one side of the fence.

**OUR CHALLENGE**

All team members must get over the fence.

**RULES**

- No team member may touch the fence.
- If the fence is touched all of the team must return to the starting side.
- Everyone must be involved in spotting and assisting the person going over the fence.

### 4. Spider's Web

**EQUIPMENT**

- 2 volleyball stands, well secured or 2 trees a suitable distance apart (3 – 5m apart).
- A pre-fabricated web (made up of 8 / 10 open web sections) constructed from a variety of small ropes or bungee cord.
- Sufficient mats to cover the ground directly underneath and around the web.

**STARTING POSITION**

See diagram – all team members must start on the same side.

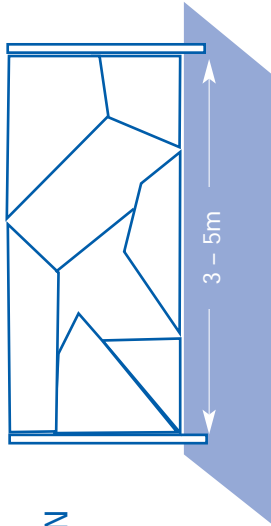

**OUR CHALLENGE**

The challenge is to pass each group member through a web opening, without touching the web with any part of the body.

**RULES**

- All team members must go through a web opening.
- Once an opening is used, that opening may not be used for further passage.
- No person may touch the web with any part of the body.
- If a student touches the web that student comes back to the beginning side.
- All group members must actively spot each other.
- Team members may be wheelbarrowed safely through a bottom hole.
- Before any team member is lifted through the web, there must be at least three students on the other side to lift that person through and they themselves must have gone through the web.

## CHALLENGE CARDS

### 5. Jungle Trail

#### STARTING POSITION

Each team is assigned a separate challenge at which they start.

#### OUR CHALLENGE

The challenge is to complete all of the tasks on the trail and return to the original starting position. The individual tasks must be completed within the time specified by the teacher.

#### RULES

- All team members must complete the trail.
- The tasks must be completed within the time specified by the teacher.
- The rules which apply to the individual tasks must be adhered to, by all group members.

ORANGE (0)

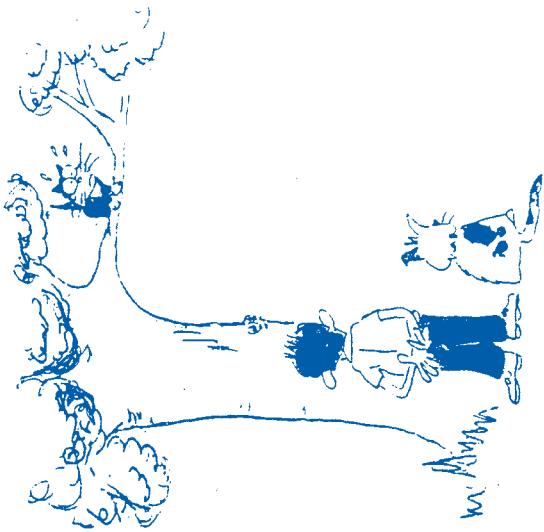

1. **What is the challenge?**

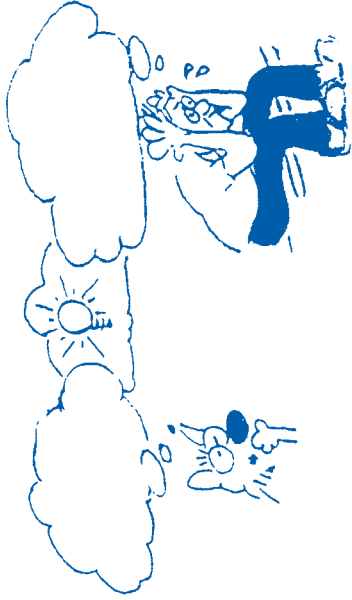

2. **How many different ways**

**can we solve this challenge?**



5. **Let's do it!**

3. **What is the best way and the safest way for us?**

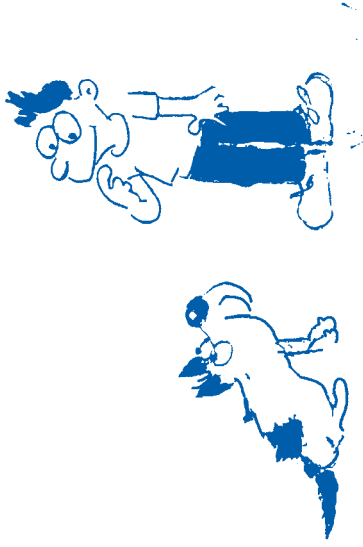

4. **Who's doing what?**

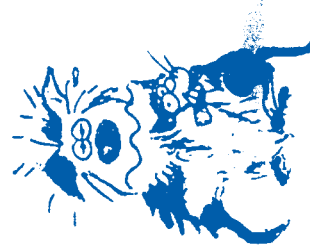

6. **How did it go?**

Complete team and student report cards.

1. What was your job as a team member in solving the challenge?

.....

.....

.....

.....

.....

.....

.....

.....

.....

.....

3. Describe any places you became stuck and how you became unstuck when solving the challenge.

.....

.....

.....

.....

.....

.....

.....

.....

.....

.....

2. What safety precautions did you take?

.....

.....

.....

.....

.....

.....

.....

.....

.....

.....

4. Write a note of advice to a student in the next class who is going to undertake this team challenge.

.....

.....

.....

.....

.....

.....

.....

.....

.....

.....

SIGNATURE .....



## CAMP CRAFT

### MINOR OBJECTIVES

The student will:

- outline and demonstrate consideration for safe camping practices
- identify appropriate clothing and equipment for personal comfort and hygiene
- demonstrate an ability to create additional camping resources.

### MAJOR OBJECTIVES

The student will:

- demonstrate care for and safe use of camping and personal equipment
- be aware of group and personal equipment necessary for campcraft
- observe good safety practices in accordance with the country code
- have an awareness of the insulation properties of various types of clothing, sleeping bags, ground mats and other camping equipment
- establish an effective camp layout regarding hygiene and storage.

### MENU

#### PERSONAL EQUIPMENT

- Appropriate summer/winter clothing
- Importance of insulation:
  - tent
  - ground mat
  - sleeping bag
- Creating a form of ground insulation
- Packing your outdoor kit

#### LOCATION OF YOUR CAMPSITE

- Safety points for camp location
- Students draw sketch map of suitable location
- Choose a suitable location in local area/school grounds

#### EXTRA CAMPING RESOURCES

- Creating a clothes line
- Positioning of equipment at the campsite e.g. tent direction, campfire placing
- Building a shelter

#### SAFETY / COUNTRY CODE

- Develop knowledge of the country code through practical application e.g. school litter control
- Safety on the campsite regarding campfires, animals and location



## TEACHER GUIDELINES

The following options have been provided as methods of applying the campcraft unit.

### OPTION 1

1. The class is divided into groups, each group being assigned:

- a map of the school grounds with route, identifying the location of task cards
- a rucksack

- a range of equipment including: - clothing - food and drink - materials for building a shelter.

2. The groups follow the map and on locating the task card, they must complete the exercise, e.g. creating a shelter, and then move on to the next location.

3. The teacher must specify the time in which the activity is to be completed.

4. At the end of the lesson, all groups gather together and review their programme..

### OPTION 2

Elements of campcraft can be included in a team challenge circuit as a minor option.

### OPTION 3

Campcraft material can be used as preparation for a night camp on the school grounds or at an outdoor education centre. This provides a focus, through the preparation, of a realistic campcraft situation. It also helps to create momentum for the outdoor experience.



### Packing your Rucksack

A loaded rucksack must be well-balanced.  
 Articles needed during the journey should be on the top or in the side pockets of your pack i.e., food for the day, first aid.  
 Do not have articles dangling from your pack.  
 All clothing and sleeping bag should be kept in a polythene bags.

#### PACKING YOUR RUCKSACK

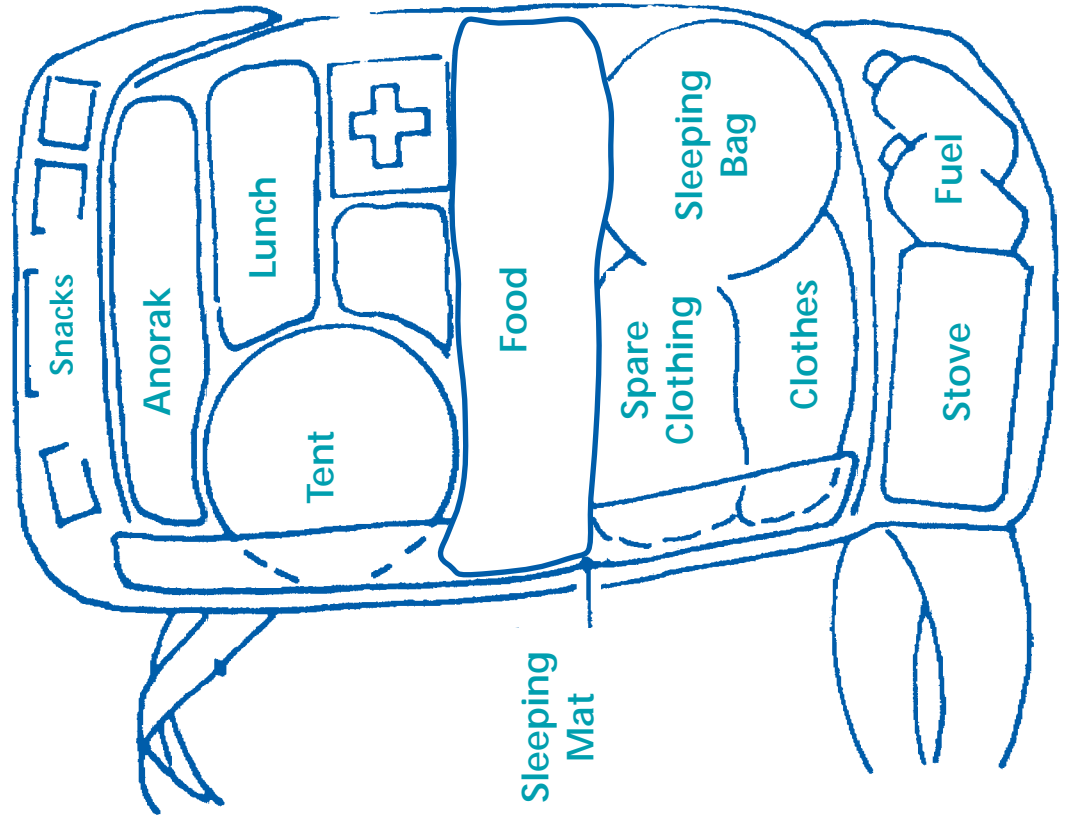

#### Card 1

**PACK A  
 RUCKSACK FOR  
 AN OVERNIGHT  
 CAMP IN MID-  
 SUMMER**

#### Card 1

**CHECKLIST  
 PACKING A  
 RUCKSACK**

- Is the rucksack waterproofed?
- Are emergency supplies e.g. first aid kit, wet gear, easy to access?
- Is the rucksack comfortable to carry?

## Choosing a campsite

### An ideal campsite:

The tent is sheltered by trees from prevailing winds, yet is not so close as to be endangered by falling branches. It should be close to a water supply but not on low ground close to a river or stream as it may be vulnerable to flooding

### CHOOSING YOUR CAMPSITE AND POSITIONING YOUR EQUIPMENT SAFELY

Hang food from tree away from animals

Do not erect your tent under a tree as branches could snap off in high winds

Prevailing wind

Flat ground

Keep your tent entrance facing away from the wind

Make sure sparks from the fire cannot reach your tent

Rocks

Level ground

Water and food can also be kept cool in a nearby river/stream

Hang boots upside down to air and dry out and to deter animals from climbing inside

Keep food cool and covered under the shade of a tree

If you have a camp toilet, make sure it is downwind from your tent

## Card 2

### PLAN AN IDEAL LAYOUT OF A CAMPSITE WITH THE CARDS PROVIDED

## Card 2

### CHECKLIST CAMPSITE LAYOUT

- Is the tent well sheltered?
- Is the camp fire in a safe location?
- Do you see any dangerous situation at the campsite?

## Creating a form of ground insulation

At night it is important to maintain your body heat. Most of your body heat is lost through your head and to the ground. Using a well insulated ground mat and covering your head will help to warm and insulate you.

### MAKING A GROUND MAT

Making a ground mat, you will need:

- string
- binliners (large)
- newspapers
- blanket.

#### Guidelines

1. Fill the binliner with crumpled newspaper. Pack newspaper tightly into binliner. Squeeze the air out of the bag and tie the top with a piece of string using a reef knot.
2. Slip the binliner inside another one to waterproof it. Tie string around the top of this bag, again using a reef knot. Ideally you should slide the knotted end of the filled bag into the empty binliner.
3. You may need to fill two or three binliners depending on your height.
4. Lay the binliners end to end and put a blanket on top tucking it in under the binliners to keep them snugly together for comfort. When you sleep on your ground mat the newspaper will absorb the cold from the ground and keep you warm. It is important to keep the ground mat dry.

### Card 3

**MAKE A FORM OF GROUND INSULATION FOR YOUR CAMP WITH THE MATERIALS PROVIDED**

### Card 3

#### CHECKLIST GROUND INSULATION

- Is the ground mat well insulated?
- Is it waterproof?
- Does it feel comfortable to lie on?

## Building a shelter

Everyday materials can be used to create a shelter for use in rain and strong winds.

**BUILDING A SHELTER**

**MATERIALS**

- Tennis ball cut in half
- Penknife
- Matches
- Ground sheet
- Sticks
- Sheet of plastic (2m x 4m)
- Cord
- Round pebbles
- Stones or bricks

**GUIDELINES**

1. Get a strong sheet of plastic. Open it out and lay it on the ground.
2. Attach a cord to each corner of the sheet and to the centre of the longer sides.
3. Wrap the sheet corners around the round pebbles and tie the cord around the sheet corners and pebbles securing with a reef knot.
4. Wrap the cords loosely around large stones or bricks to hold the sheet down. Tie half-hitch knots in the wrapped cords around pebbles to secure them onto the stones or bricks.
5. Use the two cut tennis balls to attach the sticks to the plastic sheet as uprights. Slide the tops of the sticks into each end of the folded sheet. Push the sticks into the ground and pull the sheet to make the sheet form a triangular shape (the tennis balls prevent the sticks from puncturing the plastic at the apex).
6. Adjust the stones to tighten the plastic sheet on the shelter. This will also ensure that the rain will run off the shelter. To make your shelter more comfortable put a waterproof ground mat inside. Make sure the ground sheet is not sticking out as rain will collect on it and flood the shelter. Also ensure that the edges of the shelter plastic are not touching the ground.
7. Students should not enter the shelter until it is safely secured.

### Card 4

**MAKE AN OVERNIGHT SHELTER FOR 2 / 3 PEOPLE WITH THE EQUIPMENT PROVIDED**

### Card 4

**CHECKLIST**

**OVERNIGHT SHELTER**

- Is the shelter well secured?
- If it rained would you keep dry inside?
- Is it safe?

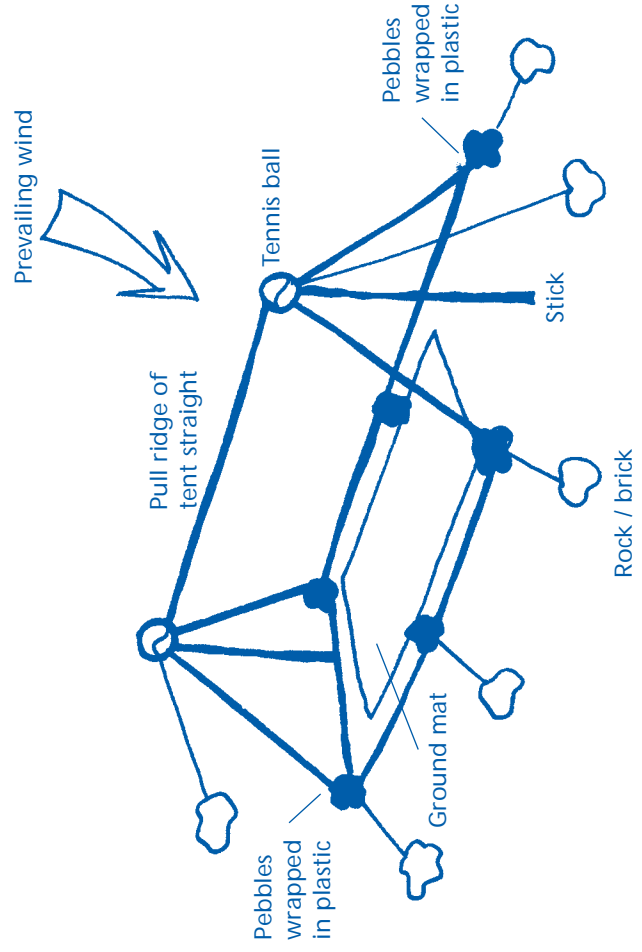

## Making a clothes line

It is important to have clean and dry clothing and camping equipment, for hygiene, comfort and safety, when living and working in your camp

### MAKING A CLOTHES LINE

#### MATERIALS

- strong rope for clothesline
- rope for handrail
- penknife

#### GUIDELINES

1. Tie one end of the strong rope around your tent pole or if necessary a tree nearest your tent. Secure the rope with a reef knot. Choose a tree with strong branches and use rope that will not stretch when you have clothes on it.
2. Tie the other rope end to a strong branch, ample distance from your tent or tree. Wrap the rope around the branch a few times, and again, secure with a reef knot.
3. Make sure to maintain the same height between tent and tree. Shoulder height is ideal.
4. With another rope, make a handrail leading to the toilet/latrine for night time use. Attach the rope exactly the same way as the clothes line with reef knots on both ends. Keep the handrail at waist height. Set up your camp toilet downwind from your tent.

### Card 5

**MAKE A  
CLOTHESLINE  
FOR YOUR  
CAMPSITE  
SUITABLE FOR  
DRYING OR  
AIRING YOUR  
CLOTHES**

### Card 5

#### CHECKLIST CLOTHES LINE

- Is it well secured?
- Can the knots be easily undone?
- Is it set at a good height?

## TASK CARDS

Card 1

PACK A  
RUCKSACK FOR  
AN OVERNIGHT  
CAMP IN MID-  
SUMMER

Card 2

PLAN AN IDEAL  
LAYOUT OF A  
CAMPSITE  
WITH THE  
CARDS  
PROVIDED

Card 3

MAKE A FORM  
OF GROUND  
INSULATION  
FOR YOUR  
CAMP WITH  
THE  
MATERIALS  
PROVIDED

Card 4

MAKE AN  
OVERNIGHT  
SHELTER FOR 2  
/ 3 PEOPLE  
WITH THE  
EQUIPMENT  
PROVIDED

Card 5

MAKE A  
CLOTHESLINE  
FOR YOUR  
CAMPSITE  
SUITABLE FOR  
DRYING OR  
AIRING YOUR  
CLOTHES

## TASK CARDS

## Card 1

CHECKLIST  
PACKING A  
RUCKSACK

- Is the rucksack waterproofed?
- Are emergency supplies e.g. first aid kit, wet gear, easy to access?
- Is the rucksack comfortable to carry?

## Card 2

CHECKLIST  
CAMPSITE  
LAYOUT

- Is the tent well sheltered?
- Is the camp fire in a safe location?
- Do you see any dangerous situation at the campsite?

## Card 3

CHECKLIST  
GROUND  
INSULATION

- Is the ground mat well insulated?
- Is it waterproof?
- Does it feel comfortable to lie on?

## Card 4

CHECKLIST  
OVERNIGHT  
SHELTER

- Is the shelter well secured?
- If it rained would you keep dry inside?
- Is it safe?

## Card 5

CHECKLIST  
CLOTHES LINE

- Is it well secured?
- Can the knots be easily undone?
- Is it set at a good height?



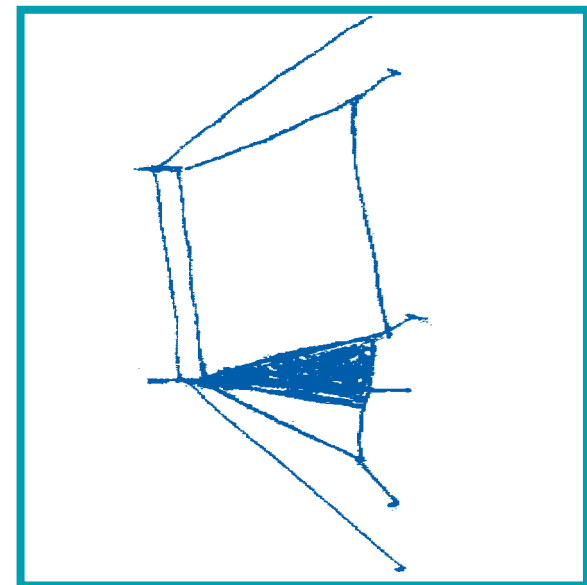
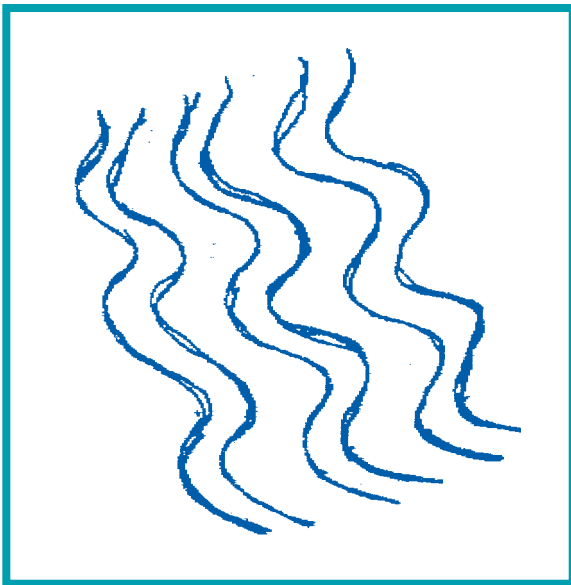
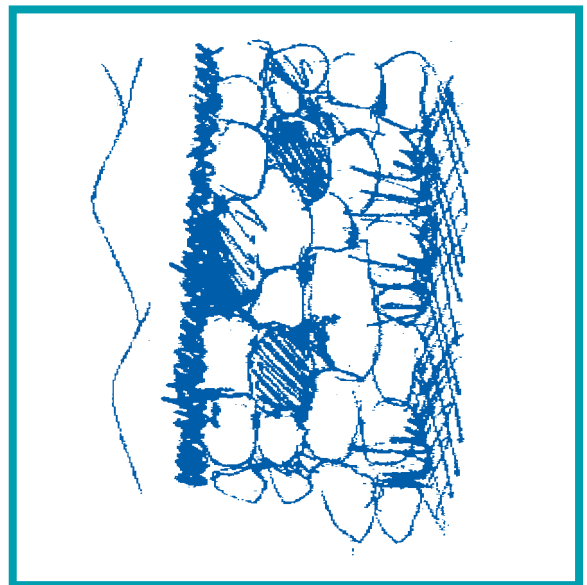
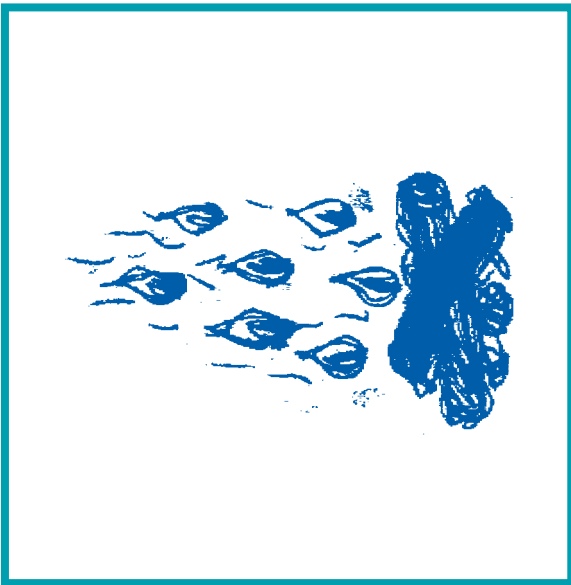
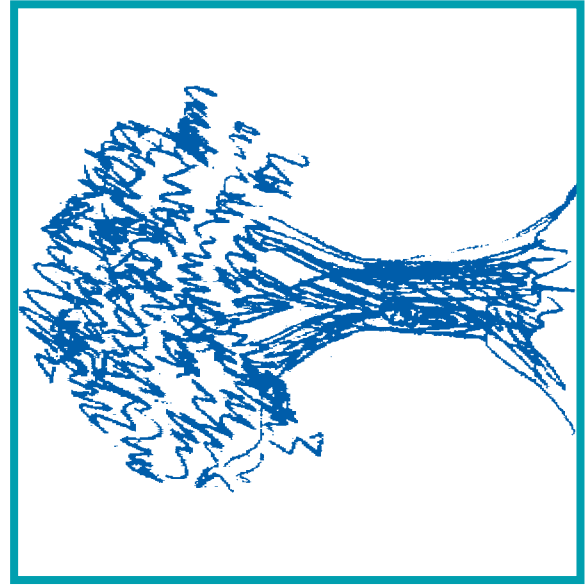
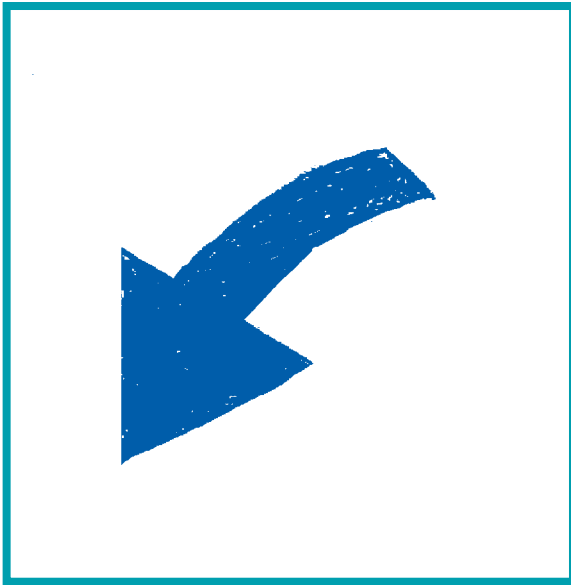

## ROCK CLIMBING / BOULDERING

## MINOR OBJECTIVES

**Bouldering** – on a climbing area no more than three metres high.

The student will:

- demonstrate safe practice in wearing appropriate clothing / footwear and by using a helmet
- apply basic movement techniques in traversing the wall
- demonstrate the use of three points of contact and appropriate transfer of weight
- display responsibility for other climbers through use of careful spotting.

## MAJOR OBJECTIVES

The student will:

- demonstrate the safe use of rock climbing equipment – helmet, harness, screwgate carabiners and ropes
- display appropriate use of rock climbing calls
- demonstrate a basic understanding of the operation of the belay system
- apply basic movement techniques for seconding or top roping simple rockclimbs
- demonstrate the use of a figure of eight knot to tie onto rope
- display an ability to second or top rope simple rock climbs
- complete an abseil using a friction device.

## HILLWALKING

## MINOR OBJECTIVES

The student will:

- understand and observe the country code
- display responsibility for their own safety in having the appropriate equipment, clothing and provisions required to complete a hill walk
- complete a walk in open mountain terrain.

## MAJOR OBJECTIVES

The student will:

- demonstrate a basic competency in the estimation of distance and timing
- identify symbols on 1:50,000 OS Discovery map
- demonstrate an ability to set the map
- identify a range of simple terrain features on the map and relate them to the surrounding countryside
- employ the skill of self-location using large terrain features
- identify potential weather and terrain hazards encountered in the outdoor environment
- describe and demonstrate the emergency call out procedure and appropriate action in the case of an outdoor accident / incident.

CAVING

MINOR OBJECTIVES

The student will:

- demonstrate an understanding of the importance of safety procedures (note of cave location and Estimated Time of Return) and use of appropriate equipment (need for spare lights, first aid, and food)
- learn of the dangers of entering a cave alone and implement practices which ensures the group stays together
- identify the processes responsible for the formation of cave passages and some features
- outline the importance of cave environment conservation.

MAJOR OBJECTIVES

The student will:

- extend their knowledge and application of safety procedures to include use of the "call out system", use of personal cave bag, ammo box and comfort sack
- develop and apply their knowledge in the use of equipment required for caving
- demonstrate an awareness of the hazards that may be encountered in caves
- display an awareness of personal and group safety in the application of team skills
- extend their knowledge of cave conservation in defining the importance of sediments and cave life forms.

SNORKLING (POOL WORK)

MINOR OBJECTIVES

The student will:

- identify and demonstrate the correct use of snorkelling equipment
- display their ability to use finning technique, and appropriate procedures in clearing their mask and snorkel
- identify and demonstrate entries (there are five of these) and surface dives used in snorkelling.

MAJOR OBJECTIVES

The student will:

- demonstrate and explain the use of forward and backward rolls
- demonstrate their ability to snorkel with the mask on their forehead
- demonstrate their ability to fin underwater for 25m
- gain a basic competency in the recovery and refitting of equipment underwater.

## SURFING

## MINOR OBJECTIVES

The student will:

- identify the basic elements of surf equipment and demonstrate an ability to carry the board effectively and safely
- implement practices (including action on leaving the group) to ensure their own and others safety and demonstrate an awareness of hazards that may be encountered in the beach environment
- demonstrate the correct techniques of:
  - entering the water
  - catching a wave (toboggan)
  - stopping the board
  - trimming the wave
  - 1-2-3 stand-up
  - board control
  - use of leash
- appropriate action on wipe-out
- identify and demonstrate the correct hand / body position, and exhibit a basic understanding of fault correction.

## MAJOR OBJECTIVES

The student will:

- demonstrate and refine the skills and techniques outlined in the minor option and demonstrate their ability to catch a wave by paddling
- gain a basic knowledge of the history of surfing
- describe and apply their knowledge of tides,, wind and weather and understanding of waves in order to maximise their performance and ensure their safety
- apply appropriate measures to ensure their own and others safety.

## KAYAKING

## MINOR OBJECTIVES

The student will:

- list and explain the basic safety rules of canoeing
- demonstrate an ability to:
  - enter and exit kayak correctly
  - forward paddle, reverse paddle and stop
  - turn in both directions while stationary, using forward and reverse sweep strokes
- complete the capsized drill.

## MAJOR OBJECTIVES

The student will:

- identify potential dangers in the kayaking environment
- demonstrate an ability to:
  - turn in both directions while stationary using a combination of forward and reverse sweep strokes
  - paddle sideways
  - use a low brace on both sides
  - edge the kayak while it is moving
- display an ability to assist in an "Assisted X Rescue" .

## DINGHY SAILING

### MINOR OBJECTIVES

The student will:

- demonstrate an awareness of personal safety:
  - through the correct use of personal buoyancy
  - by wearing appropriate clothing
  - by staying with a capsized boat
- identify wind direction through use of its indicators
- identify and demonstrate their ability to use:
  - tiller
  - main sheet
  - jib sheet
  - rudder and centre / dagger board up haul and down haul
- helm a sailing dinghy while "reaching" or sailing across the wind
- stop the boat (lying to)
- explain what a tack is (turning front of boat through wind)
- helm a single-handed dinghy through a tack or crew in a multi-handed dinghy while tacking.

### MAJOR OBJECTIVES

The student will:

- assist in rigging a sailing dinghy
- list and identify the basic parts of the boat and its rig
- demonstrate an ability to get the boat out of "irons"
- demonstrate an ability to sail up wind and down wind
- explain what a gybe is (turning back of boat through wind), and attempt this manoeuvre.



- Entries
- Stroke Technique & Development
- Aquafit
- Personal Water Safety
- Flotation
- Streamlining
- Symmetry
- Asymmetry
- Partner Work
- Assessment

# Aquatics

*safety aquafit*  
*breathing technique*  
*survival rescue*  
*propulsion*





# CONTENTS



	<i>Page</i>
<i>Introduction</i> .....	<b>88</b>
<i>Overall Aim and Objectives</i> .....	<b>88</b>
<i>Teacher Guidelines</i> .....	<b>89</b>
<i>Level One</i> .....	<b>93</b>
<i>Learning Outcomes</i> .....	94
<i>Content Framework</i> .....	95
<i>Units</i> .....	96
<i>Resource Material</i> .....	102
<i>Level Two</i> .....	<b>115</b>
<i>Learning Outcomes</i> .....	116
<i>Content Framework</i> .....	117
<i>Pre Aquatics Planning Session</i> .....	118
<i>Units</i> .....	119
<i>Resource Material</i> .....	125

## **RATIONALE**

*Aquatics for HEALTH, SAFETY, FITNESS and FUN.*

Aquatics has a unique place in a balanced physical education programme. It provides students with a water-based learning experience through participation in a broad range of structured activities. It provides opportunities for physical, psychological and social development of each student.

## **PHYSICAL BENEFITS**

- Students of all ability levels can develop a range of skills in the water.
- Students can improve stamina, functional capacity and local muscular endurance without undue strain on the joints.
- Students will have the opportunity to develop a range of skills which can be used throughout their lives.

## **SOCIAL BENEFITS**

Aquatics provides an opportunity to participate in physical activity which can:

- be enjoyed with family and friends
- develop an awareness of safety in or near water
- provide opportunities to share responsibilities and co operate with others
- become involved in competition at appropriate levels
- assume different roles and responsibilities i.e., personal safety, co-operation, care of others.

## **PSYCHOLOGICAL BENEFITS**

Students can experience:

- an appreciation of personal success
- an improved self-image and sense of independence
- an enhanced feeling of well being
- an opportunity to experience risk and challenge.

*for  
health,  
safety,  
fitness  
& fun!*

## Overall Aims & Objectives

### **AIM**

To provide students with the opportunity to develop personally, socially and physically through participation in aquatics in a safe and enjoyable environment.

### **OBJECTIVES**

- *To develop confidence in the water.*
- *To perform at least one recognised swimming stroke competently and safely.*
- *To develop competence in and an understanding of basic water safety and life saving skills and an ability to make decisions having assessed hazards which relate to water activities.*
- *To demonstrate an awareness of the fitness requirements of aquatic activities and their value as a fitness promoting activity.*
- *To co-operate with others in the learning environment.*

# Teacher Guidelines

## METHODOLOGY

The detail of the suggested methodology will be, for the most part, addressed in the individual lesson notes. However there are some general points which can be introduced here.

- **Communication:** The teacher may communicate with students in one of three ways:

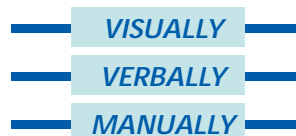

In practice, communication in the teaching/learning setting is usually comprised of a combination of two or more of the methods. Good communication needs clarity of signal, movement and words which results from the teacher having clarity of thought and a sound knowledge base from which to select material.

Poor communication often arises as a result of:

- *learner saturation*
  - *distractions*
  - *confused presentation of material*
  - *repetitive, unimaginative practices/activities.*
- **Motivation:** Learning is enhanced when the students are motivated to participate by a desire to improve. Motivation may be optimised in a number of ways, for example:
    - *setting realistic goals / achievement levels.*
    - *offering praise.*
    - *providing feedback.*
    - *using a variety of appropriate practices.*
    - *making sensible use of awards or incentive schemes.*
    - *using a variety of lesson formats.*
  - **Feedback:** This integral part of all lessons ought to be:
    - *immediate (as is practical)*
    - *focussed on single point*
    - *distinguished from praise*
    - *two-way i.e., students should be encouraged to express how they feel about what they are doing.*
  - **Demonstration:** Visual images can have a considerable impact on the students' subsequent attempts to improve their performance. There are a number of points which need to be considered in this regard.
    - **Accuracy:** *Care must be taken to ensure that the image is exactly that which is intended to be conveyed*
    - **Demonstrator:** *Use of a demonstrator in the water is likely to have more of an impact on the students than a teacher demonstration on the pool side. Again the quality of the performance must be adequate to make the intended impression on the observers.*
    - **Words:** *The teacher must identify the verbal description he/she will use to emphasise particular points within the demonstration. Such verbal descriptions must be brief and clear.*
    - **Position of observers:** *Ensure that the students are in a position to see what it is that the demonstration is intended to show them e.g. sitting on pool side, standing.*

Note

L1 — Beginner

L2 — Intermediate

L3 — Advanced

## Lesson Organisation

### PREPLANNING

It is obviously essential that the teacher engages in adequate planning before the session(s). In using the lesson materials included below the teacher should take into account a number of considerations:

- *size of the group*
- *levels of ability*
- *range of ability*
- *experience of individuals.*

### GROUPING

In order to optimise the learning experience and to facilitate effective teaching it is frequently necessary to group students. Groupings might be made on the basis of:

- *technical ability*
- *endurance*
- *safety*
- *previous knowledge/experience*
- *water depth/individual height*
- *common strengths or weaknesses.*

### PRACTICE

To avoid student fatigue and/or boredom it is recommended that students are not required to perform more than 4 widths of any task.

### RESOURCES

In utilising the materials provided the teacher must take account of the following:

- *pool space available*
- *equipment required*
- *depth and temperature of water*
- *numbers of students in the water*
- *acoustics*
- *number of teachers.*

### HYGIENE AND CLEANLINESS

The teacher must ensure that students:

- *visit the toilet before the lesson*
- *enter the pool in a good state of general cleanliness (especially nose, hands, feet)*
- *wear a clean swimsuit*
- *shower before and after swimming*
- *don't swim if they have:*
  - *open wounds*
  - *infectious diseases*
  - *coughs, colds or related infections*
  - *ear infections.*



### Verrucae/Athletes Foot

Verrucae are only contagious **before** they are visible. Wearing pool socks does not prevent spreading verrucae and may only serve to increase the incidence of athletes foot. Pool socks may be worn **to the side** of the pool but it is not recommended in the water.

# Safety Checklist

*Safety in Aquatics is a very real concern.*

The following checklist can serve to heighten awareness of safety for all levels of aquatics teaching.

## **PRE-SESSION CHECK**

1. Dressing rooms are clean and safe.
2. Pool deck clear of obstacles.
3. Remind students to walk on pool deck and obey all pool rules, e.g. no pushing, no running, no eating, no jewellery, etc.
4. Check disability access.
5. Remind students to be conscious of their own safety and safety of others at all times.

## **POOL SESSION CHECK**

1. Lifeguard on duty.
2. Students know exactly where depth changes are.
3. Grouping of students must incorporate safety considerations.
4. Students must be reminded that "play acting" in water can result in students losing confidence.
5. Students must be under care of the teacher at all times.

## **POST SESSION CHECK**

1. Teacher makes sure pool deck is clear of obstructions.
2. The teacher is last to leave the pool.
3. Teacher checks the pool.

### **Important!**

Students should be reminded that school rules apply whether on or off campus.





# Aquatics

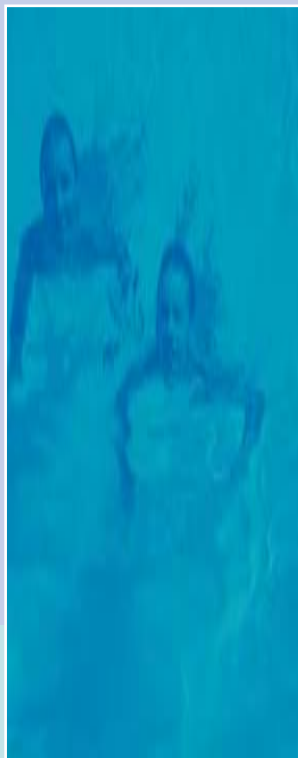

Level  
One

# Learning Outcomes

The student will (appropriate to their own level):

- *participate in variety of simple water games*
- *swim on front and back (in each case using a recognised stroke)*
- *select and perform appropriate water entry methods (where pool rules permit)*
- *perform basic personal survival skills*
- *demonstrate a knowledge of elementary principles of land-based rescue*
- *display an understanding of the benefits of swimming as an aerobic exercise.*





# CONTENT FRAMEWORK

ENTRY	UNIT 1 <i>Safe entry (wade)</i>	UNIT 2 <i>Feet first Assisted entry</i>	UNIT 3 <i>Feet first and/or head first entry</i>	UNIT 4 <i>Variety of jumps and dives</i>	UNIT 5 <i>Focus on head first</i>	UNIT 6 <i>Assess 2 entries</i>
STROKE	<i>Travel across pool</i>	<i>Push, glide and kick</i>	<i>Propel on front and back</i>	<i>Arm action, front and back, full stroke</i>	<i>Breathing technique</i>	<i>Propel 25m</i>
AQUA FITNESS	<i>Aqua warm-up jumping etc.</i>	<i>C.V. aqua activity</i>	<i>Pulse taking</i>	<i>Pulse taking</i>	<i>C.V. aqua circuit</i>	
SAFETY	<i>Personal safety</i>	<i>Talk rescue</i>	<i>Non-contact rescues</i>	<i>Survival skills, "Mushroom", "H.E.L.P.", "Huddle", signal for help</i>	<i>Land rescue &amp; survival skills (treading surface dives, evasive action)</i>	<i>Demo land rescue and survival skills</i>



## UNIT 1

The student will:

- *be able to enter the water safely feet first*
- *cross the pool*
- *participate in warm-up activity*
- *understand the rules of personal swimming safety.*

## UNIT 2

The student will:

- *demonstrate different ways of entering the water feet first*
- *demonstrate push, glide and kick technique*
- *participate in a series of aqua fitness exercises with emphasis on cardiovascular development*
- *learn talk rescue.*



## UNIT 3

The student will:

- *perform a feet first or head first entry*
- *move through the water on front or back*
- *take their pulse*
- *learn reach and throw rescue.*

## UNIT 4

The student will:

- *develop full strokes (back and front) - emphasis on arm action*
- *take each others pulse*
- *learn basic survival skills—Mushroom, Huddle & Signal.*

## UNIT 5

The student will:

- *perform new entry technique with head first in mind*
- *demonstrate an efficient breathing technique*
- *participate in simple aqua fit circuit*
- *be able to perform land rescue and survival skills, e.g. tread water, surface dives, evasive and skills.*



## UNIT 6: ASSESSMENT

The student will:

- *demonstrate 2 entry techniques*
- *propel themselves up to 25m*
- *perform rescue and survival skills.*

Unit 1: Entry, propulsion, safety  
**The student will:**

- enter the water safely, feet first
- cross the pool in a prone position
- understand rules of personal safety (refer to pool safety chart).

**LEARNING OUTCOMES**

**EQUIPMENT**  
 Floats

**CLASS ORGANISATION**  
 Assess (verbally and practically) all students in shallow end to determine ability prior to commencement.

STAGE	CONCEPT	CONTENT / ACTIVITY	TEACHING POINTS
Introduction	Safety	Personal and group safety rules.	Safety - respond quickly to signals. Stop means stop 1 blast - stop      2 blast - out of pool • No running on pool deck • No gum • No pushing • No jumping into crowded areas.  Shower before using pool. Use footbath.
	Hygiene		
Development	Water Confidence	2 Width assessment: • On front      • On back  Splashing partner. See-saw. Touching bottom with different body parts, from standing / sitting / floating Paired games. (See pg. 112)	• Change partners frequently. • Partner students of different ability levels.  See resource material.
	Water Confidence	L1 Standing from prone position – using float to stand – without float L2 prone to supine to prone without standing	
Conclusion	Entry - feet first	L1 Ladder/Steps • Sitting Entry L2 Sitting Entry • Jump (crouch) L3 Jump • Star • Tucked	(a) Toes gripping pool edge. (b) Keep natural body alignment. (c) Completely submerge and push off bottom.  See resource material.
	Moving in water	L1 Walking - with shoulders in water Bouncing forwards / backwards L2 Walking with float - kicking with float (see resource sheet) Front crawl L3 Kicking across pool with floats Kick on side F.C.	Blowing/pushing a ball / egg flip / float.  Pushing float with head. Vary speed of walk. Encourage face in water.  Use floats to vary resistance. Focus on arm action. Face in/out of water. See front crawl resource material.

Unit 2: Entry, propulsion, rescue

### LEARNING OUTCOMES

The student will :

- experience different ways of entering the water feet first
- demonstrate push, glide and kick techniques
- participate in aqua fit exercises with emphasis on C.V. development
- learn a method of talk rescue.

### EQUIPMENT

Objects for recovery activity, floats.

### CLASS ORGANISATION

STAGE	CONCEPT	CONTENT / ACTIVITY	TEACHING POINTS
Warm up	Water confidence  Water confidence and co-operative activity	Pool walk across (Full class activity) Variations: Hop, jog, jump  <b>All groups together.</b> <b>Retrieval Activity (C.V. Activity)</b> In teams, recover objects from pool floor and return them to team corner. First team to recover 'x' items wins.	Shoulders under water. Hands in front.  Mid/shallow section of pool. • Emphasis on importance of warm-up. • Pulse raising nature of warm-up activity. Designate one corner/location for blue team and one for yellow team.
Development	Feet first entries  Stroke development	<b>L1: Crouch jump with/without buddy in water</b> <b>L2: Jumps</b> Straight • Tucked • Star <b>L3: Jumps</b> Straight • Tucked • Straddle  <b>L1: Revise prone to standing</b> Do supine to standing with/without an aid. <b>Push &amp; glide (using buddy system).</b> Front • Back • Leg kick at wall <b>L2: Push &amp; glide (with/without float)</b> Front crawl • Back crawl <b>L3: Push &amp; glide from side</b> At surface • Under surface using FC and BC leg kick Front crawl • Back crawl Experiment with non-streamlined positions. Introduce sculling.	See resource material.   See front crawl resource sheet. Emphasise streamline position. Push and glide. Note distance. Push and glide and take up T or X position in the water. (i.e., taking up a floating position on front or back, make the shape of a T or an X with your body)  Stroke cards (see resource material).
Conclusion	Talk rescue	In pairs. A lies on pool side, B in water in apparent difficulty. L3 group may try this rescue in deep water.  All levels—demonstration of same.	For subject: <ul style="list-style-type: none"> <li>• Signal for help making fist shape in the air.</li> <li>• Keep hands in water • Head up • Kick legs</li> </ul> For rescuer: <ul style="list-style-type: none"> <li>• Reassure subject • Talk them to side</li> <li>• Encourage 'victim' to paddle • <b>No body contact</b></li> </ul>
Cool down (optional)		Slow width swim	Choice of stroke.

Unit 3: Entry , propulsion, pulse taking, non contact rescue

### LEARNING OUTCOMES

The student will :

- perform a feet first and/or head first entry
- move through the water on their fronts and backs
- participate in simple C. V. activities and pulse taking
- learn reach and throw rescue.

### EQUIPMENT

Rescue equipment, towels, ropes, poles, clothes, floats, rings,

### CLASS ORGANISATION

STAGE	CONCEPT	CONTENT / ACTIVITY	TEACHING POINTS						
Warm up	Water confidence	Statue tag: 'tagged' person must stand or float at point where they were tagged. Released by having others swim between their legs or underneath.	Nominate catchers. Use shallow end.						
Development	Entry techniques  Entry: Feet first Head first  Stroke development  Cardiovascular endurance	<p>L1: Crouch jump with/without float Straight jump with/without float</p> <p>L2: Straight &amp; star jump Sitting and kneeling dive</p> <p>L3: Revise jumps Dives • Sitting • Kneeling • Crouch • Standing</p> <p>L1: Push &amp; glide with/without float (front) Push &amp; glide with/without float (back) Introduce leg action</p> <p>L2: Front Crawl • Back crawl</p> <p>L3: Emphasis on leg action.</p> <p><b>C.V. Activities</b> Jogging across pool • Walking shoulders under water • Star jump • Tuck jump • Volleyball block • Twist • Object retrieval</p> <p>All levels—Pulse taking, carotid and femoral pulse.</p>	<p>Buddy in water for assistance.</p> <p>See resource material.</p> <p>Emphasise streamlining. See front / back crawl resource material.</p> <div style="border: 1px solid black; padding: 5px; width: fit-content; margin: 10px auto;"> <table style="border-collapse: collapse;"> <tr> <td style="padding: 2px 10px;">4</td> <td style="padding: 2px 10px;">3</td> </tr> <tr> <td style="padding: 2px 10px;">1</td> <td style="padding: 2px 10px;">2</td> </tr> </table> </div> <p>Shallow end</p> <p>See Aqua Fit resource material. Emphasise: Increased heart rate. Good posture during exercise.</p> <p>Mention the effect of water on the heart rate. Note effect of different activities on heart.</p>	4	3	1	2		
4	3								
1	2								
Cool down	Reach Rescue	<p>Walk</p> <div style="border: 1px solid black; padding: 5px; width: fit-content; margin: 10px auto;"> <table style="border-collapse: collapse;"> <tr> <td style="padding: 2px 5px;">3</td> <td style="padding: 2px 5px;">2</td> <td style="padding: 2px 5px;">1</td> </tr> <tr> <td colspan="3" style="text-align: center; padding: 2px;">Rescue at varying distances from side</td> </tr> </table> </div> <p>Shallow end</p> <p>PRACTICE SETUP</p>	3	2	1	Rescue at varying distances from side			<p>Rigid objects: Poles • Buoyancy rings • Extended poles with rings • Floats. Choice of object depends on distance.</p> <p>Non rigid objects: Towels • Ropes • Clothes Choice depends on circumstances.</p> <p>N.B.: Maintain safety of rescuer. No contact with subject. Importance of continuous communication with subject. Keep eye contact. Emphasise the importance of personal safety.</p>
3	2	1							
Rescue at varying distances from side									

Unit 4: Arm action, personal survival skills

**LEARNING OUTCOMES**

**The student will :**

- develop full stroke technique - back and front crawl
- practice pulse-taking techniques
- learn basic survival skills (“Mushroom float”, “H.E.L.P.” and “Huddle”, signal, treading water).

**EQUIPMENT**

Floats (one per student), resource cards.

**CLASS ORGANISATION**

STAGE	CONCEPT	CONTENT / ACTIVITY	TEACHING POINTS
Pre Class Work	Personal Safety	H.E.L.P. (Heat, Escape, Lessen, Posture) and Huddle	Groups of five plus, adopt huddle position.
Warm up	Stretching	Using an entry of choice: L1: Cross pool using arms and legs with/without float L2: Cross pool - back crawl, front crawl (full stroke) L3: Choice of stroke  Full body stretch. Arm and leg stretches.	4 widths. Check pulse before and after warm-up activity.
Development	Stroke technique	L1: Front crawl arm action L2 & L3: Front / back crawl arm action	Arm stretch - Biceps and triceps Leg stretch - calf, quadriceps, hamstrings
	Personal safety float	L1: Mushroom float - with buddy and/or float L2: Mushroom float to handstand L3: Mushroom float - time challenge	See BC / FC resource material. Emphasise entry, pulling action, finish, effective body position
	Treading water	L1: Treading water with two floats beside a wall. L2 & L3: Treading water in groups	Line activity Treading water activity 1 2 3 4 5 6 x x x x x x Direction of movement →
	H.E.L.P. (Heat, Escape, Lessen, Posture)	HELP position can only be used with a buoyancy device.	Teacher calls number - student swims to front of line, others tread water.
Cool down	Huddle	Huddle position is practical only in shallow water if no buoyancy aids are available.	• Hugging float, tuck knees close to chest. • Used when alone and wearing a life jacket to conserve heat. • In groups of three or more, in circle formation, get as close as possible together.
	Huddle manoeuvre	L1: Run L2: Run/swim L3: Swim	Explain procedure and purpose. Students move about, form huddles of size specified by teacher's call. Note effect on heart rate.

Unit 5: Breathing confidence, head first entry technique, survival - personal skills

### LEARNING OUTCOMES

- The student will :
- develop entry techniques
  - demonstrate efficient breathing technique
  - demonstrate ability to recover objects from the bottom of the pool.

- EQUIPMENT**  
Coloured objects, floats.
- CLASS ORGANISATION**

STAGE	CONCEPT	CONTENT / ACTIVITY	TEACHING POINTS
Warm up	Water confidence Co-operation	Retrieval of coloured objects to four corner points in shallow end.	Students spread out over the given area. Several coloured objects are on floor of pool. On whistle, each team retrieves its own coloured objects and takes them to its corner.
Development	Stroke improvement	<p>L1: Breathing practice in crouch position See-saw with partner Walking, pushing float with forehead</p> <p>L2: Prone kick at side of pool to practice breathing Kicking with float across pool Swimming under partner's leg ( shark game) Back crawl. Leg kick only</p> <p>L3: Front crawl breathing exercise</p>	<p>See front crawl resource material. Intake on count of 1. Submerge face - on count of 2,3, blow bubbles. Hold partner's hands. Alternate submerging. Prone kick - breathing to the side, ear in the water.</p> <p>Side of face in water to breathe. Clear nose and mouth out of water. Breathe every 4 seconds.</p> <ul style="list-style-type: none"> <li>• One arm on float, other arm by side.</li> <li>• One arm on float, other arm pulling.</li> </ul> <ul style="list-style-type: none"> <li>• Breathing every 2 - 4 strokes. Bi-lateral breathing every 3 - 5 strokes.</li> <li>• With partner, synchronise the stroke across width of pool.</li> </ul> <p>Straight arm entry, little finger leads.</p> <p>Feet off bottom for 5 seconds. Arms move in a 'clean the table' motion. Hand stand important as preamble to successful surface dive.</p> <p>Bring arms up straight by your ears. Sink body down: sit, kneel, lie on bottom.</p> <p>In depth Just out of depth beside the wall.</p> <p>Timed 'treading water' - 1 min, 2 mins Include hand waves, surface dives, turn to right/left. Surface dive feet first, head first.</p>
Cool down	Water Safety	<p>L1: Crouch dive. L2: Standing dive. L3: Standing dive/straddle jump.</p> <p>L1: Treading water within their depth. Touch toes • Hand stand • Feet first surface dive</p> <p>L2: Treading water • Touch toes • Hand stands • Feet first surface dive • Head first surface dive</p> <p>L3: As above. Treading water with additional activities interspersed in the 'set time'. Retrieval of objects.</p>	<p>Stress importance of cool down: • Heart • Muscle</p>



Resource material: Unit 1

1. ENTRY INTO THE WATER FROM SITTING POSITION

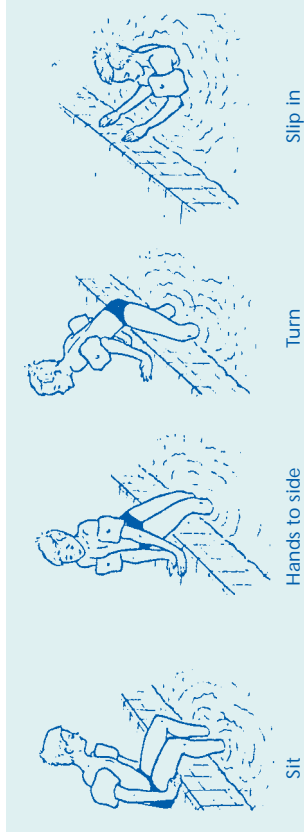

2. REGAINING THE FEET FROM THE PRONE POSITION

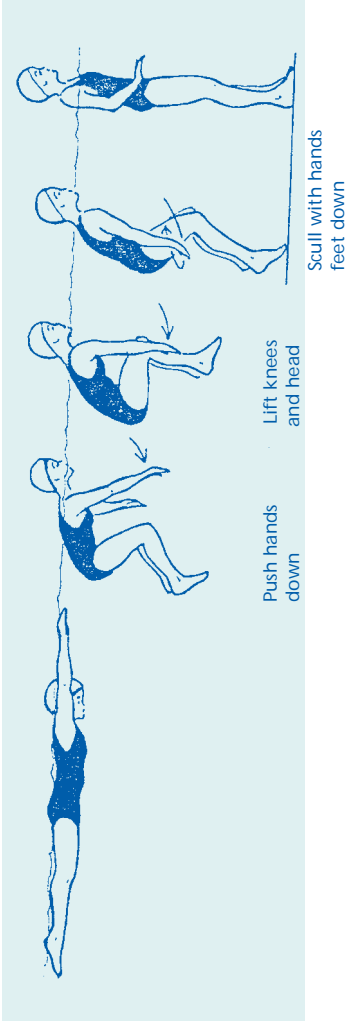

3. FLIGHT - STRETCHED SHAPE

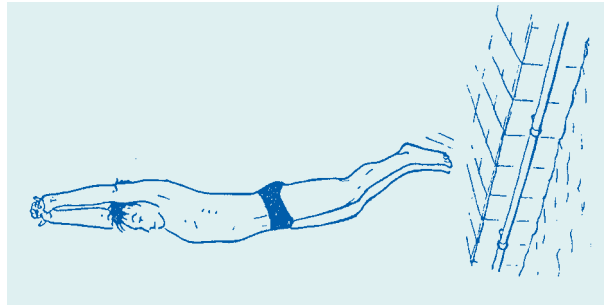

(i) Long and thin, hands stretched above the head in the flight with the hands clasped

Head held in alignment with the spine, eyes looking slightly upwards. On take-off the arms lift forwards and upwards reaching high. After the peak of the jump the arms sweep sideways and downwards to the thighs for the streamlined entry.

Water depth 1.8 metres minimum

FLIGHT - TUCKED SHAPE

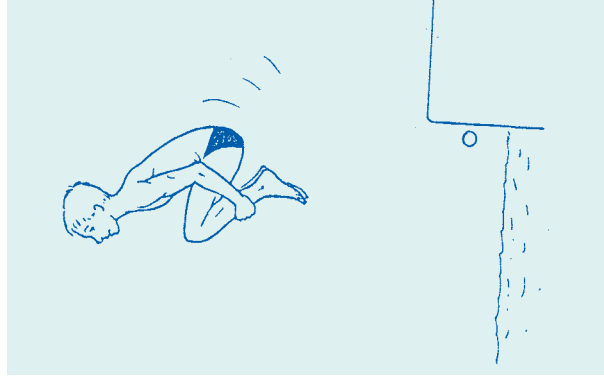

(ii) Tucked position on the flight

Body extended on take-off as opposite. Then knees brought up to the chest with the hands gripping the lower legs. The head must be kept up with the eyes looking forwards. Shoot the feet downwards for a vertical entry as in a stretched jump opposite.

(Water depth 1.8 metres minimum)

Safety

These jumps should always be taken from a standing take-off into water of adequate depth related to the height and weight of the swimmer. There must be clear signals given for entry and return to the side.

KICKING PRONE - PRACTICES

- (i) With float, face in/out of water
- (ii) Kick on side across pool
- (iii) In glide position, kick for 5 seconds followed by one arm action into glide position (repeat)

4. REGAINING FEET FROM SUPINE

- Bring arms forward
- Chin to chest
- Knees to chest
- Stand



**TEACHING POINTS**

These practices should be executed in a minimum of 1.8 metres.

**SITTING DIVE - INTRODUCTION**

Providing the early confidence practices have been mastered, including a surface dive, it is not generally necessary to use a sitting dive however, some students find this a comfortable and stable starting position. However, the design of the pool might make the starting position difficult to achieve. For a head first entry it is necessary to lift the body weight from the very stable sitting position; some people achieve this by standing on the trough or rail, which may present a slippery base. It is very difficult to perform in a deck level pool where an astride standing position is preferable.

**SITTING DIVE - DESCRIPTION**

The students sit on the edge of the pool with their feet resting on the rail or trough. The feet and knees may be together or slightly apart. The arms are raised above the head with the hands gripped tightly. The student bends forward and raises the hips to over-balance into the water. The feet should remain in contact with the rail until the body is submerging. It is a roll into the water.

**KNEELING DIVE**

The same roll into the water may be taken from a kneeling starting position. Many people find this an uncomfortable starting position, particularly where the poolside is rough. A lunge dive is probably a more comfortable option. A kneeling position is taken up with one knee close to the pool edge and the toes of the front foot firmly gripping the edge. The toes of the rear foot are curled under to give a base from which to push. With the arms stretched above the head the body rolls forwards to touch the forward knee. As the body overbalances there is a push from the feet and the body stretches out into a glide position underwater.

**CROUCH POSITION**

Crouching on the poolside with the feet together and the knees apart, the toes gripping the edge. The arms are extended above the head with the hands clasped together. Bend forward, keeping the head between the arms, overbalance and stretch towards the water. It is a roll into the water with a hip lift to go into the extension. The chin should be on the chest.

**LUNGE POSITION**

One foot is placed at the edge of the pool with toes gripping the edge. The other foot is stretched behind with the toes just touching the floor. The body is inclined forwards as the back leg lifts like a see-saw. The body overbalances, the lift of the rear leg controls the overbalance and gives a good body line. As the hands reach the water the front leg joins the other leg to give a good entry position. The head must be kept between the arms and the speed of the leg lift controlled. It is a fall into the water.

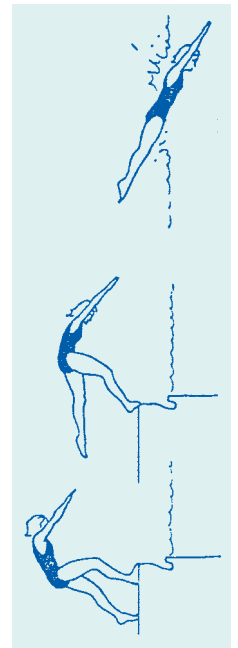
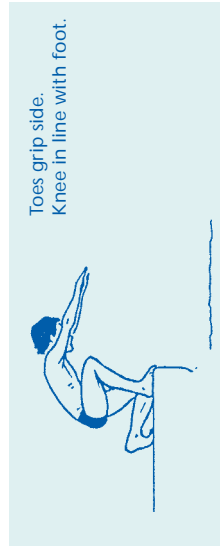
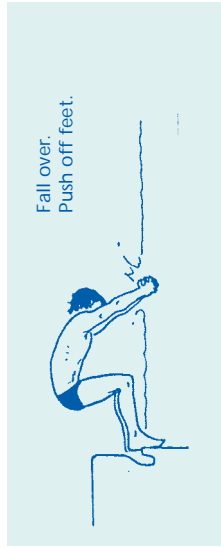
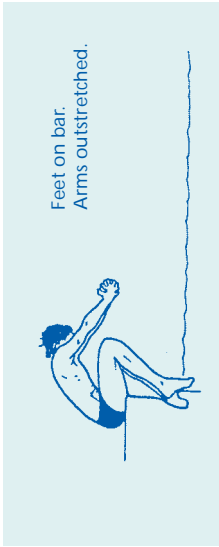

# TALK

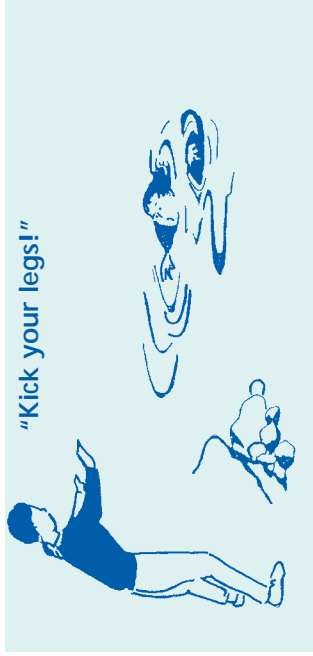

## VOICE CONTACT

It may be sufficient simply to calm the subject and encourage him/her to move to safety. Voice contact is an essential ingredient in the simple techniques described here as it is assumed that in almost all cases the subject is conscious and must be reassured that rescue is close at hand.

# REACH

## REACHING RESCUES

Here, the rescuer should lie prone on the ground, to avoid being pulled into the water. The reaching hand may grasp the subject or be grasped. This simple reaching rescue may also be used from a position in the water. To ensure his/her own safety, the rescuer should use his/her free hand to hold on to a firm support such as a tree branch and so enable himself/herself to draw the subject firmly to safety. An article of clothing, a branch, a plank or an oar can be used to extend the reach of the rescuer. Voice contact is essential to enlist the subject's co-operation.

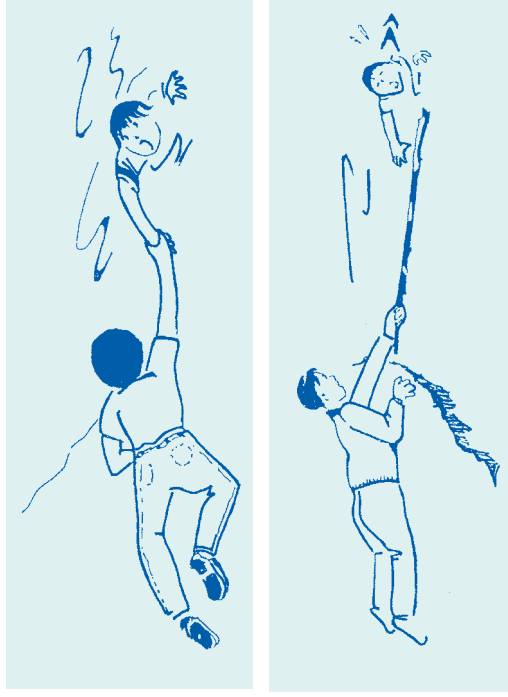

# THROW

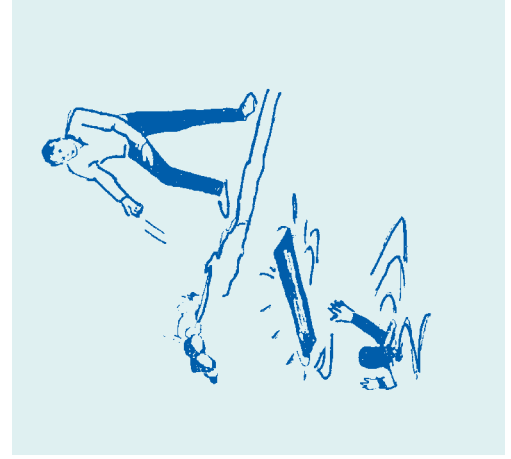

## BUOYANCY AIDS

Should the subject be out of arm's reach, it is possible to give him/her temporary support by pushing or throwing a buoyant object to him/her. While this may support him/her, rescue still has to be effected but, at least, he/she is safe while the rescuer has time to consider his/her next action. Voice contact with the subject should be maintained in order to reassure him/her or even encourage him/her to 'kick' his/her way to safety while supported by the buoyant aid.

Free-floating supports may be used with great caution. The support or buoyancy aid must reach the subject at the first attempt, and he/she must be sufficiently calm to grasp and maintain a firm hold as instructed by the rescuer. Such support is useful in stabilising a dangerous situation until a positive rescue action is initiated.

**HELP**

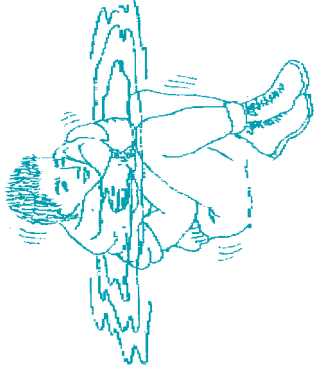

This, the heat escape lessening posture or foetal position can only be properly adopted using a buoyancy device and more particularly a life jacket. It allows most areas of high heat loss to be protected. HELP is assumed by drawing the knees up towards the tucked-in chin and pressing the arms close to the side.

**HUDDLE**

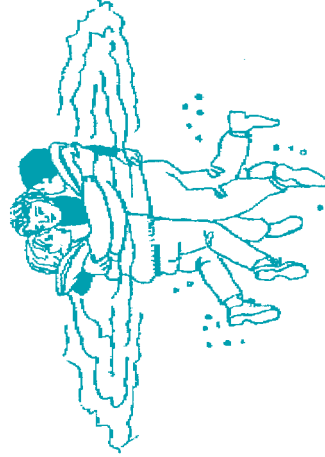

Based on the same principle as HELP, the HUDDLE position was developed for adult groups of three or more. The sides are pressed together, lifejackets are tied on behind the back and the groin and lower body areas pressed together. The basic principle is to decrease surface area to reduce cooling. In addition to the physiological results there is a psychological advantage of being together as opposed to floating in isolation.

**TREADING WATER**

Treading water is an essential survival skill for use in deep water. It enables the swimmer to save a certain amount of energy and to assess the situation.

**TEACHING POINTS**

- The swimmer remains in one spot.
- Body in a vertical position, head just clear of the water.
- Arm action: sculling at water surface (movement not unlike smoothing sand down on top of a table with arms moving simultaneously towards and away from each other).
- Variation: doggie paddle.
- Leg action: breaststroke kick, scissors kick, egg beater kick, cycling action.
- Encourage continuous leg action and tipping of head slightly back.

**PRACTICES**

- In shoulder depth, float under each arm, try different leg kicks putting as little pressure as possible on the floats.
- With one float held with both hands practise leg action.
- Out of depth, hold bar at pool side with one hand and a float with the other.
- Practice floating skills out of depth but close to side. Encourage reliance on flotation skills.
- Extensions:
  - 360 degree turn
  - waving
  - shoulders out of water for 10 seconds.
- Tread water signalling with both hands.
- Tread water signalling with float / brick above head.
- Timed treading.
- Ball game in deep end.

**BREASTSTROKE KICK**

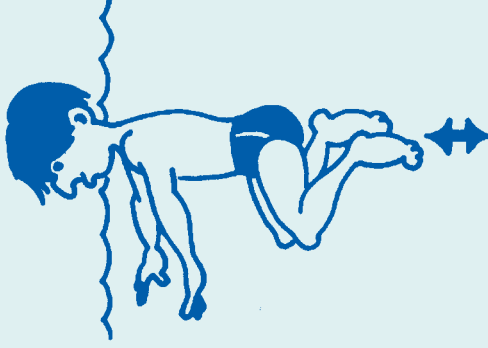

**SCISSORS KICK**

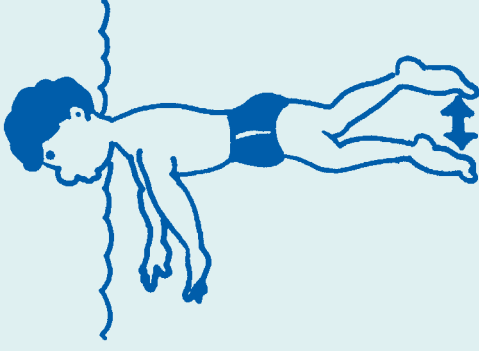

**EGG BEATER KICK**

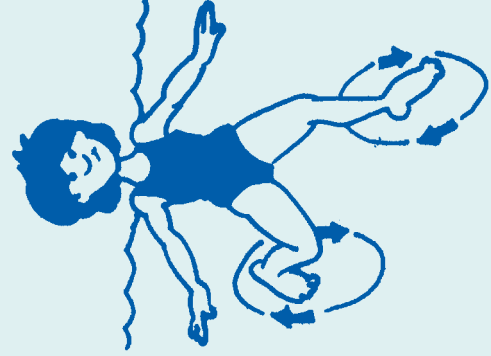

**CYCLING ACTION**

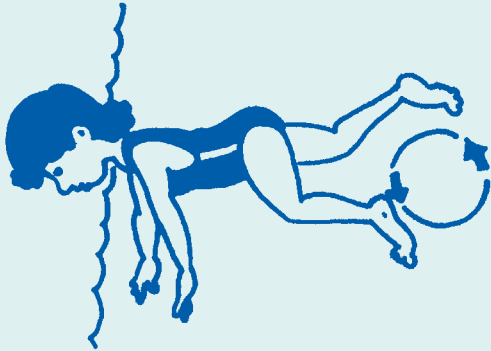

Resource material: Unit 5

## SURFACE DIVES

The swimmer may face danger on or under the surface. Submerging head or feet first should be taught. Such skills are also useful for promoting water confidence, retrieval of objects, life saving and fun activities.

### SURFACE DIVE, HEAD FIRST: Teaching Points

- Swim breaststroke at good pace.
- Look down into water.
- Extend arms to an underwater position in advance of the body.
- Strong BS pull to the surface. Pike position with body to an inverted L shape.
- Legs and feet should be together.
- Turn palms downwards and then press arms downwards to an extended position in line with the head. The legs are lifted as the arms press down. They should be held together and reach vertical.
- Submerge head first in a vertical and extended position.

### PRACTICES

- Standing position, touch your toes.
  - Standing position, try to jump to a hand stand position.
  - Hand stand from push and glide position:
    - head down
    - eyes open
    - lift hips
    - legs straight and together.
  - Surface dive through partner's legs or hoop.
- In deeper water**
- Swim BS, head up, then surface dive (hand stand action).

### SURFACE DIVE, FEET FIRST: Teaching Points

- Dive made from upright position.
- Make a strong downwards breaststroke kick. Co-ordinate with reaching both arms out of the water. As a result of the kick the body rises out of the water.
- Body is now streamlined and then sinks.
- Tuck forward to swim using large breaststroke arm and leg movements.

### PRACTICES

#### Shallow End

- Jump up and then sit on the floor of the pool.

#### Shoulder Depth

- Jump up, raise arms, sink to sit on the floor of the pool, keep arms raised above head.

#### Deep End

- Tread water, kick legs, kick down hard.
- Repeat, add raised arms and sink feet first.
- Repeat and add tuck/swim forward under water.
- Swim through weighted hoop at end of tuck.

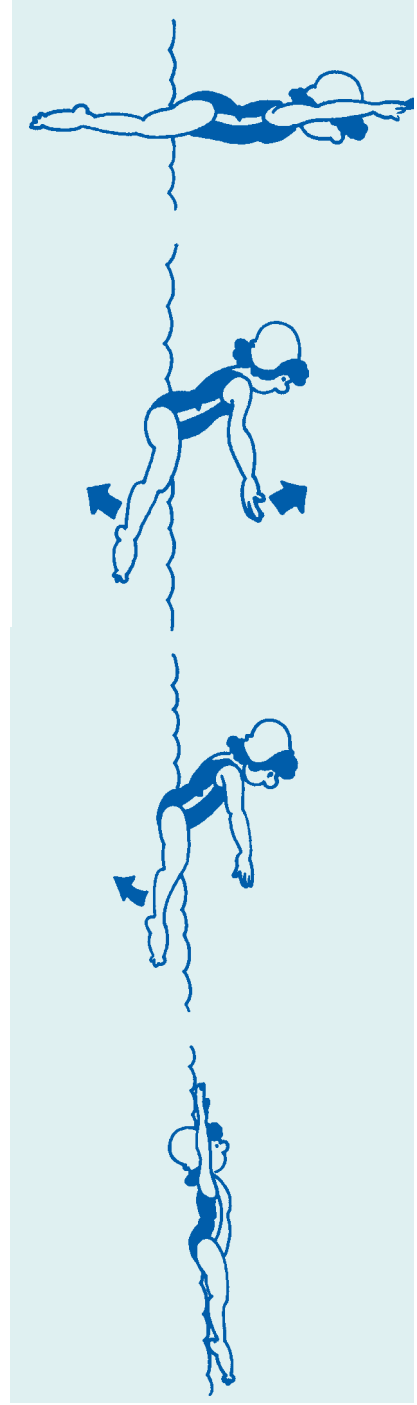

## STANDING DIVE

- Feet together on poolside
- Hands above head
- Lean forwards (only a little way)
- Push through legs and hips as the body tips forward
- Extend to entry
- Keep head between arms but look to entry point

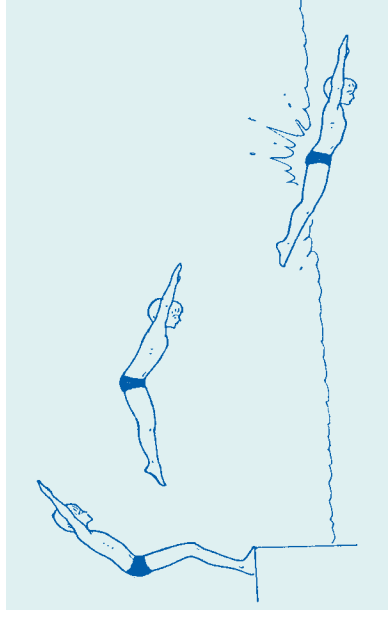

## STRADDLE JUMP

- On the poolside, one foot grip edge and the other back from the side
- Take off, eyes forward
- Top half of the body leans slightly forward and chest well out
- Arms lifted to shoulder level and elbows bent
- Some swimmers scissors kick on entry to create resistance, thus keeping them shallow

Resource material: Front crawl

### BODY POSITION

- Streamlined.
- Roll body to side to breathe.

### LEG ACTION

- Kick from hip and thigh.
- Stretch feet.
- Legs fairly straight and together.
- Floppy and relaxed ankles.

### ARM ACTION

- Continuous smooth action.
- Thumbs enter first.
- Pull through water to hips.
- Elbow lifts high out of water.
- Hand enters on line in front of head.
- Arm slightly bent.
- Stretch - Catch - Pull.
- Lean into the stroke.

### BREATHING ACTION

- Breathe to one side as one arm lifts.
- Turn head as little as possible.
- Keep eyes open.

## PROGRESSIONS AND PRACTICES

### BREATHING PRACTICES

- Hold the side of the pool with float in other hand and fully extend that arm. Submerge the face, turn to breathe.
- Two hands on float, practice breathing on both sides one arm extended. Turn away from that side to breathe.
- Practice while kneeling or standing in pool.
- Clear mouth and nose.
- Keep ear in water when breathing.
- Swim width using one breath only.

### LEG PRACTICES

- Push and glide on front, back and side. Y, I, T, X position.
- Push and glide and kick, with / without float.
- Kick and pull with one arm, other hand holds float. Turn face away from that side to breathe.
- Legs only with float under each forearm. Fingers grip end of float, knuckles touching.
- Catch up with a float. Alternate hand on float.
- Float in perpendicular position.
- Kick with head up.
- Kick on your side.

### ADVANCED PRACTICES

- Push and glide with float in 'resistance' (i.e., vertical) position.
- Kick on side (L/R). One arm extended, other arm sculling.

### ARM ACTION PRACTICES

- Standing arm action one foot in front.
- Push and glide, add a few arm action cycles.
- Single arm practices with one arm supported by float (change working arm at intervals).
- Doggy paddle practices. Arms do alternating pulling and reaching action under the water.
- Arm only using a 'pull buoy' (advanced).
- Arm action focus, high elbows, trail fingers through water to extended position.
- Arm action takes place completely under water.
- Full stroke practice - How many strokes to cross the pool? - How many strokes to swim a length?

### COMMON FAULTS

- Head too high; causes legs to drop.
- Too much knee bend renders kick ineffective.
- Arm swing 'out' rather than over.
- 'Flat' feet, must point toes.
- Too much splash.

**BODY POSITION**

- Streamlined.
- Side to side 'roll' as stroke is performed.
- Push & glide, add arm action.

**LEG ACTION**

- Legs kick alternately.
- Straight leg action.
- Kick from hips and thighs.
- Feet are stretched, big toes almost touching each other.
- Knees stay below surface.
- Ankles relaxed.
- Feet kick to the surface at the end of the up beat without splashing.

**ARM ACTION**

- Alternate.
- Little finger enters water first.
- Straight arm close to line of shoulder, brush ear with arm.
- Pull on entering water.
- Push before exiting water.
- Make an 'S' shaped down sweep.
- Little finger exits water first.

**HEAD POSITION**

- Face above water.
- Look over toes not at ceiling.
- Ears submerged.
- Look up and slightly towards toes.
- Pretend you are sunbathing and want to get your tummy tanned.

**P R O G R E S S I O N S   A N D   P R A C T I C E S****BODY POSITION ACTIVITIES**

- Using bar at side or two floats, adopt supine position, head back, ears in water.
- Push and glide adopting the same position.

**BREATHING ACTION**

- Take a breath as one arm recovers.
- Breathe out as other arm recovers.

**LEG ACTION**

- Push and glide from tuck position to stretch position.
- Push and glide with float
  - under each arm
  - held on stomach or chest
  - over hips (push hips up to float).
- Push and glide, hand/arms by side. Kick up to surface, churn up the water.
- Repeat, using sculling action with hands.
- Kicking action, arms at side, turning up left/right shoulder alternately with every 4/6 seconds.
- Push and glide, arms extended above head (advanced). 'Make the surface boil' with leg kick.
- Push glide and kick, float in a semi-submerged vertical position.

**ARM ACTION PRACTICES**

- Standing, practice the arm action with emphasis on long arms / continuity.
- Float held on chest, single arm action. Short distances only.
- Push & glide, add arm action.
- Pull along a large rope with one arm. Normal leg action (encourage bent arm in recovery).
- Reach back and pull through to thigh 'straight - bent - straight'.
- Arm only, pull buoy between legs (advanced).
- Double arm action: 'S' shaped action.
- Three arm pulls on right side, three arm pulls on the left side.
- Use pull buoy between legs and perform arm action.

**COMMON FAULTS**

- Head back too far.
- Knees bent too much.

Resource material: Auaafitness

**AQUA FITNESS**

In addition to providing students with experience in another aspect of aquatics, aqua fit activities provide opportunities for teaching concepts related to some components of health related activity. There is scope for sustained aerobic activity in a medium which reduces the impact related stresses on the body. A well structured aqua fit component in a lesson also allows students of all abilities to participate together in an activity.

In planning and implementing aqua fit activities in the aquatics lesson there are some points which should be taken into account:

- The pulse is approximately 10 beats per minute slower than on land-based activities due to the cooling effect of the water. This must be taken into account when calculating target training zones, e.g.

Age 14 years	Land-based activity	Water-based activity
Max Heart rate	208 bpm	198 bpm
Target Training Zone [60%-85% Max HR]	124-176 bpm	119-168 bpm
10 second count	21-29	20-28

- All aqua fit sessions must include warm-up, mobiliser and cool down.
- Water should be at chest height.
- Encourage students to establish a breathing pattern; exhale on the forceful motion and inhale on the recovery motion.
- Music may be used as background.
- Exercise in the water should be enjoyable and never hurt.
- Students should drink before and during session. No food within a period of 1.5 hr prior to exercise.
- Focus on correct posture. Upright throughout, toes turned out, knees over toes, keep knees 'soft'.
- Keep lower back flat especially as you walk backwards.

**AQUAFIT. CARDIOVASCULAR ENDURANCE TASKS**

If students are confident in the water these exercises should be done in chest deep water.

- (1) Pool walk (forwards and backwards)
  - Breaststroke arm action going forward.
  - In/out pressing action as you go back.
  - Gradually lengthen strides.
- (2) Cross-country ski action
- (3) Pool jog
- (4) Knee lifts
- (5) Twist
- (6) Tuck jumps
- (7) Cardio bouche
  - Feet apart, knees soft, spring forward as far as you can.
  - Bounce on the spot once.
  - Repeat this sequence as you progress across the pool.
  - Arms and cupped hands scooping forward at your side.

These exercises may be done initially for 1 minute increasing to 2 minutes continuous exercise.

Perform in a circle/across pool/in relay with partner.

Resource material: Aauafitness

#### GUIDELINES FOR AQUAFIT

- Water temperature should be between 26-29° C.
- Water level should be at chest height.
- Establish a breathing pattern with every exercise — inhale on the up and exhale on the down. Exhale on the forceful motion and inhale on the recovery motion.
- Stabilising positions  
Standing: feet apart or one foot in front of the other.  
Bar prone position: hold bar with two hands over-hand, under-hand or one hand on top, other below.  
Bar supine position: extend arms out to side or reach over shoulders and grasp bar.
- Music may be used as background and is helpful in enhancing motivation.

#### POSSIBILITIES FOR OVERLOAD

- Aerobic Activities:
- Increase the time spent on each exercise.
- Decrease the rest interval or make it more active.
- Increase the level of activity (e.g. walk up to jog).
- Increase the speed of the exercise from slow to fast.





Resource material: Aauafitness

**AEROBIC EXERCISES**

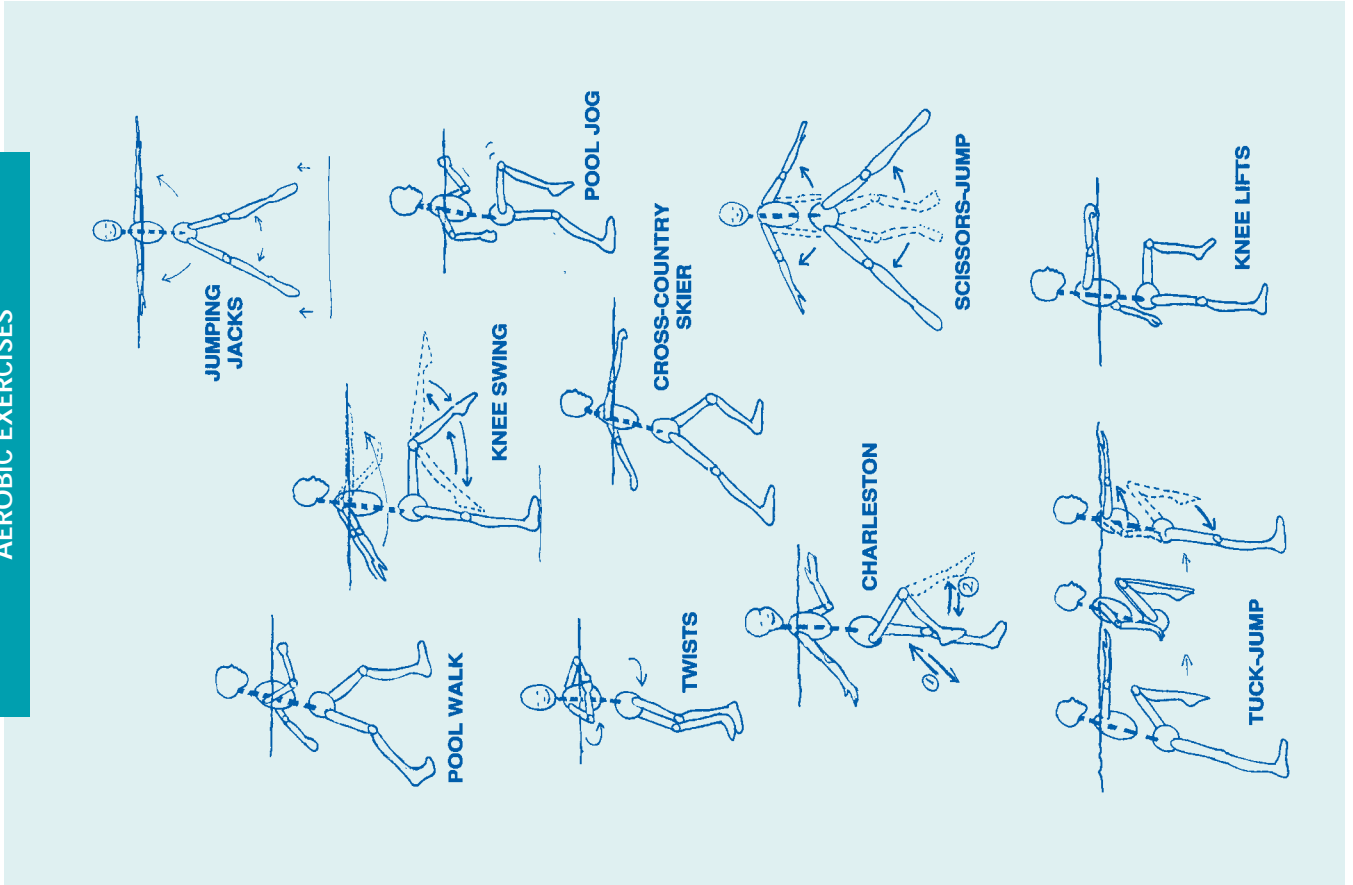

**MUSCULAR ENDURANCE**

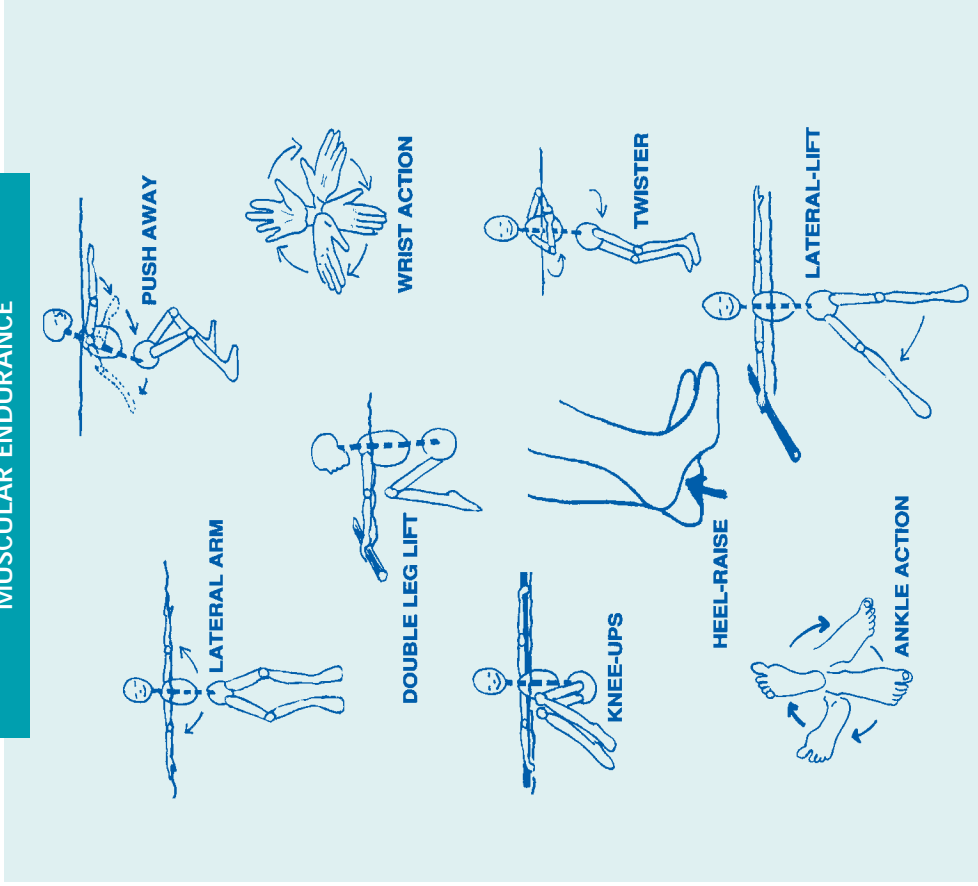

**EXAMPLE OF SWIM CIRCUIT**

Combining aerobic activity and muscular endurance exercise.

Walk/jog, swim with aid, swim full stroke — 1 width — on reaching pool side do 10 reps of lateral arm press.

- Walk 2 widths
- Walk 3 widths
- Walk 4 widths
- 10 reps of knee-ups
- 10 reps of scissors
- 10 reps of push away

Repeat sequence in reverse order from 4 widths down to one width.

## Water Confidence for Beginners

1. Legs only at rail
  - heels under
  - long legs
  - pointed toes
  - legs close together.
2. Using two floats
  - one at each side
  - chin on water.
3. One float extended
  - kick from hips.
4. Using two floats
  - ears under the water
  - floats vertical and to the side
  - float on chest legs only, knees under
  - silent kick.

### WATER GAMES

#### SIMPLE CIRCLE GAMES

Circles should be small for safety and involvement.

#### NUMBER RETRIEVE

With players in a circle, a ball is thrown into the circle as the teacher shouts a number. The player who has been allocated that number swims or dives to catch the ball and returns to the circle, throwing the ball back to the teacher.

#### KEEP IT UP

The aim is to keep a light ball in the air for as long as possible around the circle of players, who repeatedly throw or punch it upwards. This game readily lends itself to simple goal setting, by asking the group to score a given number of airborne shots.

#### SIMPLE GROUP GAMES

#### SHARKS AND MINNOWS

One player is 'shark' in the middle of pool. All others are minnows lined up along one side of the pool. 'Shark' shouts "sharks and minnows" and minnows have to cross to the other side without being caught by shark. Anyone caught stays in the middle and becomes a shark.

#### TRAFFIC LIGHTS

Three corners or sides of the pool are labelled as colours of the traffic lights. The teacher calls a colour and students have to move to the appropriate side as quickly as possible. This can also be an elimination game.

### MUSICAL GAMES

Played similarly to musical chairs or bumps, the students being given a selected task when the music stops. Tasks could be: lie or stand quite still (statue); pick up an object from the pool floor; find a hoop and go inside it; find a ball and throw it up and catch; find a float and balance with it.

#### TREASURE HUNT

Both sinkable and floating objects are scattered in the pool. The aim is to collect as many as possible. Each object is worth different points, those more difficult to retrieve being worth more. Different colours can be used, and students told to collect only the red objects, for instance.

### RACES FOR INDIVIDUALS OR PAIRS

#### CORK RETRIEVE

A number of corks are thrown into the pool; whoever collects the most wins.

#### LINKED SWIM

Swimmers link up with two or three others. So linked, they then swim the length of the pool. Through experiment the swimmers choose the most effective method of linking and travelling.

#### SHADOW SWIM

In pairs, one person swims underwater, and their partner attempts to 'shadow' their stroke on the surface.

### TAG GAMES

#### JAPANESE TAG

A tag game where the catcher touches a certain part of the body of the swimmer in order to catch the person out.

### STATUE TAG

When a swimmer is touched by the catcher, they must stand or float as still as a 'statue'. 'Statues' can be set free by someone else swimming through their legs, or swimming under them.

### HOOP TAG

One swimmer is 'it' and has to catch a replacement. By touching another swimmer the responsibility of being 'it' is transferred. Swimmers are only safe from being caught when within a hoop, holding a ball, or are underwater, according to the task set.

### PARTNER TAG

Two or three catchers initially tag another player. They then must remain linked in pairs as they move to try to tag and so eliminate all other swimmers. Those eliminated can be given a task. (With any tag game, a weak catcher can be aided by helpers).

### RELAY GAMES

#### DUCK FOR RING

Use sinking rings. Swimmers stand one behind the other in a line. Starting at the front, the ring is picked up from the bottom of the pool and dropped back over each person's head. The player behind has to pick it up again from the bottom of the pool, and so forth until the end player has received it. That person then swims to the front to start again.

#### DRESSING RACE

Team members swim across, collect an item of clothing, and wear it to swim back. The next player puts that on and also swims to collect a second garment to wear and so forth.

**OBSTACLE RACE**

Each member of the team has a different stunt to perform as they swim across, for instance a somersault, a handstand, a log roll, sculling across, taking a ball.

**OBJECT RACES**

Team members swim widths or lengths, having to carry a ball between knees, an object on the tummy, or a ring on the head. Other ideas include: with hands held out of the water, picking an object off the pool floor, going through submerged hoops, swimming whilst propelling a ball.

**BALL GAMES**

**PIGGY IN THE MIDDLE**

Three swimmers play this game, one standing in the middle attempting to intercept the ball thrown between the other two swimmers. Whoever throws the ball which the 'piggy' intercepts becomes the next piggy.

**PARTNERS**

This game is played with two teams of two. Each team counts the number of passes it can make with the ball before the other team intercepts.

**CLASS GAMES**

**ALL-IN TAG**

All students carry an arm band, except one student **wears** band. When caught all players must wear their band. Last one out is winner.

**RED LETTER**

All students against side. Teacher calls out letter. If letter in name move forward one step.

If "red" letter called nobody allowed to move. Move one step back if you do.

**INDIVIDUAL GAMES**

**HANDS GAME**

Partners make shapes / numbers. Other partner takes a breath to see.

**PLATE CATCH**

Leave an enamel plate sink. Retrieve. As confidence grows students may eventually retrieve from pool floor.

**TALL AND SMALL**

Reach up.  
Crouch down.  
Keep to a rhythm.

**CYCLING**

Using two floats cycle with feet. Try to get two feet off bottom.

**FLOATING SHAPES**

Using two floats, float.  
Experiment with different shape: Prone, supine, sideways, long shapes, wide shapes, asymmetric, symmetric - these can be done initially with partner.

**BOBBING**

Rise and sink while holding side, 2 hands. Submerge shoulders, face if possible.  
Side hold (one hand).  
Move to free standing as confidence grows.  
'Jack in the box' idea.

**SKIING**

Travel by sliding one foot after the other (this could be a relay game).  
Partner work if student nervous of leaving side.

**DUCK WALK**

Keep chin on water.  
Raise feet off bottom.

**CHEST BALL**

Push ball with chest around shallow end. (This could be a relay game for all levels).

**BLOWING BUBBLES**

Scoop water into hands, blow away vigorously.  
Lower face into water  
- who can blow for longest?  
- who can make a loud sound?  
- who can guess the name that underwater individual calls out?

**BLOWING OBJECTS**

Table tennis, cork, egg flips. Blow freely about pool. Later this could be a competitive game.



# Aquatics



Level  
Two

# Learning Outcomes

*The student will:*

- *demonstrate confidence through a variety of activities*
- *demonstrate at least one new aquatics skill*
- *show an understanding of swimming concepts (streamlining symmetry etc.) by answering the tasks in relevant and varied ways*
- *participate in tasks to heighten their awareness of personal safety*
- *submit a log of their learning.*



# Content Framework

Level 2 aquatics has been designed using a *thematic approach*. Each unit identifies a specific focus and a bank of tasks is included, through which students can explore the theme.

These tasks have been categorised in the same style as in level 1; i.e., stroke, entry, games and safety.

*Teachers should / can feel free to draw on or adapt to suit individual needs.*

	UNIT 1 (floatation)	UNIT 2 (streamlining)	UNIT 3 (symmetry)	UNIT 4 (asymmetry)	UNIT 5 (group work)	UNIT 6 (Assessment & Gala)
<b>ENTRY</b>	<ul style="list-style-type: none"> <li>• Straddle jumps</li> <li>• Slip in</li> <li>• Ways to submerge</li> </ul>	<ul style="list-style-type: none"> <li>• Jumps</li> <li>• Dives</li> <li>• Turns</li> <li>• Starts</li> </ul>	<ul style="list-style-type: none"> <li>• Jumps</li> <li>• Dives</li> </ul>	<ul style="list-style-type: none"> <li>• Shore entry</li> <li>• Sitting entries</li> <li>• Straddle</li> </ul>	<ul style="list-style-type: none"> <li>• Follow leader</li> <li>• Matching entries</li> </ul>	<ul style="list-style-type: none"> <li>• Assessment one entry</li> </ul>
<b>STROKE</b>	<ul style="list-style-type: none"> <li>• Breathing</li> <li>• Push 'n glide</li> <li>• Sculling</li> <li>• Modified strokes</li> <li>• Part of strokes</li> </ul>	<ul style="list-style-type: none"> <li>• Breathing</li> <li>• Breast stroke (new stroke)</li> <li>• Back crawl</li> <li>• Front crawl</li> </ul>	<ul style="list-style-type: none"> <li>• Double arm back crawl</li> <li>• Breast stroke</li> <li>• Dolphin kick</li> </ul>	<ul style="list-style-type: none"> <li>• Front crawl</li> <li>• Back crawl</li> <li>• Snorkling</li> </ul>	<ul style="list-style-type: none"> <li>• Contrast with partner</li> <li>• Synchronise stroke</li> <li>• Sculling</li> <li>• Group sculling</li> <li>• Routine</li> </ul>	<ul style="list-style-type: none"> <li>• Assessment</li> <li>• Choice of stroke</li> <li>• Breathing</li> </ul>
<b>WATER GAMES</b>	<ul style="list-style-type: none"> <li>• Exploration of floatation aids</li> <li>• Treading</li> <li>• Circle game</li> <li>• Floating tag</li> </ul>	<ul style="list-style-type: none"> <li>• Endurance relay</li> <li>• Swim outside body line</li> <li>• Water polo</li> <li>• Towing</li> </ul>	<ul style="list-style-type: none"> <li>• Circuit</li> <li>• Jumping</li> <li>• Back jumps</li> <li>• Volleyball block</li> </ul>	<ul style="list-style-type: none"> <li>• Throwing catching games</li> <li>• Asymmetric circuit</li> </ul>	<ul style="list-style-type: none"> <li>• Water Polo</li> <li>• Skills Games</li> </ul>	<ul style="list-style-type: none"> <li>• Gala</li> </ul>
<b>SAFETY</b>	<ul style="list-style-type: none"> <li>• Help position</li> <li>• Mushroom float</li> <li>• Huddle</li> <li>• Clothes float</li> </ul>	<ul style="list-style-type: none"> <li>• Talk rescue</li> <li>• Safety</li> <li>• Land based tow</li> <li>• Streamlined</li> <li>• Swimming in clothes</li> </ul>	<ul style="list-style-type: none"> <li>• Surface dive</li> <li>• Inverted breast stroke</li> <li>• Open water safety code</li> </ul>	<ul style="list-style-type: none"> <li>• Treading water</li> <li>• Side stroke</li> <li>• Help sign</li> </ul>	<ul style="list-style-type: none"> <li>• Land based rescue</li> <li>• Talk rescue</li> <li>• Reach rescue</li> <li>• Group systematic pool search</li> </ul>	<ul style="list-style-type: none"> <li>• Log book notes</li> </ul>



# Pre Aquatics Planning Session

- LEARNING OUTCOMES**
- *To motivate the students.*
  - *To agree rules for swimming sessions.*

**EQUIPMENT** *Labels, flip chart / black board, marker.*

**CLASS ORGANISATION** *Discussion format circle.*

## ACTIVITY ONE

### *Icebreaker / Labels Game*

1. *Each student has a label. Try and find your partner as fast as you can with matching label.*
2. *With partner, brainstorm your fears / expectations / hopes of swimming programme.*
3. *In group, record these on a flipchart.*
4. *Each pair link up with another pair.*

*Decide on three rules that you might put in place to address people's fears and would help ensure that their expectations are met.*

5. *In large group, record feedback.  
Do not repeat but tick a rule if a second group has identified it.*
6. *Nominate the top six rules. Take a class vote. Have a student type them out and each student can be asked to sign a copy. Include in folder.  
(A contract between teacher and students).*
7. *Give students a brief outline of course to be followed.*



## Unit 1: Floatation

### LEARNING OUTCOMES

- The student will:**
- experience methods of floatation through a series of activities
  - learn the principles of floatation
  - will show an awareness that correct body action contributes to improved floatation through the activities.

### EQUIPMENT

Floats, clothes, flotation objects.

## ENTRIES

- Ways to enter pool and stay head up in water
- Slip in
- Twist and slip in (swivel entry)
- Straddle entry

A swivel entry for the apprehensive student.

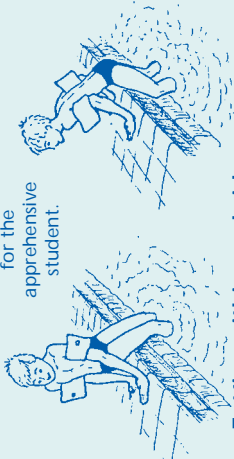

### Entries within pool side

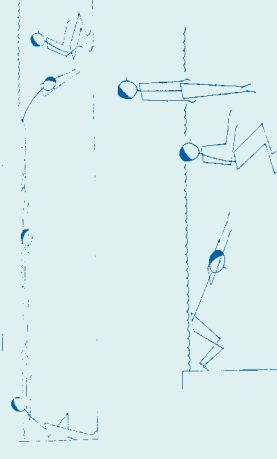

### Straddle jump

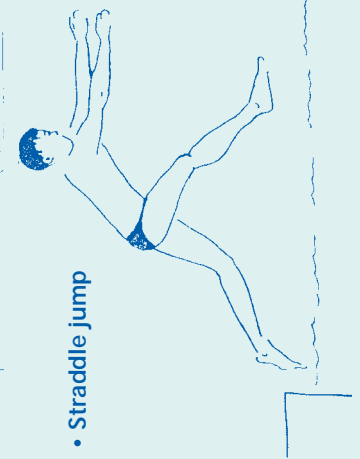

## STROKE

- Breathing head position will influence floating look up legs sink, look to side
- Push 'n glide using float (note distance)
- Push 'n glide without float
- Push 'n glide off wall on back (note distance)
- Float — fill up lungs with air
- Float empty lungs (note difference)
- Mushroom float
- Vertical float - what happens?
- Kick flutter (water can be used as resistance)
- Treading water
- Sculling - head first, feet first, stationary
- 'Sit' on bottom
- Lie on bottom - front and back
- Vertical breast stroke arm action especially useful for resistance training (legs off bottom in a cross legged position)
- Float and make the shapes X, I, Y, T
- Cross pool arms only (front crawl and back crawl)
- Repeat with leg action, note floatation effect

## GAMES

- Flotation aids
  - how is it best to hold aid?
  - what will keep you up?
    - balls
    - floats
    - ring buoys
    - can buoys
    - pull buoys
    - tubes
    - empty plastic containers
    - adapt to relay race game
- Game of floating tag - one identified catcher when caught must float (hold side if unable) to release, surface dive under
- Flotation circle - go prone to supine to prone (use of floats if people unable to float)
- Holding breath - how long can you float & hold breath in floating position
- Jellyfish float - go into "mushroom float" and then release arms
- What letters can you make with your body and still float
- Using your body, make a series of shapes X, I, Y, T,

## SAFETY

- If unable to float – due to bone and muscle density – use mushroom float
- Try to maintain "mushroom float" on bottom
- Recap on **H.E.L.P.** position must use a buoyancy aid
- **Use clothes to make aid**
- **Shirt**
  - Take off the shirt.
  - Tie a knot in each sleeve.
  - Tie top button around neck backwards.
  - Lift ends, hold behind back and bang down to gather air.
- **Trousers**
  - Take off trousers and tie a knot at the end of each leg.
  - Gather the waist and blow into it to fill with air.
  - Or gather waist and bang down into water.

## Unit 2: Streamlining

### LEARNING OUTCOMES

### The student will:

- explore streamline and non-streamlined movement in water through a series of activities.

### EQUIPMENT

Floats, water polo ball, clothes.

## ENTRIES

### Jumps

- Enter water with big splash/ with little splash
- Shapes in the air.
- Enter with or without streamline position
- Dives – sitting, kneeling, standing

### Entries/Turns

- Streamline push off for back crawl

- Streamline & somersault

- Freestyle to backstroke turn

## STROKE

1. Push & glide in a prone position.
2. Push, glide, kick, breathing effectively to either side.
3. Explore front crawl kick only with:
  - legs well apart
  - legs together
4. Breast stroke leg kick.
  - Emphasise on glide phase (see Breast Stroke card)
5. Breast stroke arm action with front crawl leg action.
6. Push glide; kick back crawl
  - legs together
  - legs apart
7. Back crawl leg action while rolling shoulders alternatively.
8. Back crawl push, glide kick, arms stretches over head.
9. Back crawl leg kick with float
  - at chest
  - behind head
  - close in at each side
10. One arm streamline kick. (see below)

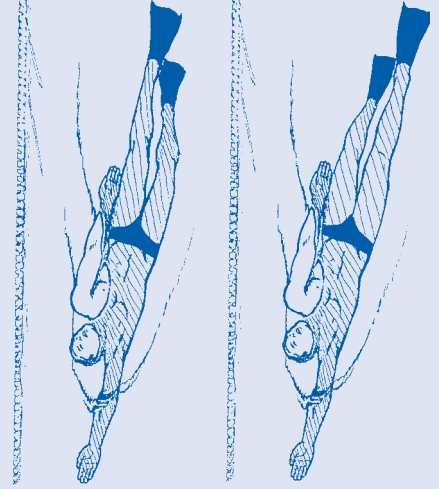

## GAMES

- Swimming in clothes (baggy shorts etc)
- Swimming outside the body line
- Water polo dribbling with attention to streamlined movements
- Push & glide under water (note distance gained)
- Push, glide under water with
  - arms streamlined
  - arms outstretched
- Sculling – feet first – head first
- Towing in the shallow end
- Silent swimming competition
- Cross pool using four different streamline positions
- Repeat above, matching with partner



- Partner
  - play with streamline
  - non-streamlined positions
- Use of aid, essential

- Assisted tow



## SAFETY

- Talk rescue
- Subject in apparent difficulty
- Rescuer lies prone on bank
  - reassures, talks subject to the side
  - encourages effective and efficient swimming
- Swimming in clothes
- To identify difficulties in streamlining
  - drag
  - tiredness.

## Unit 3: Symmetry

### LEARNING OUTCOMES

### The student will:

- experience symmetrical movements in and out of the water, through a series of tasks.

### EQUIPMENT

Level 1 circuit cards.

## ENTRIES

- Pike jump
- Straight jump
- Plain header
- Tuck jump
- Racing dive
- Star jump
- Crouch dive
- Other

## STROKE

- Bunny swimming
  - arms paddle together under the water
  - legs kick together
  - emphasise symmetry
- Dolphin kick (use float if necessary)
  - kick legs at same time
  - keep ankles loose
  - stretch toes
  - legs close together
- Breastroke legs (see resource material)
  - kick legs at same time
  - kick your bottom with your heels
  - turn your feet out
  - kick like a frog
- Breastroke
  - arms move at same time
  - arms move at same level
  - legs move at same level
  - legs move at same time
- Butterfly
  - arms move together over the water
  - body moves in undulating way
  - symmetrical movement
  - move like a wave in the ocean
- Double arm backstroke
  - symmetrical arm & leg action
  - arms leave the water together
  - kick both legs together from hips

## GAMES

- Aqua circuit
- Jump jacks
- Star jumps
- Volleyball blocks
- Tuck jumps (See Level 1)

## SAFETY

- **Surface dive**
  - breastroke action
  - tuck chin to chest
  - bend body at waist
  - lift legs simultaneously out of water
- **Inverted breaststroke legs**
  - keep knees close together
  - kick both legs at same time
  - turn feet outwards
  - draw a circle with heels (See resource sheet pg. 132)
- **Open water safety rules**
  - swim under supervision
  - swim parallel to shore
  - no longer than 20 mins
  - acclimatise to temperature of water slowly

## Unit 4: Asymmetry

### LEARNING OUTCOMES

- The student will:**
- experience asymmetrical movements in and out of the water, through a series of tasks.

### EQUIPMENT

### CLASS ORGANISATION

## ENTRIES

- Shore entry
- Sideways, step slide  
– lean towards shore (entry into unknown waters)
- Straddle jump
- Jumps using asymmetrical shapes
- Sitting on side, turning body to enter water
- Getting out of water at pool side

## STROKE

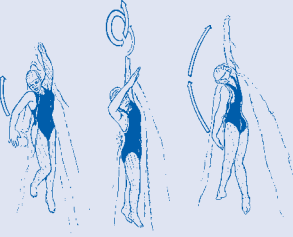

- Full F.C. stroke concentrating on number of strokes
- Front crawl catch up arm action
- Corkscrew swimming

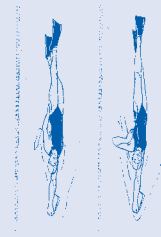

- Zip-up  
- High elbow recovery
- Trail fingers to extended position
- Pull

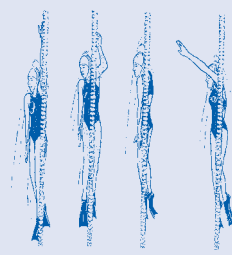

- Backstroke**
- Controlled one arm backstroke using pool rope to guide arm action

## GAMES

- Throwing & catching in pairs
- File relay
- Small sided throwing games
- Tucked position in water, turning in a circle using opposing sculling action
- Swim half width, turn, and swim on
- Races carrying the bucket

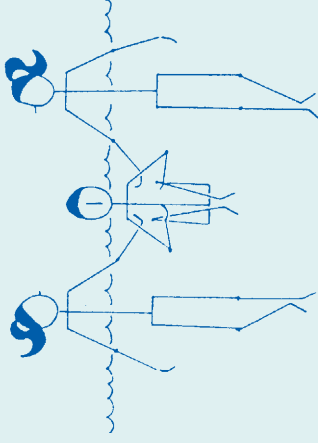

- Swimming with a ball & walking
- Shooting practices for Water Polo

### Circuit based on Asymmetrical

- Movements
- Dribble relay
- Partner passing
- Pool jogging/walking
- Woggle paddle (foam tubing travel around pool)

## SAFETY

- Side stroke
- Left side
- Right side (see Stroke Card)
- Treading water using "H.E.L.P.:" signal
- Ditto in shoulder depth water

Unit 5: group work in Aquatics

**LEARNING OUTCOMES**

- The student will:**
- experience a series of partner and group activities
  - co-operate with others
  - experience other challenging water activities: synchronised swimming, water polo, pool search.

**EQUIPMENT**

Poles, towels, buoys, balls, floats

**CLASS ORGANISATION**

**ENTRIES**

- In groups of 2, 3, 4
- Follow the leader
  - Match your partner
  - Contrast with your partner  
Use head first, feet first, turns, etc.

**STROKE**

- Syncho Swimming Practice**
- Practise any stroke breathing at the same time as your partner
  - Same side as your partner
  - Swim breaststroke towards your partner timing the breathing
  - Groups of three or more
    - follow the leader strokes
    - teacher as leader
    - student as leader
  - Group sculling
    - start in pairs
    - work towards large group, sculling feet first, legs first
    - experiment with changing shape bent knee, leg straight, one arm, etc.
  - Kicking with float on front / back
  - Synchronised arm actions
    - walking, standing, jumping, swimming
  - Routines for synchronised swimming. Sequence can include stroke, entry and aqua aerobic activities. Limit length to 5 movements.

**NB**

Aquatics is more than stroke swimming

**GAMES**

- Partner Tag**  
One partner chases another. Reverse roles.
- Water Polo**
- Dribbling technique
  - Throwing / catching
  - Shooting
  - Game format
  - Modified game format

**SAFETY**

- Rescuer**  
Focus on:
- Eye contact
  - Voice contact, reassuring and directing swimmer in difficulty
  - No bodily contact
- Subject**
- Follow instructions
  - Simulate the situation as outlined
- Group Pool Search**
- Systematic search of pool
  - Experiment first
  - Set formation

## Unit 6: Gala

### LESSON

### EQUIPMENT

### OBJECTIVES

- The student will:
- demonstrate one entry, and one stroke of their own choice up to a distance of 25 metres
- participate in a fun gala.

### CLASS ORGANISATION

## ENTRIES

Students choose one entry to demonstrate for assessment.

## STROKE

Students choose one stroke to demonstrate:

- appropriate arm / leg action
  - correct breathing technique
  - ability to swim distance.
- Attempt up to 25 metres.

Possible strokes to perform:

- breast stroke
- inverted breast stroke
- front crawl
- side stroke
- butterfly
- back crawl

## GAMES

### Gala.

See resource material for ideas.

## SAFETY

Log book submission

ENTRIES

• Breast stroke finish

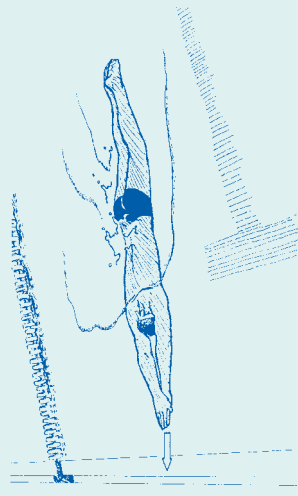
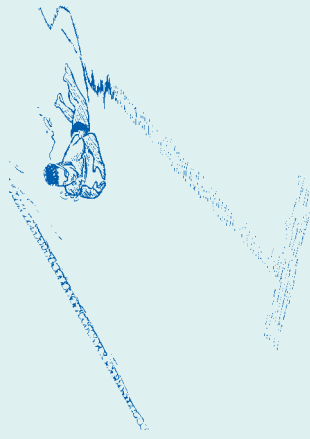

• Push off start from wall front crawl start



• Freestyle start from dive

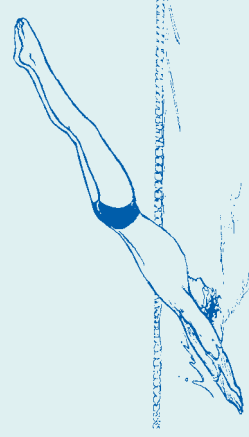
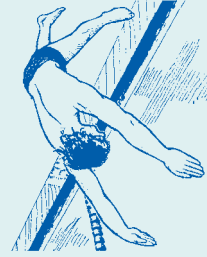
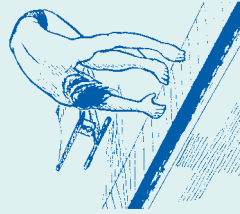

• Foot touch

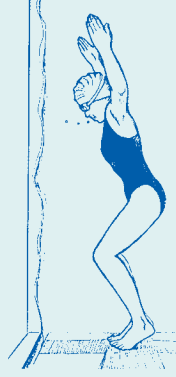
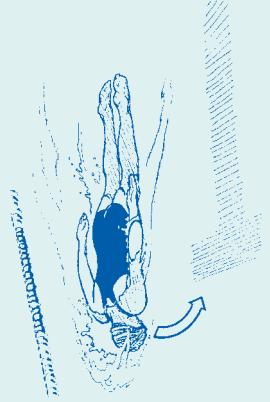

ENTRIES

Resource material: Unit 2

• Streamline push off for back crawl

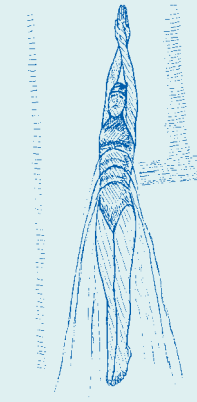
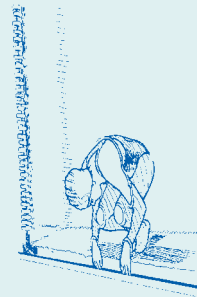

• Streamline & somersault

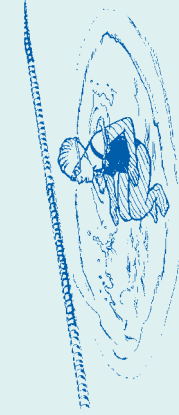
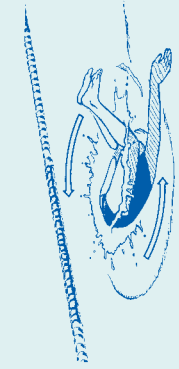
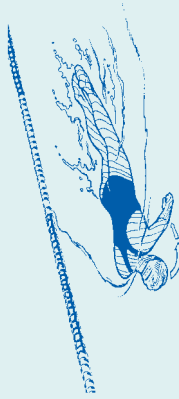

• Freestyle to backstroke turn

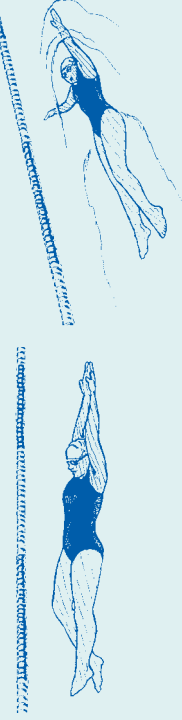
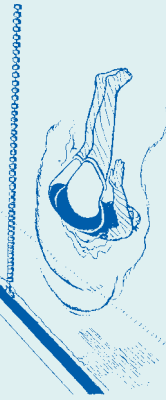



Resource material: Water Polo

**ACTION**

**Dribbling Action**

**Drills**

- File relay
- Time width

**Passing**

**Throwing**

**Pass 'n Go**

**Circle Passing**

**Piggy in the Middle**

**Game**

**Alternatives**

**POINTS TO NOTE**

- Ball may not be submerged.
- Ball is kept between two arms. Head up, front crawl with shorter arm action.
- One arm only to catch and throw.
- Cannot submerge the ball.
- Egg beater kick in treading is very effective especially for advanced swimmers.
- Teams start and restart at their own goal end.
- Ball is dropped in middle of pool.
- No tackling.
- Advanced swimmers cannot stand, hold side of pool.
- Modify rules to suit ability.
- Record heart rate!

- Place 20 floats / 20 arm bands / floating objects in centre of pool.

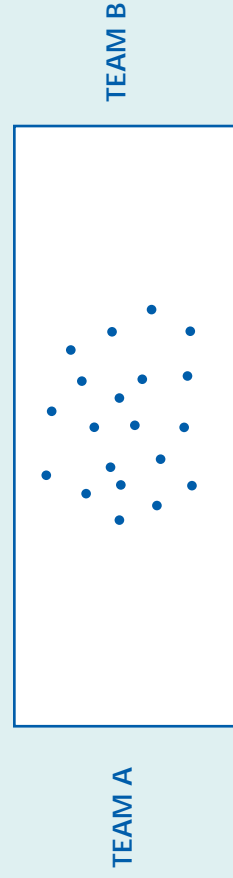

- Team discuss tactics to collect as many as possible.

Resource material: systematic search pattern task card

This technique allows a group to cover an area of water more quickly and effectively than one or two. They must work together under the firm command of leader, who gives signals and directions.

**SHALLOW WATER**

Students link arms and go across pool. Search with foot sweep.

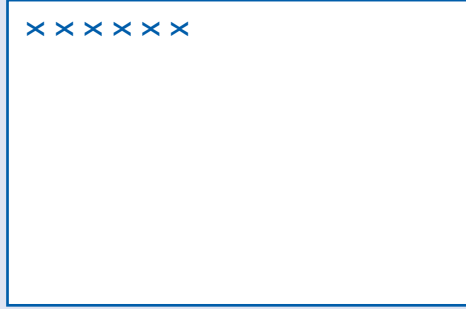

**CHEST DEEP**

Students in a line link arms. Search with feet. Transverse the pool.

Using a bobbing action, "duck" down and search area using feet and eyes.

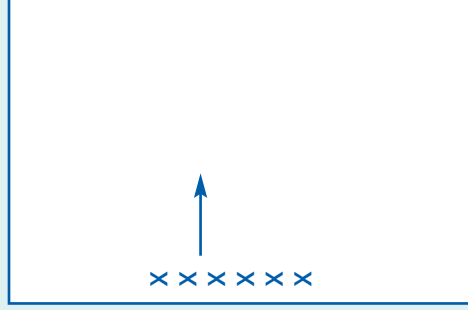

**DEEP WATER**

Students in straight line no more than arms length apart.

Dive and swim along bottom for a predetermined number of strokes, then surface.

Line reforms at the position of the shortest swim.

Leader calls the next dive when line has reformed. Repeat.

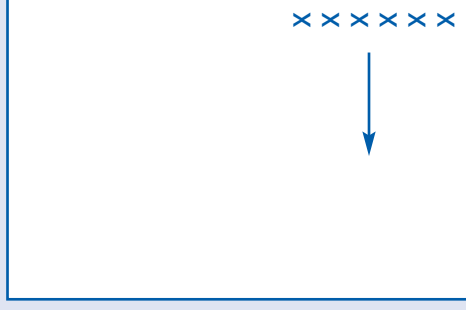

- THIS CAN BE ADAPTED
- Time exercise for search
  - Place objects in pool (time this)
  - Money is great incentive for searching!
  - Teams could compete under the same conditions.

## TANDEM GAMES

- Front person uses arm action
- Back person uses leg action

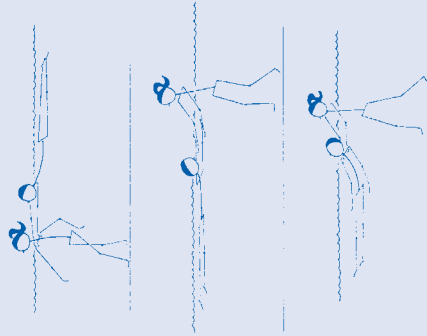

## SLIDING THE PLANK

- Both swimmers take up floating position, one behind the other.
- Person A in front reaches overhead to grasp the ankles of his/her partner.
- Moving under the water, person A pulls, pushes him/her along the surface to change positions.
- Person being pulled assists by sculling feet first.
- Several changes of position can be attempted.

## MIRROR SWIMMING

Partners attempt to mirror each other exactly.

## MEETING & PARTING

- Push from opposite sides of the pool, swim under water to meet half way across, then surface together.
- Approach from a distance, meet with a surface dive and rise together.

## PASSING IN TWO'S

- Deep water
- Shallow water
- Two handed pass
- One handed pass

## OVER & UNDER

- Shoulder depth of water, in pairs.
- Partner A stands feet astride, arm outstretched.
- Partner B surface dives over one arm, swings between partner's legs and repeats on the other side.
- Partners then switch over roles.
- This can become competitive.

## TOWING

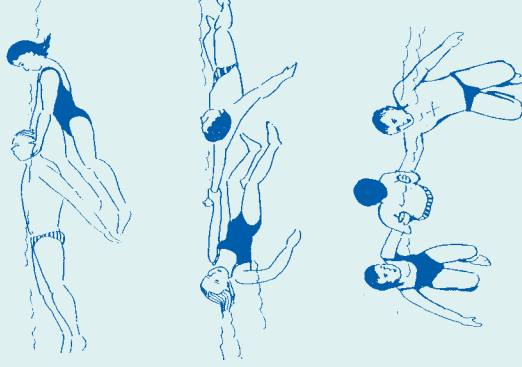

- More experienced swimmers only!
- Experiment with towing each other using rope, hoop, float etc.
- Difficult strokes may be used and the activity can be competitive over stated distances.

## CHINESE WALL

- All swimmers at one side of the pool – deep or shallow water, depending on student ability.
- One person is chosen to occupy the centre of the pool.
- Swimmers attempt to cross pool without being caught.
- If caught, join centre person to act as catcher.

## TEN TRIPS

- Teams of four.
- Ball is with the person at the front of the line.
- Ball is passed over the heads of the team.
- Back person swims up to front and repeats.
- First team to repeat X number of repetitions.

Variation:  
Over the heads, under the legs.

**EQUIPMENT**  
Clothes, egg and spoon, balloons

**CLASS ORGANISATION**

Event No	Description
	Beginners race - one width any stroke (boards)
	Freestyle race - one length
	Breaststroke - one length
	Backstroke - one length
	Sculling race - one length
	Tandem race - one length
	Towing race - half length <small>Partner swims width with a rope. Team pulls him / her back.</small>
	Wheelbarrow race - half length
	Medley team race - half length (any style)
	"Egg & spoon" race - one width / relay
	Clothes race - swim/run race, disrobe in middle of pool — Swim / run to side.
	Balloon race - blow to the other side
	Ping pong ball race

Event No	Description
	Plastic cup & saucer race - swim collect full cup & saucer — swim / run back (keep cup full)
	Over & under race - ball passed over/under
	Obstacle race (ropes, hoops)
	Butterfly race - one length
	Demonstrate – surface dives – spinning – jumps
	Soccer/volley match – use hands instead of feet – use sinkable "ball" (mind toes)
	Water polo game
	Basketball

Resource material: Sculling

- USES**
- 1 Propel over weeds without risk of entanglement
  - 2 Propel oneself even if a leg injury has been sustained
  - 3 Synchronised swimming
  - 4 Water polo

**TYPES**

Head first  
Feet first  
Stationary

**Body Position**

- Head is still
- Ears submerged
- Eyes looking forward
- Body as near to horizontal as possible
- As near to water surface as possible

**Arm Action**

- Continuous
- Level with buttocks
- Close to side
- Arms straight
- Fingers together
- Palms almost flat

**Outward Sweep**

- Little finger is uppermost

**Inward Sweep**

- The thumb is uppermost

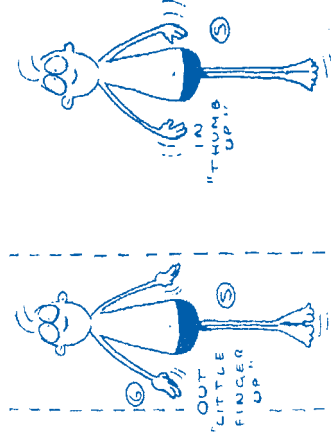

**Stationary skull**

Fingers parallel to water surface



**Head first skull**

Thumb uppermost

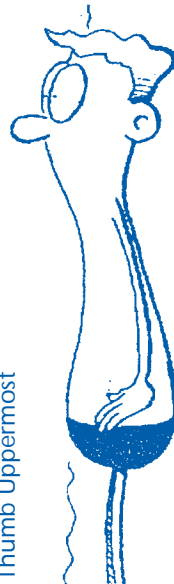

**Feet first skull**

Little finger uppermost

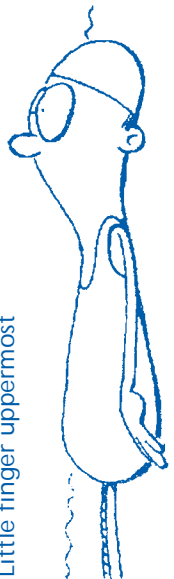

**Practises**

**Arm Action**

- Standing in shoulder depth water practise arm action
- Wearing a buoyancy aid, practise arm action
- With feet under rail, in supine position practise the arm action
- Hold the float across chest practise with other hand - swap sides

**Timed Sculling Practises**

- Sculling in a vertical position — no leg action
- Raise chest out of water for varying lengths of time
- Horizontal position, skull carrying a brick on your stomach
- Horizontal position, tow someone by hooking feet under arm pits
- Partner makes no propulsive movements
- Only possible using a head first sculling

Resource material: Breast stroke

**Body Position**

- Keep head still
- Keep your shoulders level
- Keep hips slightly lower than your shoulders
- Keep your hips level

**Leg Action**

- Kick both legs at same time
- Kick heels towards buttocks
- Knees close together under water surface
- Kick like a frog
- Make sure your feet meet at end of kick as your legs are fully stretched
- Turn feet out sideways
- Kick back and around powerfully
- Make a D shape with both legs "D"

**Arm Action**

- Move your arms at same time
- Insweep, outsweep, recovery (see diagram)
- Draw an upside down shape with the arm action

**Breathing Action**

- Breathe in as you are finished pulling and out as you stretch forward
- Pull arms, then breathe, kick and finally stretch

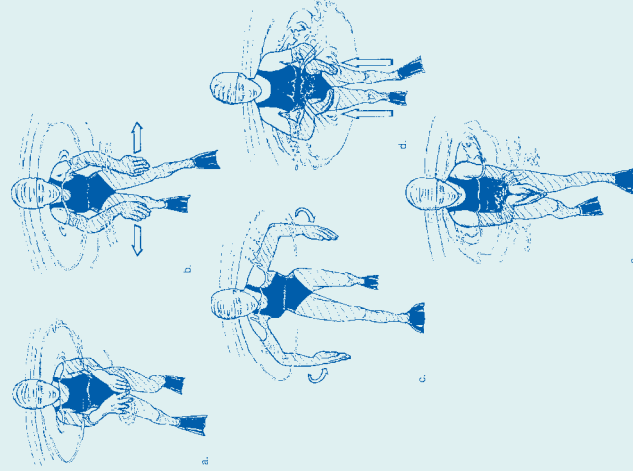
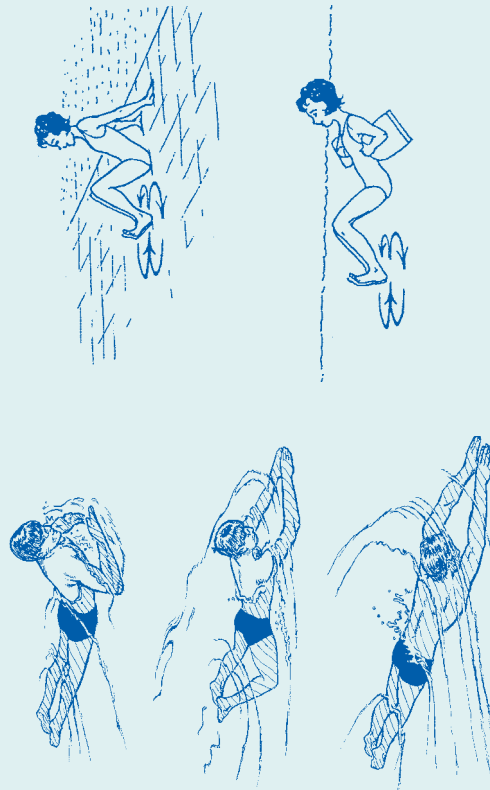

**Body position**

- Standing static slowly submerge face to brow level
- Holding rail extend arms and legs, face to brow level
- Floating face to brow level lift chin forward (breathing practice)

**Leg action**

- On the side of the pool
- On the back using 2 floats
- At the rail elbows pressed against wall
- Using two floats knuckles together chin in water
- Legs only, no float, on your back/ on your front
- Count kicks using board over specified distance try to reduce number of kicks

**Arm action**

- Practice standing submerged at shoulder depth, copy teacher demonstrating
- Walk and use arm action
- Bunny hop & 2 arm actions (any leg kick)
- Use of arms with float between legs (use to learn breathing also)

**Breathing action**

- Standing exhale into water
- Push chin forward to inhale
- Arm action & breathing
- Push glide, pull breath & stand, repeat then don't stand
- Push, glide, pull, breathe kick & glide
- Build up a number of repetitions

**Co-ordination practices**

- Arms and legs action hold breath try to do up to 5 strokes
- Arms and breathing float between legs - to get timing & breathing
- Leg action and holding float breathing
- "Arms out", "legs in", breathe in
- Arms in legs out breathe out.
- Two kicks, one pull. Focus on glide.

Resource material: Breast stroke/sidestroke

## INVERTED BREAST STROKE

### Body Position

- Streamlined on back
- Upper body stable
- Head above water



Recover the arms close to the body.

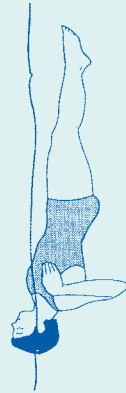

### Leg Action

- Begin with legs together and toes pointed
- Bring legs in towards body
- Make a circle with the heels
- Squeeze the water with the lower legs
- Make a double D- one with each leg
- Keep knees close together throughout

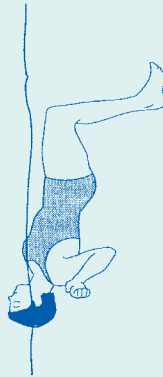

Recover the legs and move the arms to a 'Y' position. Breathe in during this recovery phase.



Pull, kick and breathe out.

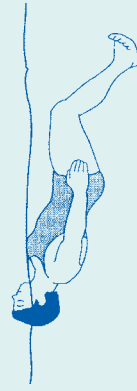

### Arm Action

- Arms may be held by the sides or over the head or across the chest
- One float may be used in both hands or one in each hand with arms resting on the float and grip over the end

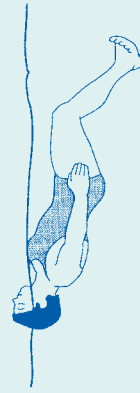

Glide.

## SIDESTROKE

### Body Position

- Streamlined on right or left side



### Leg Action

- Upper leg moves backwards, lower leg moves forward
- A quick scissors movement brings the legs together to provide propulsion
- Similar to breaststroke legs but done on the side

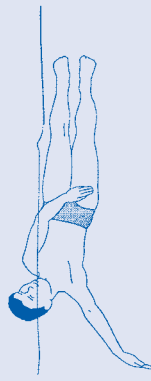

Pull with the lower arm, recover the upper arm and the legs and breathe in.

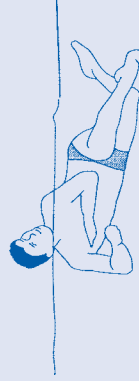

### Arm Action

- Arm pull is shallow
- Leading arm pulls to meet trailing arm which then pushes
- "Pick apple from tree" with leading arm "pass it to other hand which puts it in the basket"
- Arms remain in the water

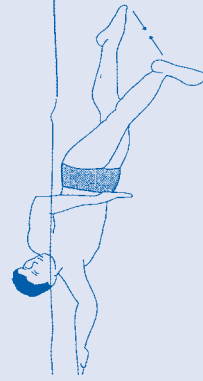

Stretch the lower arm, push back with the upper arm and scissor the legs.



Glide and breathe out.

## Resource material: Butterfly

### Body Position

- Head still and in middle
- Top of head leads
- Dolphin action
- Wave action
- Keep body loose
- Mermaid like

### Leg Action

- Kick both legs together
- Legs kicked continuously
- Ankles loose
- Stretch toes away
- Kick from tummy and buttocks

### Arm Action

- Both arms together
- Hand in water in line with shoulder
- Thumbs in first
- Fingers together palms flat
- Hands trace shape of keyhole, underwater
- Hands push back as far as thighs
- Arms go wide and low over water
- Flying position out of water

### Breathing

- Push chin forward, breath every 2 pulls
- Face in as arms come over water
- Blow out hard as chin comes out

### Co-ordination

- Kick hard as your hands go in and as hands go under your tummy

Introduce arms.

From the rail.

Followed by legs only.

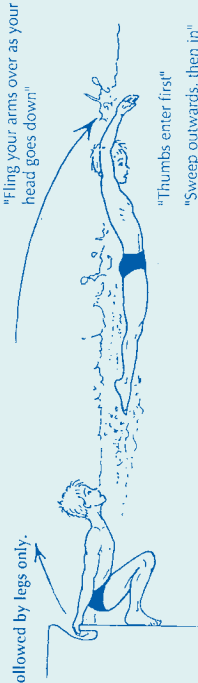

Full stroke.

No breathing.

Emphasise arms.



Introduce breathing.

At the rail.

"Chin on your chest. Blow out hard."

"Chin up. Breathe in"



Full stroke.

Breathing every second stroke.

"Blow your hands out of the water"

"Kick your hands into the water... Kick hands out of the water"



### Practices

- Legs only arms on rail
- Legs only head in water arms by side
- Legs only thumbs linked
- Legs only along bottom thumbs linked
- Legs only on side
- Legs only on back

### Practices

- Arms only static practice
- Arms only walking
- Push, glide, pull, 2 arms 2 shoulders
- Arms only board between legs

### Practices

- Static chin forward
- Static chin & arm action
- Walking arm action
  - breathing in arms back
  - out arms forward



- Running
- Jumping
- Throwing
- Baton Changing
- Team Competitions
- Relay Activities

# Athletics

*running jumping  
throwing competitions  
baton changing games  
competitions*



# CONTENTS



	<i>Page</i>
<i>Overall Aim and Objectives</i> .....	<b>138</b>
<i>Teacher Guidelines</i> .....	<b>139</b>
<i>Level One</i> .....	<b>141</b>
<i>Learning Outcomes</i> .....	<b>142</b>
<i>Content Framework</i> .....	<b>143</b>
<i>Units</i> .....	<b>144</b>
<i>Resource Material</i> .....	<b>150</b>
<i>Level Two</i> .....	<b>157</b>
<i>Learning Outcomes</i> .....	<b>158</b>
<i>Content Framework</i> .....	<b>159</b>
<i>Units</i> .....	<b>160</b>
<i>Resource Material</i> .....	<b>166</b>

# Overall Aim & Objectives

## **AIM**

To provide the students with the opportunity to develop personally, socially and physically through participation in a variety of athletic activities in a safe and enjoyable environment.

## **OBJECTIVES**

- *To provide opportunities for participation in running, jumping and throwing activities in a variety of contexts.*
- *To enhance knowledge and understanding of athletic activities.*
- *To encourage personal goal setting and an understanding and appreciation of the concept of fair play through enjoyable participation in athletic activities.*
- *To develop a more advanced technique in specific activities.*



# Teacher Guidelines

## **SAFETY**

Throughout the athletics programme safety is of paramount importance. Environment, equipment, methodology, content and students' level of expertise are all important factors in this area. In general, all athletic lessons must be 'user friendly' and involve the maximum number of students for the time allocated.

Athletics is a sport in which a variety of running, jumping and throwing activities may be taking place at the same time. It is essential therefore, to maintain an awareness of this and to plan the layout of practices with this in mind. The safety of participants is the major concern.

- *All equipment should be kept in good repair and stored in a safe place.*
- *All sessions should start with a warm up and finish with a cool down.*
- *Outdoor running areas should be level and free of potholes, glass etc.*
- *Students must wear appropriate footwear.*

## **SAFETY AWARENESS FOR THROWING ACTIVITIES**

- While learning and practising throwing activities can be exciting for the student, the teacher must be aware of the inherent potential dangers.
- Discipline must be developed from the first lesson. Implements should be carried to and from the throwing area and not used outside of the session itself.
- Implements must be chosen for lesson, of a weight and size appropriate to the strength, age and hand size of the participant.
- Other students should be cautioned not to trespass into the throwing area.
- It is essential that students not only throw on the orders of the teacher but also collect only on the orders of the teacher.
- Each athlete must be taught to check to see that nobody is standing in the throwing area / sector before throwing. Athletes should be taught to spot for one another during the lesson.
- All those waiting to throw, spectators or bystanders must stand well clear of the throwing area.
- Only when everybody has taken their throw should students be allowed to collect the implements from the throwing area.

## **SAFETY AWARENESS FOR LONG JUMP**

- Do not allow students jump into an undug pit.
- The sand in the pit should be fine, well raked, level and a little wet to avoid dust.
- It should be deep enough to avoid jarring on landing (minimum 30 - 40cm).
- The sand should be clear of all debris (glass, stones, sticks, etc.).
- The edges should be designed so the athlete will not get injured if they fall to the side/front.
- The pit should be away from throwing areas.
- Rakes and shovels should be positioned away from landing area.
- The take-off board should be firmly fixed to the ground and be flush with the surface of the run-up.
- The run-up should be firm, level and any depressions in ground (particularly near take off board) should be filled in.

### ***WARM UP AND COOL DOWN***

It is suggested that all classes must start with a warm-up and end with a cool-down.

- *Build up gradually from small to greater efforts.*
- *Start with whole body and progress to muscle groups most directly concerned with the activity.*
- *Include stretching and mobility exercises as part of the warm-up.*

### ***GENERAL TO SPECIFIC***

It is suggested that all classes/blocks of work should go from the general to the specific.

### ***ENJOYMENT***

In each lesson the student should be exposed to fun/enjoyable activities through a variety of learning experiences.

### ***BALANCE***

Within every athletics lesson the teacher should endeavour to have a balance between a variety of physical activities and necessary teacher instruction / student discussion. The technical aspect of specific events should not dominate the lesson at the expense of student participation.

### ***METHODOLOGY***

While accepting that each teacher has his/her own method of teaching the various athletic activities it is suggested that cognisance be taken of the various teaching methodologies. In the units in the following section specific methodologies are suggested which include working in large/small groups; pairs; individual; teacher / student demonstrations; 'Whole-part-Whole' methods. The content of the lesson may dictate the methodology to be used within each lesson.



# Athletics



Level  
One

# LEARNING OUTCOMES

*The student will:*

- *be able to run at a steady pace suitable to his/her level of fitness for a set length of time*
- *enhance his/her ability to jump for distance*
- *improve his/her ability to throw for distance using a variety of implements*
- *develop an understanding of the principles in relation to running for speed and running for distance, (i.e. pace)*
- *be aware of the safety factors associated with athletics when participating and also when handling and using equipment*
- *improve their knowledge of relay running and enhance their ability to pass the baton*
- *be able to take their own pulse*
- *develop an appreciation of athletics.*





# CONTENT FRAMEWORK

## CONTENT SELECTION

Warmup activities should be related to the specific content of the lesson and should follow the principle of *general to specific*.

### UNIT 1: RUNNING

Reaction  
Running drills and standing start  
Activities for speed  
Relays (sports hall type)



### UNIT 2: RUNNING AND JUMPING

Endurance activities / Bleep test  
Relate to health and fitness (pulse/recovery)  
Speed bounce (20 secs +)  
Jumping drills and games/competition

### UNIT 3: RUNNING AND JUMPING

Relays  
Standing long jump  
One step standing long jump onto mats  
Standing vertical jump  
One step vertical jump  
Games to cover jumping activities



### UNIT 4: RUNNING AND JUMPING

Jump drills  
Standing triple jump - rhythm  
Introduce technique of baton changing 'down technique'  
Relays

### UNIT 5: THROWING AND RUNNING

Introduction to standing shot putt  
Throwing from standing/sitting positions  
Variety of implements  
Games/competition for throwing



### UNIT 6: CLASS COMPETITION

Competition involving running/throwing/jumping  
Evaluation of running/throwing/ jumping  
(re progress, understanding and learning)  
Groups of 4/6 - complete class involvement  
Team challenge ( sports hall type activities)

## INTEGRATION

Possible opportunities within each lesson for integration with health related activities e.g.

- pulse rate and recovery
- endurance
- elastic strength

Unit 1: Running

**LEARNING OUTCOMES**

- The student will:**
- develop an understanding of the principles relating to running for speed
  - demonstrate the correct technique of a standing start
  - demonstrate correct running technique
  - gain an understanding of the safety procedures associated with warm up and cool down activities.

**EQUIPMENT**

Whistle, cones, bean bags (20 / 30), hoops (4–6).

**CLASS ORGANISATION**

A large area is required, indoors or outdoors.

STAGE	CONTENT / ACTIVITY	TEACHING POINTS
Warm up	Build up gradually from light to greater effort. Aerobic activity followed by stretching is recommended. (see resource material for variations).	Explain importance of warm up to the student. Ensure all stretching exercises are performed correctly.
Development	<p>Game of tag with 2 people tagging, “Who can tag the most?”</p> <p>Change people tagging every 30 seconds.</p> <p>Practice: Running drills (See resource material.) e.g. Knee raising Heel flicks Bounding</p> <p>Speed drills reacting to different stimuli - whistle, clap, ‘go’, etc.</p> <p>Standing start.</p> <p>20m sprints, with correct ‘standing start’ reacting to different stimuli.</p>	<p>Helps introduce speed.</p> <p>Explain why 1 person may be faster than another. (Body type, age, clothing, equipment etc.)</p> <p>Look for correct techniques in each activity. Allow students work in pairs and help each other. Allow sufficient recovery time.</p> <p>Run over 10 metres – look at reactions.</p> <p>Allow sufficient recovery time between drills. Look for positioning of feet and arms.</p> <p>Position yourself away from students, getting them to focus on start.</p>
Conclusion / Cool down	Cool-down, including gentle stretching exercises.	<p>Ensure activities are performed correctly and outline importance of cool-down. Go back over main points and use questioning to assess student learning.</p> <p><b>Integration:</b> The possibility exists to link parts of the unit with health related activity material, e.g. flexibility, strength.</p>

## Unit 2: Running and jumping

### LEARNING OUTCOMES

- The student will:
- be able to run at a steady pace suitable to his/her level of fitness
  - enhance his/her ability to jump for distance and/or height through an understanding of jumping
  - gain an understanding of the safety procedures associated with running and jumping
  - be able to take his / her own pulse

### EQUIPMENT

Skipping ropes, mats, speed bounce mats.

### CLASS ORGANISATION

A large area is required inside/outdoor (min 30 x 20 metres).

STAGE	CONTENT / ACTIVITY	TEACHING POINTS
<b>Warm up &amp; Mobility</b>	<p>Take pulse before warm up begins. Build up from easy to greater effort. Use drills learned in Unit 1: running drills - 'run tall', 'high knees', 'heel flicks', 'relaxed shoulders', 'arm action', 'striding'. All drills should be aerobic in nature followed by stretching routine - 'Head to toe'.</p>	<p>Use 6 sec. / 10 sec. technique. Emphasise importance of warm up. Explain muscle groups being stretched. Explain aerobic / anaerobic (briefly). See resource material.</p>
<b>Development</b>	<p>Continuous 'easy' running for 30 secs - take pulse - whole group. Continuous moderate running for 60 secs - take pulse - whole group. Methods of developing endurance: Introduce: (a) speed bounce (b) skipping ropes (c) bench stepping for 30/40 secs. Introduce hopping/skipping drills. Use mats / grass. (a) Hopping right x 5 (b) Hopping left x 5 (c) Long steps x 5 (d) Combine hopping and stepping Competition on distance for: (a) 5 steps (b) Two hops, one step, two hops. (c) Shuttle relay(s) using hopping left/right on way out/back.</p>	<p>Note the increase in pulse rate in relation to effort and time. Get students to understand how to develop endurance, mention the F.I.T.T. Principle (Frequency, Intensity, Time, Type). Do 2 or 3 activities. Rhythm. Flat foot and use of arms (basics of bounding). Upright trunk. Right thigh / left arm. Place cones at 5 - 10 metres (1 metre apart). Do 2 or 3 activities. To incorporate skills learned into team competition.</p>
<b>Conclusion</b>	<p>Cool down - very easy jogging / walking. Stretch leg muscles.</p>	

Unit 3: Running & jumping

The student will:

- develop an understanding of the principles related to jumping for distance and height
- perform measurement of a number of activities.

LEARNING OUTCOMES

EQUIPMENT

Whistle, cones, mats, ropes, speed bounce mats, tape measure, pre-marked mat or floor.

CLASS ORGANISATION

It would be preferable to have a large indoor area for this class

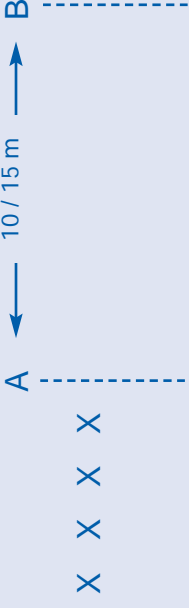
STAGE	CONTENT / ACTIVITY	TEACHING POINTS
Warm up	Aerobic warm up involving skipping. Go into stretching routine. Revise running drills. Do any relay from resource material.	Use questioning to assess students' understanding of warm up. Explain 'pace' and how it varies in different events.
Development	Revise drills from unit 2, (speed bounce, hopping and stepping drills etc.)  Introduce standing long jump Jump with hands above head Jump with hands by side Jump with hands swinging Introduce 1 Step Long Jump  Introduce Standing Vertical Jump Straight leg jump Bent leg drive - no arm action Drive with legs, swinging arms 1 step and jump  In groups of 4/6, allow students to measure and record standing broad jump and vertical jump.  <b>Game: Jump Relay</b> Groups of 4 or 6. Group with fewest jumps (2 footed) from one point to another.	Give sufficient recovery time between each activity.  Ensure students land with 2 feet together and bend at knee on impact, flat feet. Progressing to jump with step before jumping.  Look for upright trunk, good leg drive, keep head upright.  Ensure students land correctly. Ensure all students are involved in jumping, measuring or recording. (use premarked mats / floor). <div style="text-align: center;">  </div>
Conclusion	Cool down - Gentle jog/walk & stretching. Revision of what was learned in class.	Identify main muscle groups being stretched. Use questioning (can also be done during cool down phase).

Unit 4: Jumping & baton changing

**LEARNING OUTCOMES**

- The student will:
- perform a standing triple jump
  - outline the basic rules governing sprint relays
  - demonstrate correct technique of passing baton using down technique.

**EQUIPMENT**

Gymnastic mats, whistle cones/markers, batons.

**CLASS ORGANISATION**

An area of at least 30 x 20 metres, inside/outside.

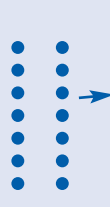
STAGE	CONTENT / ACTIVITY	TEACHING POINTS
Warm up	<p>Jogging, side skipping, jumping (one foot - land on two - for height). Co-ordinate arms with free leg. Class to stop every 30 secs to stretch quadriceps, hamstrings, lower back and shoulders plus body weight exercises such as press ups/sit up.</p> <p>Brief Q&amp;A on main points on Unit 3 - practise / demonstrate.</p>	<p>Very gentle warm up.</p> <p>Recap on main areas of Unit 3</p>
Development	<p>Introduce triple jump from a standing position - demonstrate full jump i.e., for a right footed student. Hop (right to right) Step (right to left).</p> <p>Class Activity (break the triple jump down into its component parts and practise).</p> <p>e.g., No 1 - Hop (walk back) (Stage 1)      <b>Repeat 3 / 5 times</b>                      No 2 - Hop (walk back)      <b>Repeat 3 / 5 times</b>                      No 1 - Hop &amp; Step (walk back) (Stage 2)                      No 2 - Hop &amp; Step (walk back)      <b>Repeat 3 / 5 times</b>                      No 1 Hop &amp; Step &amp; Jump (Stage 3)                      No 2 Hop &amp; Step &amp; Jump                      Hop, Step &amp; Jump to pre-determined lines/mark (3 / 5 times)</p> <p><b>BATON CHANGING</b>                      Introduce basics of 'down technique'.                      Having observed demonstration students perform skill in pairs / groups in stationary position, then walking, followed by passing while jogging (right to left, left to right).</p> <p>Students practise in straight line in pairs.                      Have a race in 4's, getting baton from start to finish, without being dropped.</p>	<p>Have class in pairs all facing one direction                      Surface-grass or gym mats</p>  <p>Teacher instructs                      Students help each other. Distance is not important                      Place marks 1.5m apart on floor. Look for rhythm i.e., to perform hop, step and jump of similar lengths.</p> <p>Receiving athlete puts hand back, palm facing upwards with fingers together, thumb out from fingers. Incoming runner passes baton 'down' into outstretched hand.</p> <p>Look for change with right / left, left / right.                      You may do this around a running track or in a straight line with short changing zones (see resource material-relay activities).</p> <p>Cannot throw baton. 'Change-over zone'.                      Staying in lanes. No interference with others.</p>
Conclusion/ Cool down	<p>Very easy jogging/walking for 2 minutes, followed by stretching of main muscle groups.</p> <p>Outline basic rules of relay running.</p>	



Unit 6: Running / throwing / jumping / jumping (class competition)

**LEARNING OUTCOMES**

- The student will:
- perform a throw from chin and behind head
- perform a standing long and standing triple jump
- change baton efficiently in relays
- score a simple sportshall competition
- perform a speed bounce test.

**EQUIPMENT**

Score cards/blackboard, bench, football, indoor shot or medicine ball (2kg), cones/reverser boards, gymnastic mats, 2 tapes, baton, speed bounce mats.

**CLASS ORGANISATION**

An area of at least 30x20 metres - inside/outside is required.

STAGE	CONTENT / ACTIVITY	TEACHING POINTS
Warm up	Walking, jogging in one direction around the 30x20m area - a stick baton between 2 - exchange baton drill - skip drill: stepping/hopping drills (see resource material).	Right to left hand Trail runner moves to front after delivering the baton
Development	<p>Students organise themselves in 4/5 teams - each group requires score card and pen (see resource material).</p> <p>Each team begins at one of the five stations</p> <ul style="list-style-type: none"> <li>• Standing long jump</li> <li>• Standing triple jump</li> <li>• Medicine ball throw / shot putt from neck</li> <li>• Seated football throw from behind head</li> <li>• Speed bounce</li> </ul> <p>All teams compete in relay(s).</p>	<p>Teacher will have floor / area pre-marked (see map of floor - resource material), and will have general score sheet (perhaps on blackboard).</p> <p>Briefly explain what is required at each station.</p> <p>Teacher moves each group to new station when each student has had his/her attempts.</p> <p>All measurements to accuracy of <math>\frac{1}{4}</math> metre.</p> <p>Teacher may choose one from resource materials.</p>
Conclusion	Overall scores are recorded onto a board.	

### WHY WARM UP?

The warm up is an essential part of physical activity, and an essential feature of any safe lesson.

A comprehensive warm up helps prepare the body and the mind for the exertions that are to follow.

It helps reduce the chance of injury by increasing the blood flow to the muscles and so allowing them to function more efficiently.

### GUIDELINES FOR A GOOD WARM UP

A good warm up can include:

- Easy jogging
- Stretching exercises
- Some practice drills/games related to the activity
- Games, e.g. chain-chase, stuck in-the-mud

The time lag between warm up and activity should be kept to a minimum. After the warm up keep directions brief and the students moving. e.g. jogging on the spot while you are talking to them.

Encourage students to take the initiative and start warming-up themselves while waiting for others or for the lesson to begin.

### WHY COOL DOWN?

- Reduces the heart rate gradually from the exertions of the activity.
- Prevents post exercise stiffness and soreness.
- Allows the body temperature to return to normal gradually.

Avail of the relaxation period at the end of the session to praise the students for their efforts, to clarify details about the next lesson and allow them make some suggestions about activities to start the next day.

### WARM UP AND STRETCH EXERCISES

'Warm up' and 'stretch' can be presented as a practical group activity involving discussion, demonstration and practice.

Warm up is to get our engines and working parts moving to provide efficiency and prevent breakdown.

Stretch exercises stretch our muscles to improve their flexibility range and prevent pulls. They also stretch our rib cage reducing resistance and improving our air intake.

Students like doing the exercises. It is a good habit to develop and can therefore be seen as a preventative activity.

- Keep the exercises simple and explain their purpose.
- Split the students into groups and call on each group in turn to remember an exercise. This makes a 'Round Robin' game and helps them to remember.
- In later lessons, appoint leaders to lead each group in warm up.

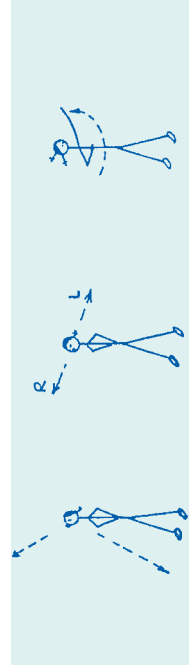

1. Look at the ceiling or sky. Look at the floor.
2. Look to the left. Look to the right.
3. Arm swinging

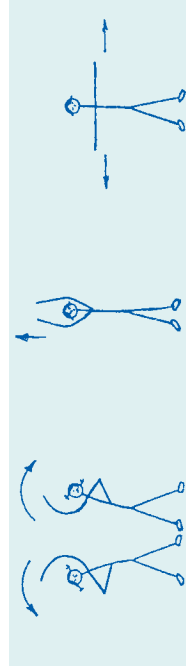

4. Trunk side to side. Keep one hand on .
5. Stretch to the heavens (bend knees slightly).
6. Arms outward. Stretch.

In both 5 and 6 when the student has stretched, ask them to try a little further.

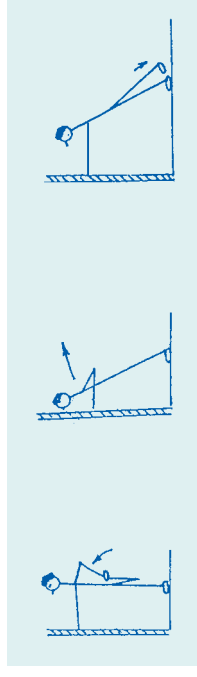

7. Quad press. Don't arch the back.
8. Wall press. Press to and from wall.
9. Achilles stretch. Keep one foot off the floor and press the other foot down until it is flat on the floor.

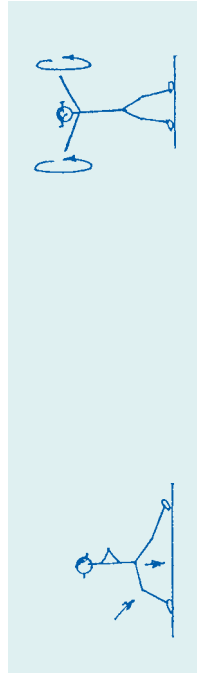

10. Pelvic stretch. NOTE: The front foot is in front of the knee.
11. Arms circling. Small circles and large circles. Forward and back or one arm circling forward and one circling backwards. Keep movement under control..

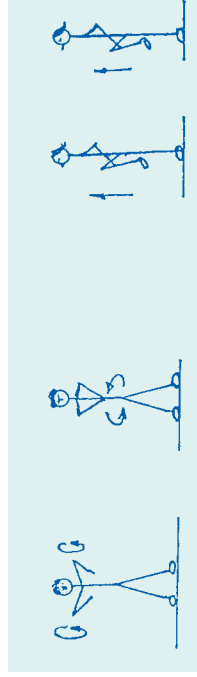

12. Shoulder Rolls
13. Hip Rolls
14. Knee raise and pull-up using hands. Assist the knee raise by pulling up with hands



## Resource material: Running drills

Repetitions: 2

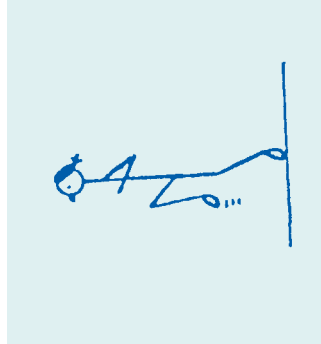

### A. KNEE RAISING

Exaggerated rapid knee raising, moving slowly forward, improves knee lift, style and stride. It is also important to pump arms backwards and forwards from your hips to your shoulders. Keep shoulders back, body upright, look forwards

Repetitions: 2

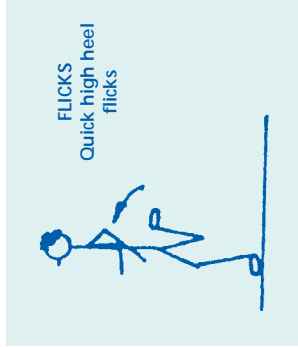

### D. FLICKS

Run forward slowly flicking your heels as high as you can as you bring your knee forward. If you observe sprinters you will notice the heel lifting high before following through to start the action. This compliments knee raising.

Repetitions: 6-8

### B. SPRINTS

(a) Short sprints with slow jog or walk back. By not allowing yourself to get out of breath, you are concentrating on speed. If you trot back to the start 'A' and get a little out of breath, stamina is involved (useful discussion topic).

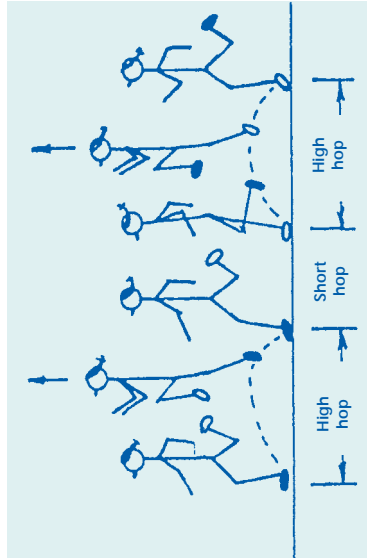

### C. LEAPS

Moving slowly forward hop as high as you can, lifting the knee of the free leg as high as possible - then take a short step so that you can hop off the other foot and raise the other knee. Developing foot drive is good for all events but is important for jumpers.

Repetitions: 2-3

Repetitions: 2-3

### E. BOUNDING

A series of long bounds stretching the pelvis. Later in the course try to exaggerate the bound with increase knee and heel lift.

Other activities such as hopping, left and right footed and sideways striding facing left and right can be included.

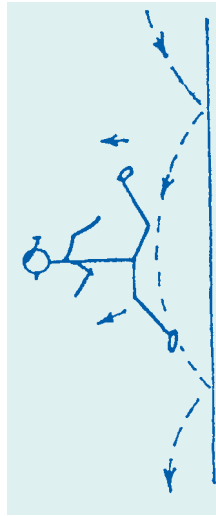

### F. STRIDING

Maximum running stride, without losing form.

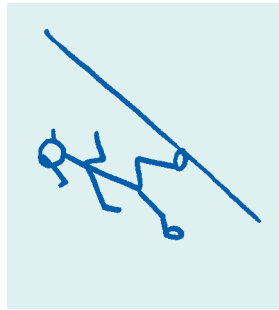

### STANDING START

This start is generally used by middle and long distance runners, but can also be used by younger athletes for sprint races.

### METHOD:

When students hear 'on your marks', they should place most of their weight on their front foot and lean forwards in a comfortable position, over the line. Be up on toes on back foot.

Have hands slightly relaxed. Opposite hand to leading foot, the other slightly behind.

On 'go', push off fast. You will notice that students will take a slight step back with the front foot as they react to 'go'. There is no need for 'set' with this start.

Resource material: Aerobic / anaerobic endurance

## Aerobic Endurance

The ability of the body to use oxygen efficiently in order to delay the onset of fatigue. When an exercise lasts longer than a minute or two, the muscles get most of their energy from processes that require an increased supply of oxygen delivered to the muscles and tissues. These activities are called aerobic, meaning 'with air'.

Aerobic activities include running, brisk walking, swimming, cycling, rowing, cross-country skiing, rope skipping and aerobic dance.

## Anaerobic Endurance

The ability of the body to delay the onset of fatigue using energy systems that do not require oxygen. During exercise, a muscle requires about fifty times more oxygen per minute than at rest. To reduce the demand for oxygen the muscles are able to convert glucose into energy, without the use of oxygen. For a short period of time, this process, called anaerobic glycolysis, is a highly efficient means of harvesting energy. Unfortunately, an accumulation of lactic acid which results from intense exercise causes the energy processes within a cell to cease, which eventually fatigues the muscles.

## Muscular Endurance

In many ways this is closely related to anaerobic endurance as it involves the ability of local muscle groups to exercise for a long period. This occurs because muscle groups required to perform particular tasks are able to use energy systems efficiently and thus have high levels of endurance.

Resource material: Shot putt

## GENERAL RULES

The competitor must start from a stationary and balanced position inside the circle. The throw is made from a 7ft. (2.135m) circle with a 4ft. (1.22m) wooden stopboard at the front.

The thrower must not leave the circle until the implement has touched the ground, and then his/her first contact with the ground outside the circle must be from the rear half of the circle. The shot must be put from the shoulder with one hand only. In the preliminary stance, it must be held close to the chin, and the hand must never drop below that position throughout the throw.

## HOLDING THE SHOT

The shot is supported and held on the base of the fingers with the thumb and small finger supporting to prevent sideways displacement. The fingers should not be spread out too wide.

Place the shot correctly into throwing hand. Straighten arm upwards directly over the shoulder. Now pull shot down straight and place at the base of the jaw with the elbow held high.

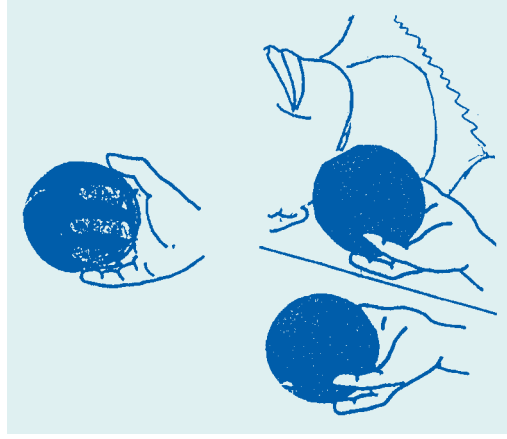

## FACE ON THROW DRILL ONE HAND (1)

Aim: Co-ordination of legs and arms in the throwing movement

Stand with feet in line shoulder width apart, facing the direction of the throw. Using the arm only, the shot is pushed out, ensuring that the elbow is kept high and that the shot is kept close into the chin prior to the movement commencing.

## FACE ON THROW ONE HAND (2)

Stand with both feet in line facing throwing direction. Shot held correctly against neck, rotate backward without shifting feet and drive forward and throw.

## SIDE-ON THROWING

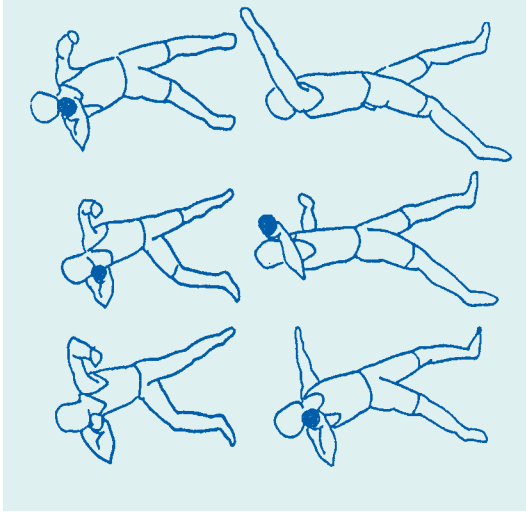

- For the right handed thrower the chin, knee and toes of the right leg should be in vertical alignment.
- The back should be straight and not rounded. Keep weight over the rear foot.
- The feet should be spaced shoulder width apart (depending on the height of the student) with the toes of the left foot in line with the heel of the right foot for right handed throwers.
- The student positions his weight over the right leg and is on the ball of the foot. Top half of body looks to the back. Lower body faces forward.
- Rotating on the ball of the right foot the athlete drives the right hip around - and up to the front. The left side is held firm and either acts as a brace or helps the lift.
- During this action the emphasis should be on a fast right hip, keeping the elbow up behind the shot and following the shot right out with a fast arm action.

Standing frontal putt, not using legs

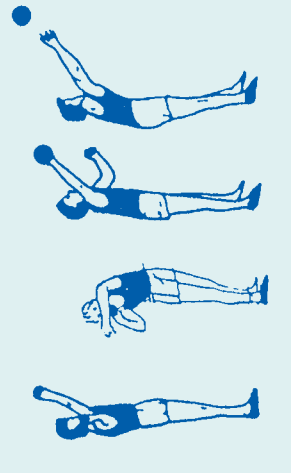

Standing frontal putt, using legs

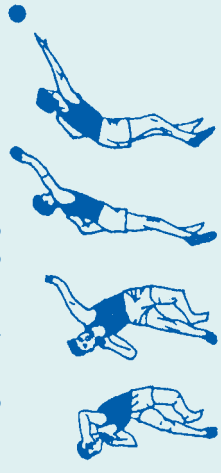

Resource material: Relay activities

**THE PURSUIT**

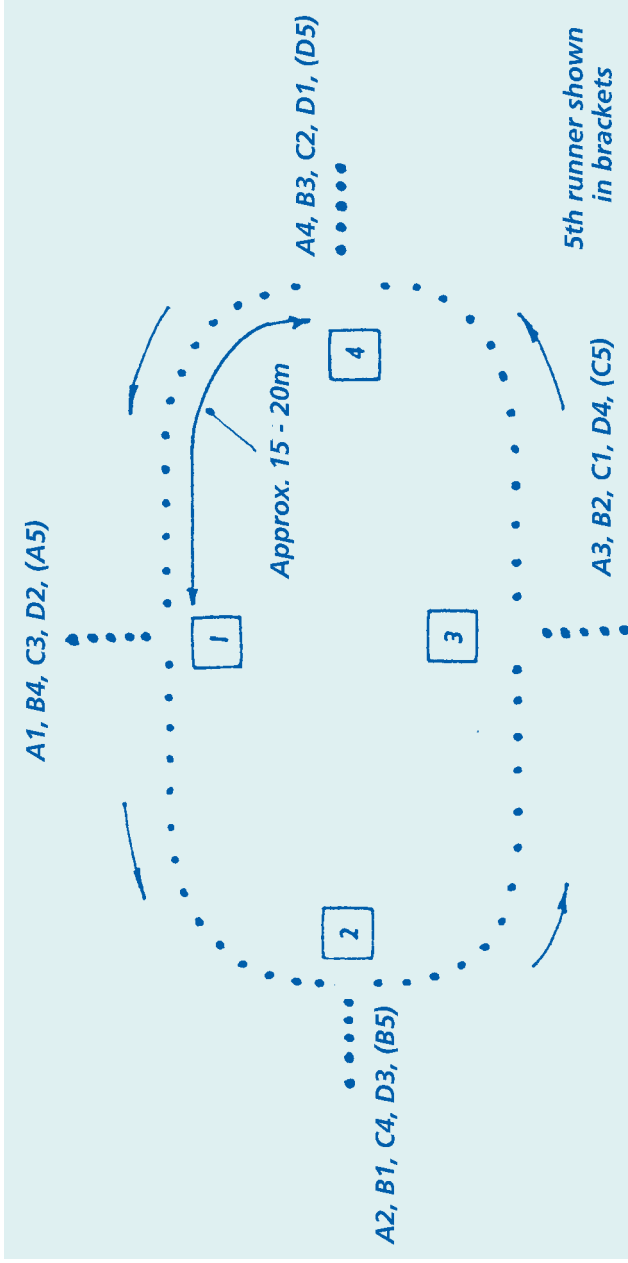

There are 4 teams of 5.

Consider team 'A'. The 1st runner is 'A1'. And the 5th runner is 'A5' shown. The position of the 1st and 5th runners of the other teams is shown in a like manner.

All the 1st runners of each team are given a baton and when the whistle goes they run anti-clockwise, 'A1' giving the baton to 'A2' and so on.

Team 'A' is chasing team 'B' - team 'B' is chasing 'C' - team 'C' chases 'D' and 'D' is chasing 'A'.

When the baton reaches the 5th runner they continue passing it on again to the 1st, 2nd and 3rd and so on, round and round until the 5th runner is back in his / her starting place at which point the baton is held aloft to indicate that the team has finished. All members of all teams should have run 4 times and each team will have covered 5 laps.

It does help if some identification such as a coloured band can be given to the 5th runner of each team.

Resource material: Relay activities

### MEMORY RELAY

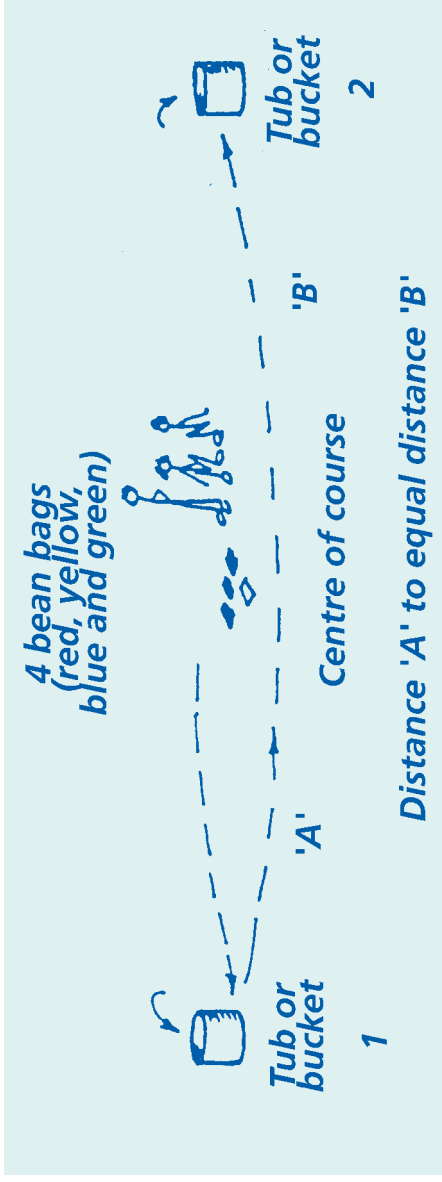

There can be any number of teams depending on equipment available.

Each team is positioned at the centre of the course in a lane or distinct clear running area. At either end of each team's lane a bucket or tub is placed.

The relay is under the control of a caller who calls instructions in a loud, clear voice.

The tubs are designated '1' and '2' and there are 4 coloured bean bags allocated to each team placed at the centre.

#### Starting sequence

The caller shouts instructions such as, '**RED TO 2**', and the team members must take the red bag to tub 2.

This can be followed by '**BLUE TO 1**' and the blue bag must be taken to tub 1.

The caller follows by instructing the teams to place the yellow and green bags in tubs so that all 4 bags are in tubs. There could be 2 in each tub or 3 in 1 and 1 in the other. It does not matter.

Now the memory sequence starts

The caller shouts a colour and the team must remember which tub that it was in and send a member to get it and transfer it to the other tub. The quickest team gets a point.

Teams can get quite confused for they must remember where the colours are and the pace can be quite fast.

Resource material: Class competition

ACTIVITIES FOR UNIT 6. PLAN OF FLOOR

(a) Standing Long Jump

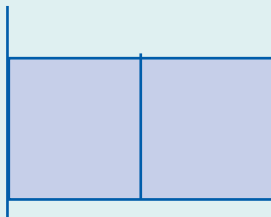

Jump from line  
Mats on floor  
or  
measuring tape

(b) Seated throw from behind head



Floor marked with tape/chalk or cones, prior to competition

(e) Standing Triple Jump

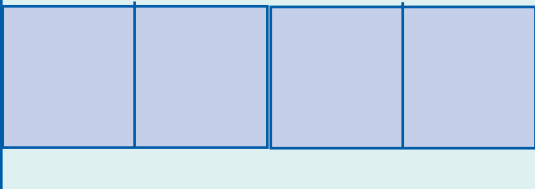

Gymnastics mats on floor  
or  
measuring tape

(d) Shot Putt / Medicine Ball Throw

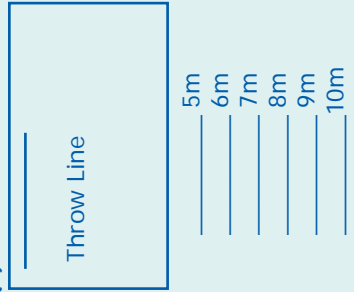

Groups rotate clockwise.

Teacher or students officiate/supervise at station (c).

Each student records best jump/throw (combine best 4 scores for team score).

Scoring : At each station top scoring team receives 40 points, second team receives 30 points, third team receives 20 points and final team receives 10 points.

Combine scores with relay scores.

# Athletics



Level  
Two

# Learning Outcomes

*The student will:*

- *learn how to execute a 'crouch start' correctly and develop an understanding of why it is used and the rules governing it*
- *enhance his/her ability to jump for distance and/or height through an understanding of jumping*
- *improve his/her ability to throw for distance using a variety of implements*
- *develop his/her ability to run over obstacles*
- *develop an understanding of the principles in relation to:*
  - *running for speed*
  - *jumping for distance and height*
  - *throwing implements for distance*
- *apply the safety procedures associated with:*
  - *participation*
  - *handling and using equipment*
  - *fitness requirements for athletics events, including warm up and cool down*
- *display knowledge of:*
  - *the rules of individual athletic events*
  - *the rules in relation to measurement of particular events*
- *set personal challenges.*





# CONTENT FRAMEWORK

## **CONTENT SELECTION**

Warm up activities should be related to the specific content of the lesson and should follow the principle of general to specific.

### **UNIT 1: RUNNING AND JUMPING**

Running drills  
Crouch start  
Jumping drills

### **UNIT 2: THROWING AND JUMPING**

Aerobic warm up  
High jump – scissors jump  
Throwing drills  
Beach ball team competition

### **UNIT 3: THROWING**

Development of overarm throwing technique

### **UNIT 4: RUNNING OVER LOW OBSTACLES**

Use of hurdles grid  
Crouch start  
Linear relay

### **UNIT 5: RUNNING AND JUMPING**

Development of one of the jumping events

### **UNIT 6: COMPETITION**

Assessment of running, jumping and throwing in group challenge

### **INTEGRATION**

Possible opportunities within each lesson for integration with health related activities, e.g.

- pulse rate and recovery
- endurance
- elastic strength
- flexibility.



LEARNING  
OUTCOMES

- The student will:
- develop his / her understanding of the principles of starting
  - demonstrate the correct technique of a crouch start
  - demonstrate his / her ability to jump for height.

## EQUIPMENT

Whistle, bollards, suspended balls

## CLASS ORGANISATION

Large indoor/outdoor area, students run in one direction.

## STAGE

## Warm up

- Revision of running drills from level 1 – heel flicks, striding, knee raising. Include “cross-over stepping”.
- Stretching routine

## Development

- Revise standing start from level 1
- Practice ‘one hand down’ start
  - Repeat x 6 / 8
- Student on all fours to help develop:
  - Crouch Start**
    - Student/teacher demonstration first
    - Students practice in pairs
    - 20m sprints using crouch start

**Jumping**

- Revise verticle jump and one step verticle jump from level 1 (lead up to high jump).
- Heading ball game!

## Cool down

Gentle stretching routine

## CONTENT / ACTIVITY

## TEACHING POINTS

- Jog between drills, look for good technique at all times.

- Place weight on front foot, lean forwards, be on toes of back foot, opposite arm to leading foot in front, other arm back, push off fast on ‘Go’!

- Place one foot to the line, but behind it. Weight is balanced forward onto this foot. Support body with one hand on the ground (see resource material):

- On ‘Go’, push off the front foot, drive forcefully with both arms.

- See resource material

- Ensure the drive is low at ‘Go’.
- Look for good technique at all times (position & drive)
- Stand behind / to the side when starting students— vary stimuli (clap, whistle)

- <sup>a</sup> Drive with legs, swing arms, keep head and trunk upright.

- See resource materials, you may play using 1 Step, 3 Step or 5 Step approach.

Unit 2

**LEARNING OUTCOMES**

- The student will:**
- develop his / her understanding of the principles in relation to jumping for height
  - develop his / her throwing skills.

**EQUIPMENT**

Cones, canes/high jump standards, basketballs, tennis balls, beach ball.

**CLASS ORGANISATION**

**STAGE**

Warm up

**Aerobic activity**

Include running / jumping drills, “cross over stepping” and stretching.

**CONTENT / ACTIVITY**

**TEACHING POINTS**

- Have students jog/walk between drills.
- Look for good technique and ensure all stretches are done correctly.

Development

**Vertical Jump High Jump**

- Begin with scissors jump
  - Use 1 stride run up
  - Use 3 stride run up
  - Use 5 stride run up off curve

- Use suitable high jump landing area.
- Use cones and canes or high jump stands with foam / rope/ elastic bar.

- Take off on foot away from bar
- Swing upwards arm and free leg
- Cross bar in sitting position
- Keep trunk upright, head high (see resource materials for development of high jump).

**Throwing**

- Two throwing drills e.g. 2 handed chest throw, 2 handed overhead throw, etc.
- Team competition with beach ball or basketball (see resource materials).

- There are throwing drills in the resource material

Cool down

Gentle jog and stretching routine.

Unit 3

**LEARNING OUTCOMES**

- The student will:**
- apply safety measures associated with throwing
  - improve his/her ability to throw using one handed, overarm throw.

**EQUIPMENT**  
Soccer balls, basketballs, bean bags, tennis balls, hoops, indoor javelin.

**CLASS ORGANISATION**

Safety is paramount!  
Ensure all throwing is in one direction only.

STAGE	CONTENT / ACTIVITY	TEACHING POINTS
Warm up	<ul style="list-style-type: none"> <li>• Gentle aerobic activity, followed by stretching routine and basic throwing drills.</li> </ul>	<ul style="list-style-type: none"> <li>• Ensure main muscle groups for throwing are stretched.</li> <li>• Use chest pass / overhead pass drills.</li> </ul>
Development	<ul style="list-style-type: none"> <li>• Begin with 2 handed soccer throw                             <ul style="list-style-type: none"> <li>– Move from 2 feet to 1 foot</li> <li>– Move from 1 foot to 2 feet to 1 foot (in pairs).</li> </ul> </li> <li>• Do standing frontal throw, one handed, feet square.</li> <li>• Do standing throw, feet square, turning shoulders to side.</li> <li>• Turn shoulder to right (throwing arm), reach back and step.</li> </ul> <p><b>Option</b></p> <ul style="list-style-type: none"> <li>• Practice with foam javelin (see resource material).</li> <li>• Target throwing competition (see resource material).</li> </ul>	<ul style="list-style-type: none"> <li>• Ensure students keep elbows in and above eye level.</li> <li>• Get ball back as far as possible but keep above head level.</li> <li>• Bring arm straight back with elbow high (at eye level).</li> <li>• Step onto opposite foot from throwing arm, bring elbow through high and close to head.</li> <li>• Follow through and release.</li> <li>• If you have foam/indoor javelin, allow students opportunity to throw</li> <li>• The target throwing competitions are good fun, but also help develop technique used in javelin throwing -</li> </ul>
Cool down	Gentle jog and stretch.	<ul style="list-style-type: none"> <li>• Revise throwing technique points by questioning while students are stretching.</li> </ul>

Unit 4

**LEARNING OUTCOMES**

- The student will:**
- develop his/her ability to run over low obstacles
  - develop an understanding of how to “hurdle” correctly.

**EQUIPMENT**

Ropes, cones, canes, whistle, foam wedges, low indoor hurdles.

**CLASS ORGANISATION**

Have students grouped according to ability to pace 3 strides.

STAGE	CONTENT / ACTIVITY	TEACHING POINTS
Warm up	<ul style="list-style-type: none"> <li>• Aerobic warm up, followed by stretching – include running drills and running over low obstacles.</li> </ul>	<ul style="list-style-type: none"> <li>• The obstacles used should be at even intervals apart.</li> <li>• Even ropes will do for obstacles, but whatever you use ensure they are low and safe.</li> </ul>
Development	<ul style="list-style-type: none"> <li>• <b>Hurdles grid</b> – see resource material. Have students <b>run</b> over low obstacles, increasing distance between obstacles as students improve.</li> <li>• <b>Revise crouch start</b> <ul style="list-style-type: none"> <li>– 1 hand down</li> <li>– Full crouch position</li> </ul> </li> <li>• <b>Combine crouch start and run</b> over 2/3 obstacles, still working on hurdles grid.</li> <li>• <b>Hurdle out, run back relay</b> (see resource material).</li> </ul>	<ul style="list-style-type: none"> <li>• Encourage running over obstacles and <b>not</b> jumping (keep centre of gravity low).</li> <li>• Look for students to develop “1 – 2 – 3” rhythm between obstacles. If they are too close move up the grid, too far apart move down the grid.</li> <li>• Increasing speed helps to reach hurdles further apart.</li> <li>• Look at position of feet, hands, body in “Marks, Set, Go” positions.</li> <li>• Encourage low drive coming out of set position.</li> <li>• Ensure obstacles are no higher than 30cm and let students go to course to which they are best suited – “Run over obstacles”, “1 – 2 – 3”.</li> <li>• Run in groups of 4 / 5.</li> <li>• 3 obstacles is adequate, depending on space available if indoors.</li> </ul>
Cool down	<ul style="list-style-type: none"> <li>• Gentle jog and stretching.</li> </ul>	<ul style="list-style-type: none"> <li>• Remind students of the need to run, <b>not</b> jump over the obstacles.</li> </ul>

## Unit 5 Foreword to Unit 5

Having worked on the fundamentals of running, jumping and throwing, you may wish to expose students to a ‘real event’. The facilities available to you may dictate what event you can teach. The following unit is for the long jump, but you may change this for some other event if you wish.

The student will:

- develop an understanding of the components of the long jump – run up, take off, flight, landing
- perform long jump into a sand pit.

### LEARNING OUTCOMES

### EQUIPMENT

Sand pit, non-slip runway, cones, measuring tape.

### CLASS ORGANISATION

An outdoor area is required with sand pit. Try to avoid having students standing for long periods.

## STAGE

## CONTENT / ACTIVITY

## TEACHING POINTS

### Warm up

- Aerobic activity followed by good stretching routine.
- Revise some running drills and jumping drills.

- Never allow students do any jumping until they are well warmed up.
- Outline safety concerns while they are stretching (see teacher guidelines).

### Development

- Instruct students on correct landing technique.
    - 1 step and jump into pit
    - 3 steps and jump into pit.
  - Explain why a run-up is measured (taking a mark) before jumping.
    - Set out cones and have students practice in pairs taking 9 or 11 stride run-up.
  - Run, take off, in flight position, landing (see resource material).
    - Divide class into 3 groups:
      - Group A: 3 jumps each
      - Group B: Practice and measure standing long jump
      - Group C: Practice and measure one step long jump.
- Rotate 3 groups
- Measure individual jumps
  - 9 or 11 stride run-up.
  - Don't look at board, jump high.

- Extend both legs in preparation for landing.
- Flex the legs as soon as contact is made with the sand.
- Ensure upper body moves forward and over the feet – don't sit back.
- Explain how conditions can alter your run-up. Insist on same speed out/back!
- This may be done on running track or in field, just so students experience trying to take a mark.

- Do not measure jumps initially, just let students run, jump into air, extend legs, land, flexing knees as soon as contact is made with sand.
- Ensure pit is dug and raked regularly.

- Students measure each others jumps.

### Cool down

Gentle jog and stretch.

- Go through basic rules of long jump (see resource material) while students are stretching, but you may wish to do this during the unit.

Unit 6

**LEARNING OUTCOMES**

- The student will:**
- perform a throw from behind head and chin
  - perform two jumping tests
  - perform a speed bounce test
  - score a simple sportshall competition.

**EQUIPMENT**

Scorecards/blackboards, bench, basketball, indoor shot, cones, low obstacles, tapes, speed bounce mats.

**CLASS ORGANISATION**

Similar to unit 6, level 1.

**STAGE**

**CONTENT / ACTIVITY**

**TEACHING POINTS**

**Warm up**

- Aerobic activity around hall, include skipping and hopping drills – do good stretching routine.

- Link warm up to tests you will be using later in class. Anything in this unit can be swapped for something else.

**Development**

- Students to be organised into groups. Each requires score card and pen (sample in resource materials).
- Each team begins at one of the 4 stations (or 5 if time allows).
  - Standing long jump
  - Seated throw, behind head (basketball)
  - 3 hops, 1 step and jump.
  - 1 step shot putt
  - Speed bounce
- All teams compete in linear relay over low obstacles.

- Have floor pre-marked.

- Explain/demonstrate each test.
- Allow best score of 2 attempts at each, except speed bounce.
- Rotate groups every 5/8 minutes.

- Teacher may record group scores onto master sheet during class.

**Conclusion**

- Tabulate scores to find winning group.

- You may use all students scores from group to get group total, or perhaps best 4 from 5.

**ONE-HANDED STANDING START****INITIAL POSITION**

**Command:** On your marks

The students are asked to stand upright.

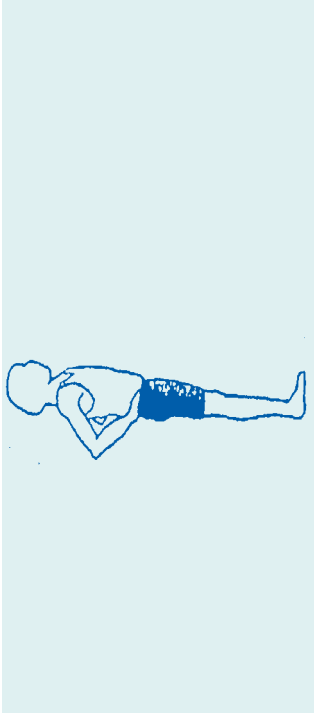
**NEXT STEP**

**Command:** Set

The student places one foot to the line but behind it. Weight is balanced forward onto this foot. One hand is placed on the ground to support the body.

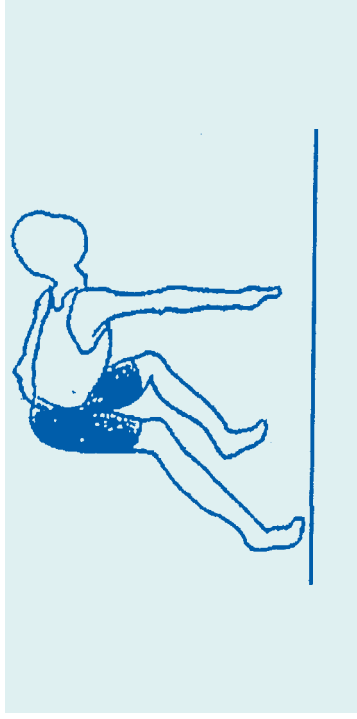
**FINAL STEP - THE RUN STARTS**

**Command:** Go

The student pushes off the front foot. Both arms are used – driving them with great force.

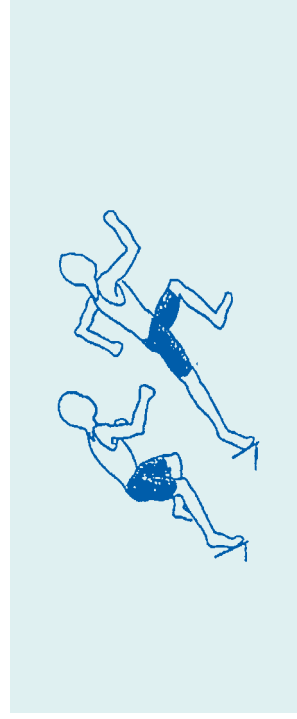



Resource materials: The crouch start

**CROUCH START**

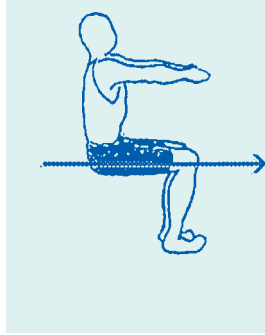

**STEP ONE**

The student is asked to kneel down on all fours with the hands placed immediately behind the starting line.

The desired position is one where the upper leg (thigh) and arms are perpendicular to the ground.

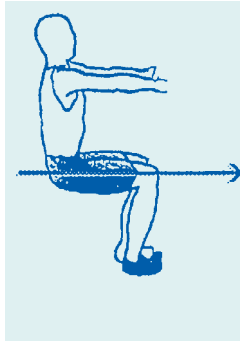

**STEP TWO**

The student turns in toes of the rear foot.

Hint: The student is told to dig in the toes just as if she / he was looking to get a grip. This will be the actual position of the rear / back foot.

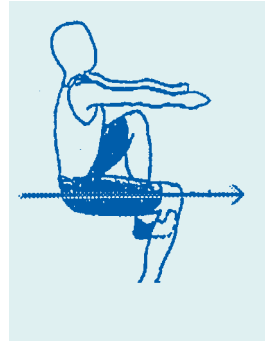

**STEP THREE**

The front leg (strong leg) is brought forward until the toes are 2" to 4" behind the knee of the rear leg. This is a choice for the student.

The student is now in a position to make personal adjustment to suit age, strength and comfort levels.



**YOUNGER STUDENTS**

Younger students' arms may not be strong enough to support their bodies in the "set" position. Thus the lead knee and trail foot may be moved nearer to the start line to lighten the load on the arms.

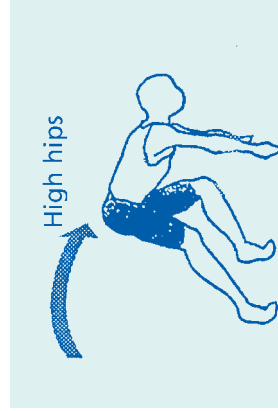

**STEP FOUR**

The set position: The student raises his / her hips high. The knees leave the ground.

How high should one raise the hips? An angle of about 90° is made at the front knee and an angle of about 130° at the back or rear knee.

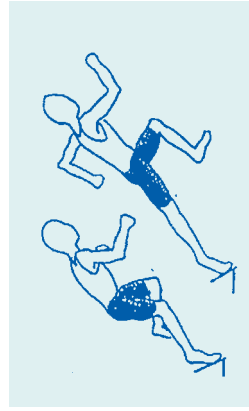

**STEP FIVE**

The student should remain motionless and to wait for the signal. Anticipation will only bring rewards once in a while.

The reaction and drive.

Resource material: Heading the ball

**Numbers**

Open

**No. of Teams**

Individuals or teams

**Light balls**

Enough to ensure maximum participation.

The balls are suspended from the ceiling or some fixed high objects.

**The Set-up**

The balls are suspended at different heights. The lowest one has a value of 1 point, the next lowest 2 points and so on. The highest ball has the highest value.

**Rules**

Each time an student runs, jumps and makes contact with a ball, she/he scores the value of that ball for their team.

**How to Play**

There are two options.

Option one:

Each student attempts to touch or head the one point ball. Then each one attempts to head the two point ball, and so on.

Option two:

Each student has a given number of attempts at scoring the highest possible score. For example, each student is allowed four jumps. She/he may select to jump at whatever ball she/he wishes. They may even try the same ball each of the four times. In this way some students can score high points, but also run the risk of missing out.

Ensure that most students will score quite a number of points by placing most balls at a height accessible all.

**Winner**

The individual winner is the player who scores the greatest number of individual points.

The winning team is the team whose total score is the highest.

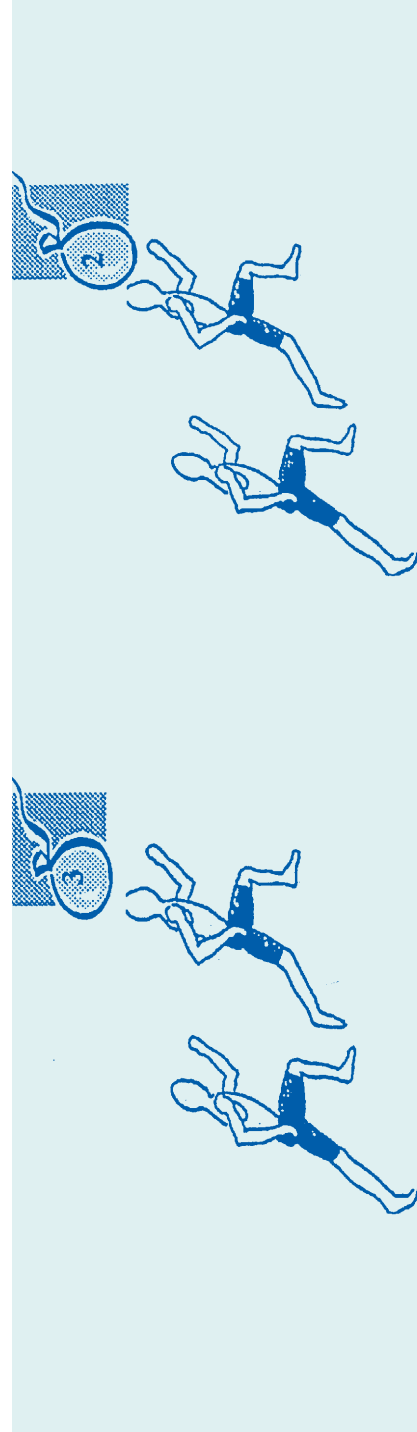

## The Throwing Events

### Common movements

Legs first, arms last

Weight transfer  
Extension

Non-throwing side brace

At their most fundamental level the shot, discus and javelin involve the following action sequences. If these elements are practised and mastered, the students will be well equipped to develop the skills of throwing further. Descriptions relate to right-handed thrower.

#### **Weight Transfer from Right to Left**

The final throw is initiated by the right foot/leg rotating the hips forward, transferring the weight over the left (front) leg.

#### **Legs first, arms last**

It is important that the very strong, but slower moving muscles of the lower limbs accelerate the implement initially. The weaker, but fast moving, muscles of the arms can only be effective when the implement is moving quickly and therefore the arms are used as late as possible.

**FAST AND LAST.**

#### **Extension**

The implement is always released from a stretched, high position – the thrower starts low and finishes high.

#### **Left side brace**

It is quite common to find students collapsing the left side of the body just before release. The left side should be braced to allow the right side to accelerate round or over it. A strong, powerful release position should be taught.

Resource material: Throwing activities

**TWO-HANDED THROW WITH A BASKETBALL**

While sitting, the athlete uses both hands to throw a basketball from behind the head. This activity forces the thrower to lean back and pull the basketball vigorously over the head and helps the thrower to experience the stretch-pull action of the muscles of the chest and shoulders.

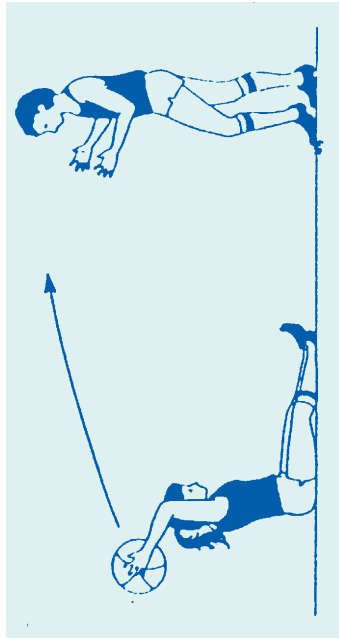

- Reach back as far as possible behind your head with the basketball.
- Without overbalancing backward, let your elbows drop back as far as possible.
- Pull the ball forward and throw it as far as possible.
- Flex your arms at the elbows and lead the pulling action with your elbows.
- Extend the throwing action as far in front of your head as possible.

**TWO-HANDED BASKETBALL THROW FROM A KNEELING POSITION**

This activity is similar to the previous drill except that the thrower is in a kneeling position. This drill simulates the pull of the javelin over the thrower's head.

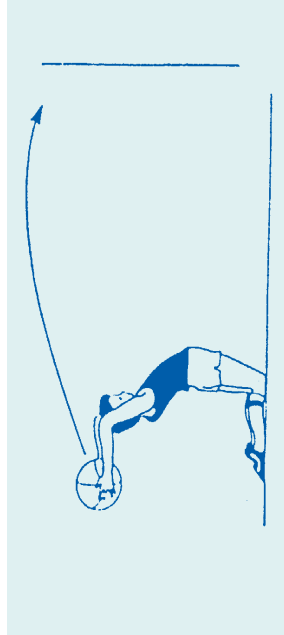

- Tilt back to a position that you can comfortably control.
- Pull the ball forward as vigorously as possible.
- Contract your stomach muscles to help pull your chest forward.

**TWO-LEGGED JUMP AND THROW**

This practice is quite difficult and demands good co-ordination and quick explosive muscle actions. It simulates the pull on the javelin and in doing so strengthens the abdominal muscles. Novices should begin with a small jump and a push-throw from above the head. The action then progressively builds so that each performer jumps higher and throws the ball from behind the head rather than pushing it from in front.

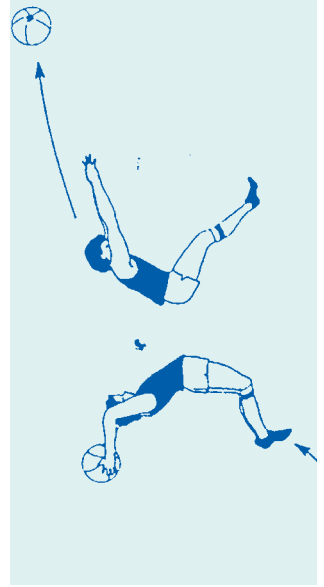

**LIFT, TURN, AND THROW**

A lift, turn, and throw simulates the hip rotation that in the javelin throw. This drill should be performed slowly until the required actions are well learned. Thereafter, it can be made more vigorous and explosive.

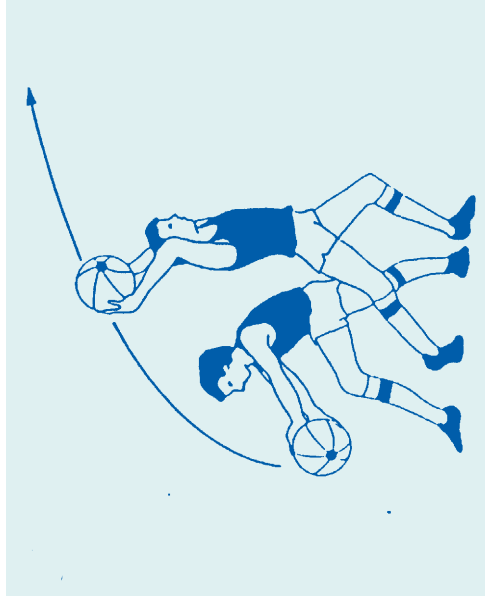

- A right-handed thrower will turn the hips to the front by rotating the knees first in the same direction.
- Imagine a corkscrew action, with your knees turning to the front followed by your hips, chest, and arms.
- Practice the action slowly to begin with, and don't concern yourself with distance.
- As the action becomes more fluid, increase the distances.

Resource material: Throwing activities

**TEAM COMPETITION**

Two teams stand on lines 20 meters apart, with a basketball placed on the ground equi-distant from both teams. Each team throws volleyballs at the basketball, attempting to drive it over their opponents line. Allow one-handed and two-handed throws from above the head only.

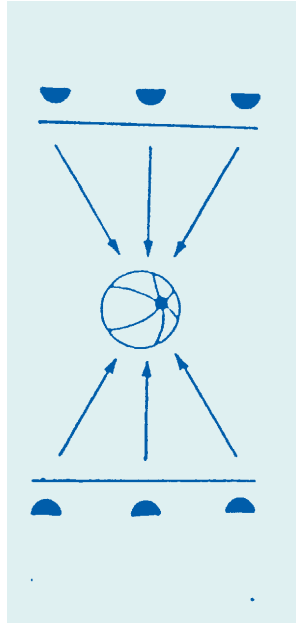

**REACHING BACK TO THROW**

Place several tennis balls (4 to 5) on a box top to the rear of the thrower. The thrower stands in a wide stance (slightly wider than shoulder width). The thrower reaches back, grasps a ball, turns to the front, and completes a standing throw. The balls must be placed far enough back to ensure that the thrower reaches well back with a straight arm, shifting the body weight well over the right foot and partially flexing the right leg. As a variation, a partner offers balls individually on an open palm to the thrower. The thrower must be forced to reach well back to get each ball.



**THROWING AT TARGETS**

Suspend hoops from soccer goalposts or draw circular targets on a wall. Students throw tennis balls at the target from various distances. All throwers throw the same direction, and each begins the throw with the body weight well to the rear and with the throwing arm extended. The targets force throwers to throw both forward and upward. You can award scores for accuracy.

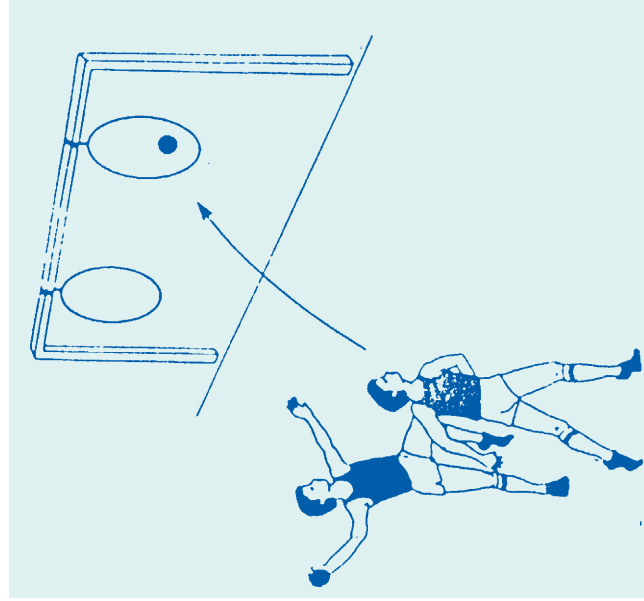

**PRACTICE USING THE SOFT JAVELIN**

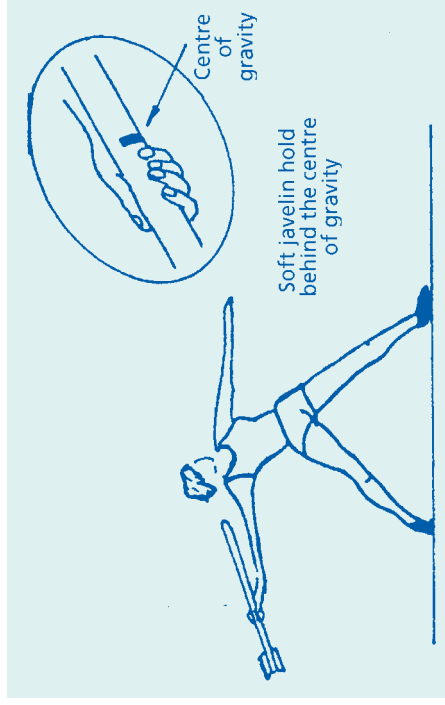

Place one foot behind the other which helps you to make use of the powerful muscles in your legs and practice throwing - not too high and not too low.

Ask the students to observe each others throws and to notice the angle at which the object goes furthest.

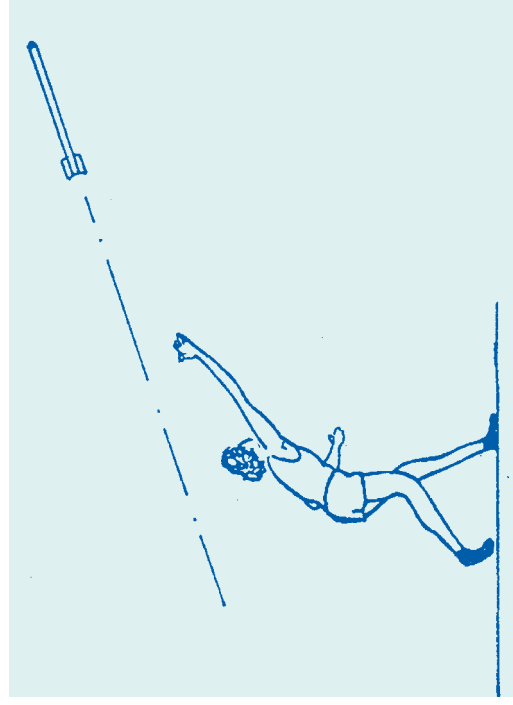

The longer the travel of the arm before releasing, the more the path of acceleration is increased and the faster the javelin or ball will leave your hand.

Appendix 5 (i)

**HURDLES GRID FOR UNIT 4**

This is just a guide; for older or taller students you may need to start grid at 6m and work up from there.

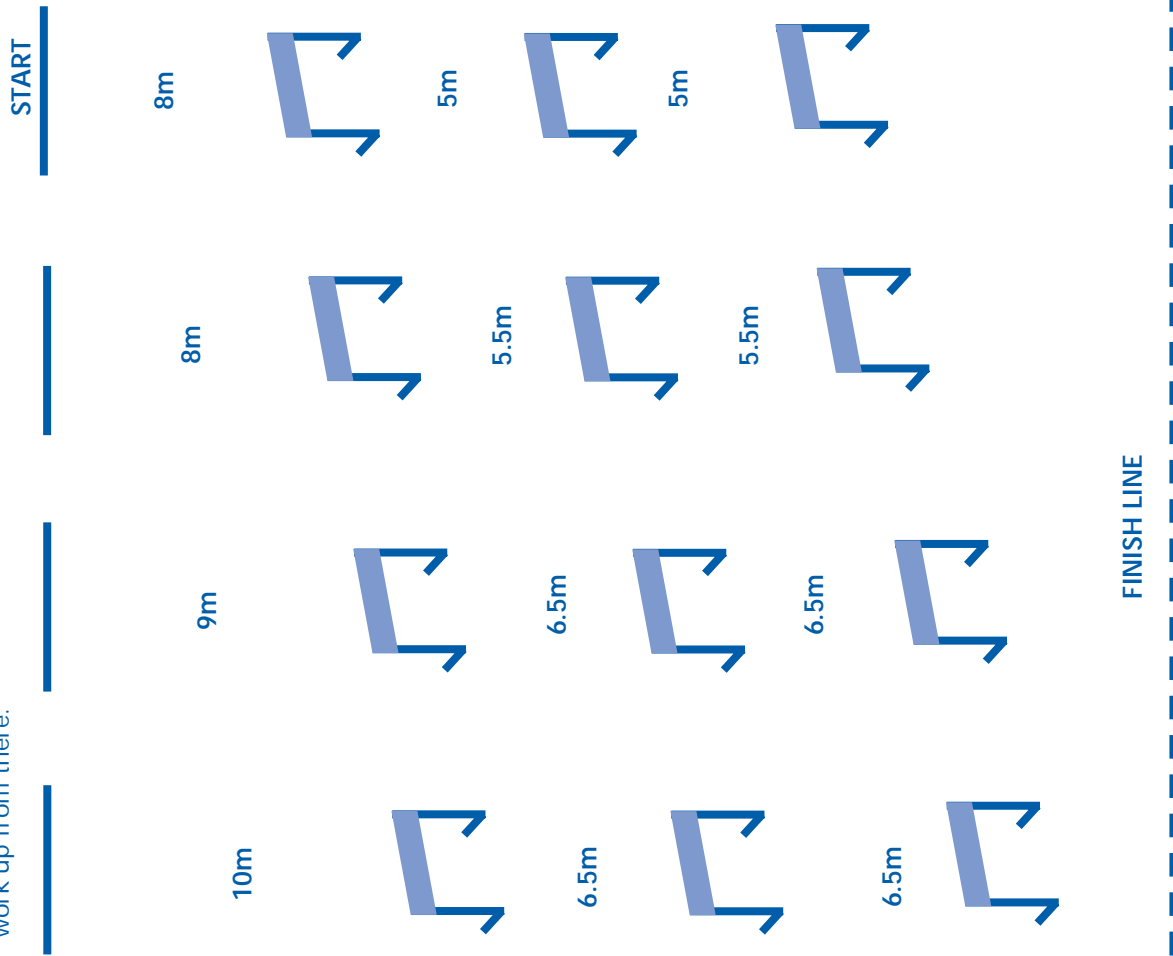

**RHYTHM**

1. Place a number of cane sticks on the track across the lane as shown. Place  $6\frac{1}{2}$  to  $7\frac{1}{2}$  m apart according to age and height.
2. Run over the sticks freely several times developing a four stride pattern. Count the rhythm, i.e., 1, 2, 3, over until it is 'grooved in'.
3. Notice that, with the rhythm, the same leg crosses the stick each time. The student has now quite voluntarily chosen his/her lead leg.
4. Now using cones or blocks gradually raise the height of the sticks to 10 cm, 20 cm, 30 cm, 40 cm, 50 cm. Sticks on cones, foam hurdles or 2-way P.V.C. hurdles should be used.

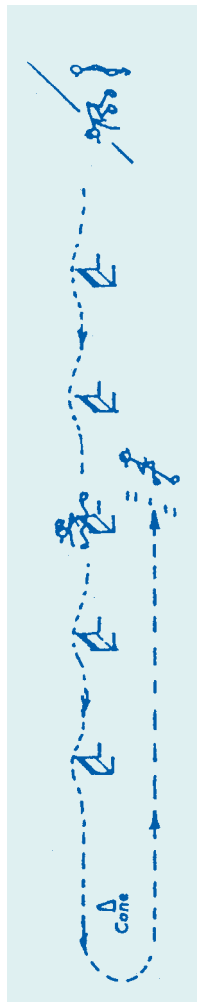
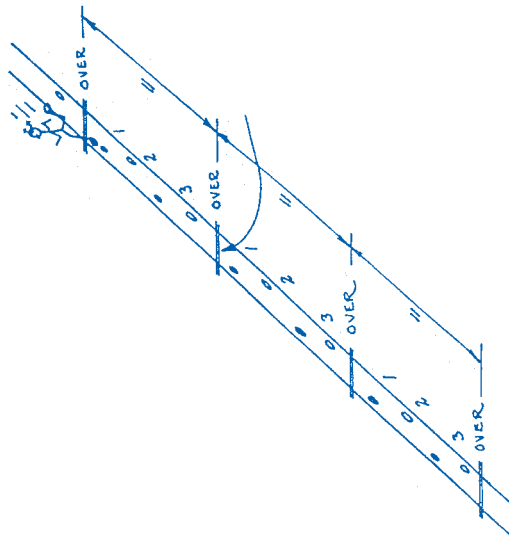

Take-over by touching shoulder of the next student.

**HURDLE OUT RUN BACK RELAY**

Using conventional hurdles. Take-over by touch of shoulder.

- Ensure obstacles are low.
- Increase distance of cone from last hurdle if one team is too good for others.
- Try relay initially in non-competitive situation and encourage students to get "1 - 2 - 3 rhythm" — bring this then into competitive situation.

Resource material: Long Jump

In teaching the long jump to students you must be conscious of several safety factors. The actual teaching of the jump can be broken into 4 sections, but initially allow the students to experience the full movement, before breaking it into its components, namely

- the run
- take off
- technique in flight
- landing

Many students will not jump to any great length because they do not have sufficient speed or spring, but they can still perform a good run-up, take-off, basic 'hang' in flight and good landing, if each component is taught well.

**FACILITIES / EQUIPMENT NEEDED TO TEACH LONG JUMP**

You will need a sand-pit, runway with a board 1/2m from edge of sand, a measuring tape, a rake and shovel. If your sand-pit is particularly large, you may be able to jump students into pit from side.

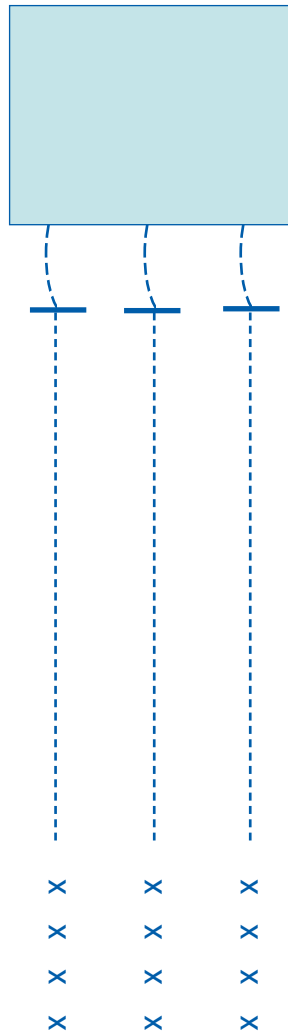

Resource material: Long Jump

## A. The Run-Up

It is important to explain to students the necessity of measuring your run-up ('taking your mark') to get optimum distance in jumping.

A 9/11 stride run-up is sufficient for young students, older students will need to use a longer approach run in order to be at maximum speed on take-off.

Get students to perform the following steps to measure their mark.

1. Each jumper stands in stride position, facing back down the run-way, with the toes of the non-jumping foot placed against the front edge of the take-off board.

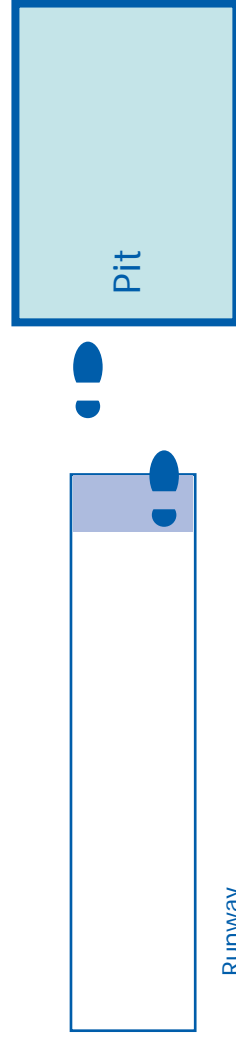

Runway

2. The jumper sprints 9 strides down the runway, with the first stride taken by the jumping foot.
3. The teacher or a student counts each footfall of the jumping leg - 1, 3, 5, 7, 9 (this is much easier than counting every fall).
4. Mark on the runway where the 9th stride landed and this will give an approximate starting point for the run-up.
5. The jumper now puts non-jumping foot on the start/mark and sprints back towards the pit, the jumping foot taking the first stride. The uneven number of strides in the run-up should put the jumping foot on the board for the take-off.

Note - Encourage students to sprint at top speed, both when taking their mark and when jumping. Students often slow-down when approaching their final stride of measuring their run-up.

## B. The Take-Off

Initially, it is much better to allow students take off from a 'take-off area' rather than a board, as this helps students relax a little more during run-up and less concerned about hitting an exact spot for takeoff.

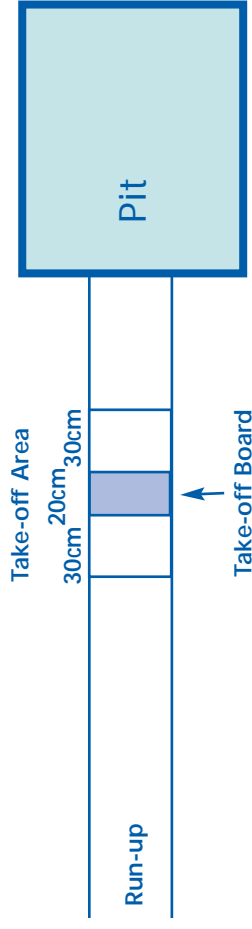

A take-off board is 20cm in width, the extra take-off area can be marked 30cm either side of the board with chalk or tape.

Stand by the take-off area and note the position of the take-off foot and the take-off board. Help the student adjust the start of the run up to bring the take-off as close to the board as possible.

On take-off, you want the student to lift the thigh of the leading leg up and forward and then drive powerfully with the jumping leg. The upper body is perpendicular, head is up with eyes looking forward.



Resource material: Long Jump

## C. Technique In Flight

There are two main techniques used in long jumping: **The Hang Technique** and **The Hitch-Kick Technique**. Both are patterns of movement in flight, designed to keep the jumper in the air for longer and to help get maximum distance.

An **elementary technique** for beginners would be as follows:

- Fully extend the jumping leg at take-off, flex the leading leg with the thigh raised to horizontal
- Keep upper body perpendicular, vision ahead and upward
- Have arms compliment the action of the legs
- In flight, the leading leg extends and the jumping leg trails so that the jumper is momentarily in a stride position
- For landing, the jumping leg is brought forward, and both legs extend, landing together
- The legs flex at the knees on contact with the sand.

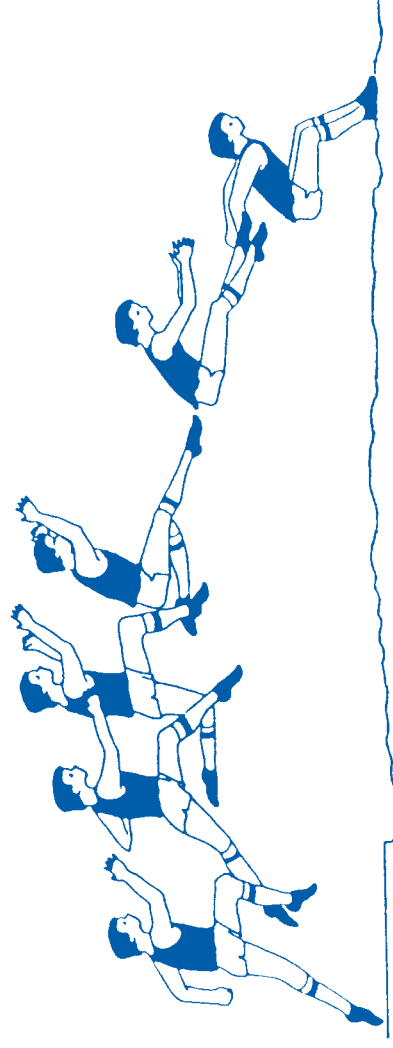

Elementary long jump technique

## D. Landing

Whatever technique the students use in jumping, always insist on the following for landing:

- Extend both legs in preparation for landing
- Flex the legs at the knees as soon as contact is made with the sand
- Ensure upper body moves forward and over the feet.

Various practices may be used to improve technique, some of the following may be of benefit.

Resource material: Long Jump

### STANDING LONG JUMP USING A TWO-LEGGED TAKEOFF

The student uses a strong swing of the arms coupled with a double-legged drive to cover as much distance as possible.

#### TEACHING POINTS

- Extend your legs as powerfully as possible and combine that action with a strong swing of the arms.
- Pull the legs forward underneath your body to cover as much distance as possible.

### STANDING LONG JUMP USING A SINGLE-LEGGED TAKEOFF

This is similar to a bounding stride except that both legs are brought together for the landing. Participants jump using their favoured and non favoured legs for the takeoff and then compare distances.

#### TEACHING POINTS

- Extend the jumping leg as powerfully as possible.
- Swing the leading leg up to horizontal.
- Use your arms in the same fashion as with the two-leg jump. Swing both of them up and forward in unison with the leading leg.
- Jump for distance with each hop, not height.

### HOPPING FOR DISTANCE AND FINDING THE FAVOURED JUMPING LEG

Measure the distance each participant can achieve in 3 successive hops from a standing start with the right leg only. Measure the distance gained from the same action performed with the left leg only. The leg which produced the greater distance is the preferred jumping leg.

### BOUNDING FOR DISTANCE

In this lead-up activity, the thigh of the leading leg is lifted to horizontal with each bounding stride. The performer should strive for long strides, reaching for distance.

#### TEACHING POINTS

- Swing your arms up and forward with each bounding stride.
- Try to achieve a wide stride position at the midpoint of each bounding stride.
- Try to get a feeling of 'floating' at the midpoint of the stride.

### DISTANCE JUMPING COMPETITION

From a line, participants see how far they can jump in total with 3 successive two-footed jumps (rabbit hops). Who can go the farthest?

#### TEACHING POINTS

- Don't put everything into the first of the 3 jumps.
- For optimal distance, all 3 jumps must be fairly equal in length.
- Avoid jumping upward. Jump low and forward.

#### VARIATION

The first member of a team completes 3 two-footed jumps (or 3 bounding strides). The next member of the team adds 3 more jumps to increase the distance achieved. Which team can accumulate the greatest distance?

Resource material: Overall Score Sheet (sample)

OVERALL SCORE SHEET					
	A	B	C	D	E
	TOTAL SCORE POINTS	TOTAL SCORE POINTS	TOTAL SCORE POINTS	TOTAL SCORE POINTS	TOTAL SCORE POINTS
1. STANDING LONG JUMP					
2. SEATED THROW					
3. SHOT PUTT					
4. SPEED BOUNCE / SKIPPING					
5. 3 HOPS, 1 STEP & A JUMP					
6. RELAY EVENT					
TOTAL POINTS					
POSITION					

1st in each test may get 30 points, 2nd 25 points, 3rd 20 points, etc. You decide points!

GROUP SCORE SHEET					
NAMES	ST. LONG JUMP	SEATED THROW	SHOT PUTT	SPEED BOUNCE	3 HOPS, 1 STEP, JUMP
Total (Best Four)					

Resource material: Event rules

### LONG JUMP

- Athletes may only take permitted number of jumps.
- Touching the take-off board is permitted, touching any part of the ground beyond it however is classified as a break.
- The measurement is taken from the mark in the sand, closest to the board.
- The measurement is taken in a straight line back to the board and is read from the edge of the board, closest to the sand.
- The athlete with the longest jump is declared the winner. In the event that two athletes jump the same distance, their next best jump decides who gets the higher placing.

### TRIPLE JUMP

- Most rules as for the long jump, with a few extra.
- The athlete must do the event in order — hop, step, jump.
- The trail leg may not touch the ground between stages of the jump.
- Two hops or two steps is a foul jump.

### SPRINT STARTS

- Athletes must go into a crouch start for all competitive sprint events.
- Starting blocks may be used, but they must be totally inside the athletes lane.
- If an athlete false starts twice, he/she is disqualified.
- If an athlete crosses lanes and interferes with another runner, he/she will be disqualified.
- The first athlete to reach the line is declared the winner.

### 4 X 100 METRE RELAY

- Runners 2, 3 and 4 have a 20 metre zone in which they must receive the baton.
- The zone is marked 10 metres either side of the 100m, 200m and 300m marks.
- The receiving athlete may begin their ~ outside the zone but can only take the baton inside the zone.
- Changeovers outside the zones will lead to disqualification.
- If an athlete interferes with another team, that persons team will be disqualified.
- If a baton is dropped, the runner that drops it must pick it up, the next runner may not do so.
- If a baton is dropped into another lane causing interference with another team, the team will be disqualified.
- The rules governing sprint starts also apply to the 4 x 100m relay.

### HIGH JUMP

- Competitors may start jumping when they wish.
- They may skip a height if they so wish, but three consecutive failures results in elimination.
- A jump is counted as a failure if the bar is knocked:
  - if he/she takes off from two feet
  - if the jumper touches the landing area or the ground beyond the plane of the uprights without first clearing the bar ( whether or not a jump is made).

### JAVELIN

- Generally, a competitor will have between three and six throws, depending on the competition.
- The thrower must hold the javelin at the grip and throw with one hand only.
- The javelin must land within the permitted area to be valid.
- A throw is a foul if a competitor touches with any part of his/her body the arc or scratch lines or the ground beyond them.
- The competitor must not leave the delivery area until the javelin has landed and must then leave from behind the arc and scratch lines.
- A throw is measured from the nearest mark made by the head of the javelin to the inner edge of the circumference of the arc.
- The weight of the javelin varies depending on the age involved.



- Creative Dance

- Folk Dance

# Dance



*the skeleton the blood  
volcano the  
environment  
hieroglyphics*



# CONTENTS



	<i>Page</i>
<i>Introduction</i> .....	<b>182</b>
<i>Overall Aim &amp; Objectives</i> .....	<b>182</b>
<i>Teacher Guidelines</i> .....	<b>183</b>
<b>Level One</b>	
<i>Creative Dance</i> .....	<b>187</b>
<i>Learning Outcomes</i> .....	<b>188</b>
<i>Content Framework</i> .....	<b>188</b>
<i>Units</i> .....	<b>189</b>
<i>Resource Material</i> .....	<b>196</b>
<i>Folk Dance</i> .....	<b>197</b>
<i>Learning Outcomes</i> .....	<b>198</b>
<i>Content Framework</i> .....	<b>198</b>
<i>Units</i> .....	<b>199</b>

# Introduction

Dance is an integral aspect of a balanced physical education programme. It is unique in that its primary concern is with the expressive quality of movement and with the enjoyment and appreciation of aesthetic and artistic movement qualities.

Throughout our history dance has served many different purposes all of which are evident today.

Dance is perceived as a :

- *physical activity*
- *popular entertainment*
- *form of religious worship*
- *profession*
- *an art form*
- *social and recreational outlet.*

There are many styles of dance, - ballet, tap, jazz, folk, contemporary, ballroom, etc.

The idea that dance is an activity suited to girls and inappropriate for boys should be challenged. Strategies are needed to combat prejudice which is visible and pervasive. Positive attitudes to dance should be demonstrated by male members of staff, particularly male Physical Education staff. Content should be designed to challenge boys and girls. Lessons should be planned to ensure that all students have opportunities to achieve. Teachers need to consider whether dance should be taught to boys and girls in mixed or single sex classes.

Dance has a particular contribution to make to students with special educational needs. It provides an alternative language and a route for learning about themselves, others and the world about them.

The suitability and modification of activities within dance education should be considered carefully to ensure that effective learning takes place.

## **WHY DANCE?**

The dance syllabus makes a distinctive contribution to the education of all students in that it provides the potential to integrate physical, emotional and intellectual development. It enables the students to express themselves and to communicate with others in a social and cultural context.

Through dance students learn how to:

- *use their bodies skilfully and creatively*
- *develop their creativity and imagination*
- *use expressive movement as a means of communication*
- *encourage an awareness of others and sensitivity towards them*
- *analyse form and quality in movement*
- *derive aesthetic understanding through the creation of dance and the appreciation of dance works*
- *extend their musical education*
- *stimulate and heighten work in other areas of the curriculum.*

Dance can inform and illuminate other areas of the curriculum such as Music, Drama, Visual Art, Film, Literature and can interact with natural and built environments. Cross-curricular links can be made with subjects such as Geography, Mathematics, S. P. H. E. (Social, Personal and Health Education), Information Technology (I. T.), English and other languages.

# Overall Aims & Objectives

## **AIM**

*To provide a context for aesthetic and artistic experience and the opportunity to develop personally and physically through participation in dance in an enjoyable environment.*

## **OBJECTIVES**

- *To develop skilful, creative mastery of the body in a dance context.*
- *To enhance knowledge and understanding of dance as an aesthetic and artistic experience.*
- *To enrich personal and social development while interacting with others in a variety of structured contexts.*



# Teacher Guidelines

As with any physical education lesson a dance class has three main sections

## WARM UP

## MAIN THEME AND DEVELOPMENT

## COOL DOWN

*The dance lesson will:*

- *emphasise good body placement and alignment at all times*
- *begin with simple large muscle group movements and gradually build to more complex work*
- *always have a definite beginning and ending position*
- *be exact on directions, cues, counts and tempo*
- *work both sides of body equally, avoid beginning on the same side each time*
- *include repetition which is important for the development of movement memory*
- *emphasise continuous movement, not a series of static poses.*

### THE LESSON INTRODUCTION

Before the lesson begins, the students may be told:

- *what they are going to do*
- *why they are going to do it*
- *how this builds on what they've done before.*

### THE WARM UP

Every lesson must start with a warm up which consists of (i) physiological and (ii) psychological elements. The choice of specific activities for the warm up should be made bearing in mind the dance content which is to follow, the physical condition and age of the group and the working space.

#### PHYSIOLOGICAL ELEMENTS

- *Activities which raise the body temperature/pulse.*
- *Activities which mobilise the joints.*
- *Activities which gently stretch the muscles.*

#### PSYCHOLOGICAL ELEMENTS

- *Provide the teacher with the opportunity to access the general mood of the group and to get the group in the mood for dance.*
- *Help the group to become comfortable with the space and to use it wisely.*

### MAIN THEME/ACTIVITY AND DEVELOPMENT

The teacher chooses movement tasks which relate to the main theme of each lesson e.g. in unit 1. (Creative Dance), the movement aim is concerned with the Basic Body Actions and the movement tasks include skipping, balance, stretch and sink whilst in unit 1 (Folk Dance), the concern is with rhythmic structures and the movement tasks are focused on the basic gallop step.

### THE COOL DOWN

After strenuous activity the muscles and cardiovascular system need to return to normal. Students should continue a slow activity until their breathing and heart rate are normal. During this time, students and teachers can reflect on the lesson of the day and on what has been learned.

# Teacher Guidelines: Creative Dance

## THE STRUCTURE OF THE DANCE LESSON

The educational significance of dance on the curriculum is determined by its potential to involve the student in:

**CREATING  
PERFORMING  
APPRECIATING**  
movement in aesthetic and artistic contexts.

Many approaches may be used in order to achieve the movement aims of the lesson. The student is encouraged to move by responding to a variety of stimuli and accompaniment and to view dance performance.

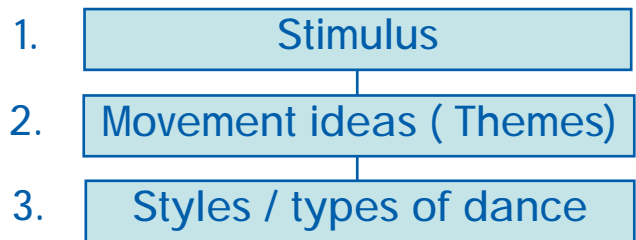

### 1. **STIMULUS**

If a stimulus is to be used, it should be considered as a starting point to encourage a dialogue between teacher and students. Careful selection is necessary to ensure that the stimulus heightens movement awareness, does not become restrictive and does not dominate the dance class.

#### STIMULI USED IN UNITS 1 — 6

- Unit 1 - Word charts
- Unit 2 - The skeleton
- Unit 3 - Circulation — The blood
- Unit 4 - Volcano
- Unit 5 - Hieroglyphics
- Unit 6 - Sculptures

### 2. **MOVEMENT IDEAS/THEMES**

Movement ideas/themes refer to the materials to be explored and developed. When considering selection of material for the dance lesson, the movement ideas are of primary importance.

#### MOVEMENT IDEAS USED IN UNITS 1 — 6

- Unit 1 - Developing an awareness of basic body actions
- Unit 2 - An awareness of body joints
- Unit 3 - An awareness of body surfaces (body)  
An awareness of shape (space)  
An awareness of time (dynamics)
- Unit 4 - An awareness of body actions with body parts leading.  
An awareness of weight transference
- Unit 5 - An awareness of shape in space  
An awareness of levels and directions in space.
- Unit 6 - An awareness of body shape  
An awareness of body action.

When planning these exemplar lessons attention may be given to some of the following elements.

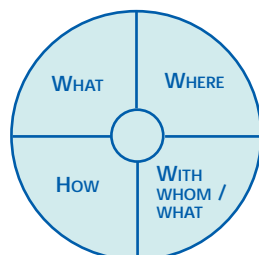

### 3. STYLES / TYPES OF DANCE

---

The styles/types of Creative Dance may be; abstract, comic dramatic, lyrical etc.

#### STYLES/TYPES USED IN UNITS 1 — 6

Unit 1	-	Abstract
Unit 2	-	Dramatic or Comic
Unit 3	-	Lyrical
Unit 4	-	Dramatic
Unit 5	-	Abstract
Unit 6	-	Abstract <i>Exploration, Experimentation and Improvisation</i>

To improvise is to compose without preparation or forethought or on the spot, without being directed. The students move in ways that they believe best tell their feelings or story. Improvisation can also result from listening to the music and reacting from within.

- **The warm up**

Select a warm up which is appropriate to the movement theme of the lesson and presented in a dance context with rhythm and phrasing.

- **Development**

The teacher should choose movement tasks which involve creating, performing and appreciating. These tasks must be linked to the idea/theme of the lesson and a directed or guided discovery method may be used by the teacher.

- **Select and refine movement**

When students have explored the theme they should be encouraged to select, clarify and refine their movements by making them clearer and sharper with a clear beginning, middle and end.

#### FURTHER DEVELOPMENT

---

These initial movement phrases from Units 1 — 6 may be further developed by selecting from the following: -

##### WHAT = BODY ACTION

Repeat the same phrase using the same body parts twice or maybe three times.  
Change the body part used to make the action e.g. use an elbow instead of head.  
Add one or more body actions into the phrase e.g. turn, gesture, jump etc.  
Stillness should be added appropriately.

##### WHERE = SPACE

Make the phrase bigger or smaller .  
Change the direction of the phrase.  
Using general space add a travel to the phrase following a different floor pattern.  
Change the level of the phrase.

##### HOW = DYNAMICS

Repeat the phrase using the same dynamics.  
Change the flow — bound — free.  
Change the speed — slow — quick.  
Change the power — strong — light.

##### WITH WHOM/WHAT = RELATIONSHIPS

Repeat the actions in the phrase in the same order.  
Change the order of the actions in the phrases.  
Reverse the order of the actions in the phrases.  
Perform the phrase as solo or with others.

If working in 2's some of the following formations can be used:

Side by side  
One behind the other  
Back to back  
Side by side, facing opposite directions  
Diagonally spaced, facing the same direction  
Diagonally spaced, facing opposite directions.

If working in-groups some of the following formations can be used:

Circle facing outwards  
Circle facing inwards  
Lines facing the same way  
Arrowhead  
Line (following a leader)  
Clump  
Scattered.

## SAFETY TIPS

Stress the following safety practices during all warm up and dance activities.

- *When doing knee bends (pliés) keep knees over the toes.*
- *When doing any kind of jump, start from bent knees (plié) and land with bent knees (in plié).*
- *Align the spine properly in every exercise. Avoid a hyper extended back or a forward thrust pelvis.*
- *Make sure shoulders are relaxed and pulled down (avoid hunching by shortening the neck).*
- *Students should wear appropriate clothing. Jewellery should be removed and long hair should be tied back.*

## DANCE APPRECIATION, OBSERVATION & ASSESSMENT

To dance is to move more precisely and exactly than in everyday life. Students are required to be fully focused and involved in the movement. It is important to be clear on when students should begin to move and when to stop. Movement phrases should have a clear beginning, middle and end.

Viewing and observing dance both during the developmental process and at the end of the final stage is an integral part of the student's dance appreciation.

It is through regular observation and discussion that understanding and knowledge develops. Students should be encouraged to view live or videotaped dance performances. During the performance the student viewing the dance piece should focus on the individual dancers, individual dance phrases and the performance as a whole.

Students should be encouraged to view what has worked satisfactorily and well in the composition.

This includes:

- *attending to the task*
- *involvement with the movement*
- *clear and definite phrases*
- *movement content relevant*
- *was there variety in the action content?*
- *was there development through repetition or spatial or dynamic qualities?*
- *was it danced with technical accomplishment?*

Teacher observation, as a form of assessment, is particularly appropriate for dance.

Assessment is best undertaken as the students are engaged in the activities.

Students need the opportunity to express how they feel about a dance piece whether it is a piece created and performed by professionals or by themselves or their peers.

They should be able to:

- *demonstrate observation skills*
- *recall a sequence of movements*
- *focus on a task and give positive input*
- *apply decision making skills.*

Oral assessment, through discussion and analysis of the students own work and the work of other students, will assist in the assessment process.

# Creative Dance



Choose to Dance

The Skeleton

Circulation

Volcano

Hieroglyphics

Sculptures

Level  
One

Creative dance is concerned with evolving rhythms and patterns of movement which can symbolise or represent human activity. It can spring from anything in human experience but the 'expression' is always in terms of movement. A dancer uses rhythms and shapes in the same way that a painter might use colours and textures.

## Learning Outcomes

The student will:

- *develop knowledge, understanding, and skills of creative dance*
- *plan, compose, perform, extend, and refine movements in creative dance contexts*
- *perform phrases showing control and sensitivity to the style of the dance and to the music and/or accompaniment*
- *perform short phrases which include a clear beginning, middle and end*
- *explore and compose movement motifs/phrases with clarity*
- *co-operate in-groups to discuss, select and perform phrases.*

## Content Framework

	<i><b>THEME</b></i>	<i><b>FOCUS</b></i>
<i><b>UNIT 1</b></i>	<i>Choose to Dance</i>	<i>Basic body actions</i>
<i><b>UNIT 2</b></i>	<i>The Skeleton</i>	<i>Body joints</i>
<i><b>UNIT 3</b></i>	<i>Circulation</i>	<i>Body surfaces, shape and time</i>
<i><b>UNIT 4</b></i>	<i>Volcano</i>	<i>Body parts and weight transference</i>
<i><b>UNIT 5</b></i>	<i>Hieroglyphics</i>	<i>Shape in space Levels and directions in space</i>
<i><b>UNIT 6</b></i>	<i>Sculptures</i>	<i>Body shape Body action</i>

Unit 1: Choose to Dance

**LEARNING OUTCOMES**

- The student will :**
- develop an awareness of the five basic body actions
  - develop an awareness of movement phrases
  - develop an awareness of what the body can do in an expressive manner.

**RESOURCES**

Student with pencil and paper, audio tape player/CD player, 4 tapes for individual unit (pop, classical, film theme), charts for this unit, basic body actions.

**CLASS ORGANISATION**

General space, personal space

STAGE	CONCEPT	CONTENT / ACTIVITY	TEACHING POINTS
<p><b>Warm up</b> Music: Portsmouth (Mike Oldfield)</p>	<ul style="list-style-type: none"> <li>• To focus &amp; centre the body</li> <li>• To mobilise &amp; warm the body</li> </ul>	<p>Skip: in different directions forwards x 8 counts/4 counts/ 2 counts backwards x 8 counts/4 counts/ 2 counts sideways x 8 counts/4 counts/ 2 counts</p> <p>Travel: small skips on toes Travel: using large skips Travel: using other ways of travelling e.g. gallop hop leap</p>	<ul style="list-style-type: none"> <li>• Focus on body alignment</li> <li>• Focus on use of space</li> <li>• Be aware of softness on landing</li> <li>• Focus on awareness of the ankle, flexing, extending</li> <li>• Focus on lower weight for large skips.</li> </ul>
<p><b>Development</b></p>	<ul style="list-style-type: none"> <li>• Exploration of movement</li> <li>• Phrase one word and progressively add others</li> </ul>	<ul style="list-style-type: none"> <li>• Select one word from each of the word groups - six words</li> <li>- Add one word from the Elevation chart</li> <li>- Prepare a movement phrase using these two words</li> <li>- Continue in this manner, until all the chosen words have been added to the phrase</li> <li>• Practice and memorize phrase</li> </ul>	<ul style="list-style-type: none"> <li>• Students should write out chosen words</li> <li>• Students must have a definite start and finish</li> <li>• There should be a preparatory stillness at start of phrase</li> <li>• There should be a held stillness at end of movement</li> </ul>
<p><b>Conclusion</b> Music: • A pop piece (Boom, Boom, Boom) • A classical piece (Pacabel, Carmen) • A film theme (Star Wars)</p>		<p>Divide into 4 groups. Each group selects a tape and performs their movement phrase to the music.</p>	<ul style="list-style-type: none"> <li>• Note how music changes the dynamic of the dance phrase</li> <li>• Encourage sensitivity to the music</li> <li>• Invite observation and discussion on work</li> </ul>
<p><b>Cool down</b></p>	<p>Slow, sustained concentrated movement. Awareness of transference.</p>	<p>Step close, step close to right. Repeat to left. Circle, both arms, small knee bend. Start with small transference and gradually enlarge movement.</p>	<ul style="list-style-type: none"> <li>• Consideration should be given to the quality of continuity in the movement phrase</li> <li>• Focus on the movement of transference of weight from one foot to the other</li> <li>• Focus on alignment</li> </ul>

Unit 1: Chart 1 Basic Body Actions

TRAVEL	ELEVATION	STILLNESS
Run Gallop Dart Roll	Leap Bounce Spring Skip	Freeze Pause Balance Hold
GESTURE	TURNING	TRANSFERENCE OF WEIGHT
Stretch Shrug Wave Sweep	Spin Rotate Coil Stir	Sway Overbalance Collapse Sink

Note: Teacher/students should feel free to add to this basic body action chart.



## Unit 2: The Skeleton

### LEARNING OUTCOMES

#### Body joints and travelling

#### The student will:

- gain an awareness of movement through the joints
- be introduced to movement phrases.

### RESOURCES

Pictures and/or models of the skeleton, poems about the skeleton.  
 Music: In dulcior Jubelito or 2nd rendezvous, Jean Michel Jarre

STAGE	CONCEPT	CONTENT / ACTIVITY	TEACHING POINTS
Warm up	Body Alignment	Walk for 8 counts change direction - 4 times Walk for 4 counts change direction - 4 times Walk for 2 counts change direction - 4 times Try this leading with right foot - change leading with left foot	Being aware of the surfaces of the foot as they make contact with the floor. Sensing the skeletal structure softness through the joints.
Exploring the idea		Walk for 8 counts, choose a joint, point it to the floor/ceiling/teacher, etc. Repeat, using different joints. Using one joint, find how many ways you can move it, e.g. the shoulder can move forwards/backwards/up/down and around Experiment with other joints, find still positions that draw attention to that part of the body, that make it noticed Travel for 8, focus on chosen joint for 8 or move the joint for 8 counts Explore different ways of travelling Move 2, 3, 4, hold 6, 7, 8. Repeat with knees, elbows and ankles	Emphasise clarity of placement of joints. Emphasise the whole body structure - how it related to chosen joint, what is the opposite joint doing?
Development Music: Rendezvous	<b>Suggested Progression:</b> Partner Work (a) copy or mirror each other (b) question and answer dance. Emphasise sensitivity and awareness of each other.	<b>Task 1:</b> Select a travelling phrase for 8 counts and a joint phrase for 8 counts. <b>Task 2:</b> Select a starting position, repeat phrases 3 times and select a finishing position.	Emphasise quality of movement. Change the phrase by using a different body joint, changing the method of travelling, adding one of the body actions (jump, turn, step, gesture, stillness, transference of weight). Have they travelled clearly? Have they shown clarity and focus on their chosen joint? Have they a clear beginning and end?
Conclusion		Travel to a partner, perform own phrases together and hold. Observation: half the class observe, while others perform.	
Cool down		Walk into circle. Reach a body joint into circle, melt out and walk back out. Repeat x 3.	Emphasise alignment and breathing.

Unit 3: The Blood

Movement idea / theme

The student will:

- develop travelling with an awareness of time
- develop an awareness of body surfaces and shape.

LEARNING OUTCOMES

RESOURCES

Word charts, brainstorm, word list, pictures  
 Music: Heartscore/Daghdha / Pulstar (Vangelis)  
 Oxygene: Jean Michel Jarre

STAGE	CONCEPT	CONTENT / ACTIVITY	TEACHING POINTS
Warm up		Walk, weaving in and out between each other, using the whole space. Teacher calls different types of travel, e.g. gallop, skip, jog. Travel fast, change to travelling slowly on signal from teacher.	Emphasise body alignment, soft legs, centre of gravity. Teacher directs rhythmic phrase e.g. through use of percussion/voice.
Exploring the ideas		<p><b>Circulating</b>  <b>Task 1:</b> Repeat travelling but this time slowly using different parts of the body, e.g. sliding, rolling.  <b>Task 2:</b> Take some words from brainstorm, list and explore with different body surfaces.  <b>Task 3:</b> With a partner, make a shape which the other can move over, round, through and under. Change over so that you can both try.</p> <p><b>Clotting</b>  <b>Task 4:</b> Students jog lightly using whole area. When the teacher calls a number, that number of students must instantly make contact and remain still. Repeat with the teacher calling different numbers each time.</p>	<p>Suggest that students move as if in a slow-motion film, keeping the movements smooth. What body part is in contact with the floor?</p> <p>What surface is leading the movement?                      What surface is being used, or is nearest to the partner's shape?</p> <p>Use words like wrapping and clotting to encourage use of whole body. Varying parts used for contact (not only hands but large body parts too), will increase the range of experiences.</p>
Development		<p><b>Task 5:</b> One from each pair becomes A, the other B. A's remain still in their preferred shapes. B's rush in and out, choose when to slow down and begin to move under, over, through and round any of the A's in their path. On a signal from the teacher B's slow down into a still position and A's become the travelling group.</p> <p><b>Task 6:</b> A's choose when to slow down and finish in contact with one of the B group. The B person moves away and circulates whilst A remains in the same position until contacted by another B. The dance ends when everyone is still, in contact, in twos.</p>	Hold still positions until everyone is still.
Conclusion		<p>Half the A's with half of the B's demonstrate. Groups change.</p> <p>Suggested Progression                      (a) Lengthen phrase by using word(s) from list e.g. 'spurting' - sudden jumps.                      (b) The clotting section could be extended to form groups of any size or number where students have good observation skills and can see possibilities for making contact with more than one other person.</p>	<p>What body surfaces are used?                      What shapes is the body making?</p>
Cool down		Stand, bend knees slowly.	

Unit 4: Volcano

The student will :

- gain an understanding of body parts and transference of weight
- gain an understanding of elevation.

### RESOURCES

Poems about volcanos, descriptive accounts.  
Brainstorm students for word ideas: flow, erupt, melt, solidity.  
Teacher should prepare own resources, e.g. chart.

STAGE	CONCEPT	CONTENT / ACTIVITY	TEACHING POINTS
<p>Warm up Music: Inishere</p>		<p><b>Introduce action words</b> - erupt, melt, bubble, flow, engulf, solidify <b>Set Study:</b> Stand, feet apart - roll down and up. Roll down onto hands, push back to feet, roll up 8 counts. Roll down, slide forward, onto trunk, push back to kneeling position and sit on heels, reach right arm forward, roll onto back, continue over onto knees. Repeat to left. Up to standing and repeat.</p>	<p>Head tucked in. Feel the weight of the head take the spine down, vertebra by vertebra, knees soft, feel weight transfer to hands and trunk. Tuck bottom in to come up. Smoothly transfer weight onto arm and side, soft tucked roll over, knees close to chest.  Note: stress safety aspect of the set study.</p>
<p>Exploring the ideas Music: the Monster Movie</p>		<p><b>Task 1:</b> Erupt and melt: Start near to the floor and spring to land on another part of the floor. On landing, let the body sink very slowly into the floor. <b>Task 2:</b> Experiment with different parts of the body leading the explosion <b>Task 3:</b> Bubble: make the body rounded and jump with your back leading the action, to represent the lava bubbling up. <b>Task 4:</b> Explore bubble action with smaller body parts <b>Task 5:</b> Flow: imagine that the parts of the body touching the floor are firmly fixed there. Pull slowly and strongly against these points of contact and travel by letting other parts of body sink down and repeat the process. <b>Task 6:</b> Engulf and solidify: experiment with moving towards a partner and wrapping yourself around them. Partner moves out and tries the action on you whilst you retain the shape.</p>	<p>Teaching points: ask students to try to make the body stretched or spiky whilst in the air sink into the floor should be done as if melting. Landing with feet wide apart will help students to gain control.  Teacher checks the back is rounded and leads the action.  The action should be slow and powerful.  Students should use a variety of different ways of enclosing their partner's shape.</p>
<p>Development</p>		<p><b>Phrase</b> - jump - melt - bubble - flow <b>Task 7a:</b> alone perform 3 of the erupting jumps and melt to the floor. <b>Task 7b:</b> include three bubbling jumps in this sequence. <b>Task 7c:</b> with a partner engulf and solidify as before. <b>Task 7d:</b> tasks 7a, 7b are performed alone and join with partner to perform 7d. Dance is practised.</p>	
<p>Conclusion</p>		<p>Half of the class observe while the other half perform. <b>Suggested progression:</b> students suggest other words which might inspire other movement ideas, trembling, hissing etc.</p>	
<p>Cool down</p>		<p>Opening set study or breathing exercise e.g. step and close, plie position, arms down in front, with circular movement lift the arms up over the head whilst raising up on to the toes. Plie as you bring the arms down in front.</p>	

Unit 5: Hieroglyphics

The student will:

- focus on shape in space
- symmetry and asymmetry with use of directions, levels and travelling

LEARNING OUTCOMES

RESOURCES

Tape recorder, tapes, love letter from King Tut-Ark-Amen (Mahmond Faddl), The Music of the Nile (Charcoal gypsies), general space and personal space, pictures from Egypt.

STAGE	CONCEPT	CONTENT / ACTIVITY	TEACHING POINTS
<p>Warm up Tamborine / Teachers</p>		<p>Run and on signal hold one of the following shapes: tall/narrow, wide, rounded/curved, twisted. Repeat. Change base to take shape.</p>	<p>Be aware of the base and extremities in relation to centre.</p>
<p>Development</p>		<p><b>Task 1:</b> make shapes using parts of the body to make following bases elbow / head / knee, + 2 shoulders 2 feet, 1 hand / 2 feet / 1 knee. <b>Task 2:</b> find ways of getting into and out of 2 bases. <b>Task 3:</b> from pictures select 3 shapes, mould into a continuous phrase. <b>Task 4:</b> develop by change of level, direction, add turn etc.</p>	<p>Clarify which shapes are symmetrical and asymmetrical. Make sure bases are clarified.</p>
<p>Conclusion</p>		<p><b>In threes:</b> <b>Task 5:</b> perform your own phrase at the same time as your partners. <b>Task 6:</b> 2nd time add pauses and small pieces learned off each others phrases. <b>Task 7:</b> repeat task 6 varying use of canon and unison. <b>Task 8:</b> observation.</p>	<p>Explain canon. Explain unison.</p>
<p>Cool down Music: Women of Ireland (Mike Oldfield)</p>		<p>Move slowly from a tall narrow shape into a wide shape, into a rounded/curved shape, into a twisted shape.</p>	

Unit 6: Sculptures  
**The student will:**

- develop mastery of technical set study
- develop an awareness of body shape
- develop awareness of body in space.

**LEARNING OUTCOMES**

**EQUIPMENT**

Tape, tape recorder, visual stimuli, pictures: celtic, sculptures, myth

**CLASS ORGANISATION**

Music: Sharon Shannon: Out the Gap, Enya: The Celts

STAGE	CONCEPT	CONTENT / ACTIVITY	TEACHING POINTS
<p><b>Warm up</b>                      Out the Gap,                      Sharon Shannon</p>	<p>Mastery of rhythm                      Focus on phrasing</p>	<p><b>Phrase 1</b>                      Walk forward x 4 hands to 'wheel' forward 4 counts.                      Walk backward x 4 hands to 'wheel' backward 4 counts.                      Throw left arm over to high right 4 counts.                      Roll body back to centre, arm head leading 4 counts.</p> <p><b>Phrase 2</b>                      Step to right – slide left leg under to change level to the ground.                      Roll over to diagonal line. Brush arms to toes &amp; rise to sitting.                      Place hands on right hand side turn onto front.                      Lift left leg over right &amp; continue turning to stand.</p>	<ul style="list-style-type: none"> <li>• Soft flowing continuous movement.</li> <li>• Repeat phrase 1 as often as necessary.</li> </ul> <ul style="list-style-type: none"> <li>• Slide onto side of leg softly to ground.</li> <li>• Be conscious of alignment.</li> <li>• Keep head dropped &amp; roll up to standing.</li> </ul>
<p><b>Development</b></p>		<p>Select any 4 different Celtic Pictures.                      Select a shape from each picture.                      Copy each shape in turn with the body.                      Explore ways of linking each shape.                      Suggest change of level, change direction, make shape bigger &amp; smaller.                      Link set study to phrase.</p>	<ul style="list-style-type: none"> <li>• Shapes one &amp; four will form beginning and end of phrase in stillness.</li> </ul> <p><b>Development option:</b></p> <ul style="list-style-type: none"> <li>• Select only 1 phrase of set study &amp; link to new shape phrase.</li> <li>• Select all set study and add own phrase.</li> <li>• Perform shape phrase in travelling manner.</li> </ul>
<p><b>Conclusion</b>                      The Celts, Enya</p>		<p>In groups of four, students copy each others phrases.                      Each group performs set study and phrases.</p>	<p>N.B. Students do not learn each others phrases.                      They copy as each student performs.</p> <ul style="list-style-type: none"> <li>• Focus on continuity, sensitivity and quality of movement.</li> </ul>
<p><b>Cool down</b></p>		<p>Move in a sustained manner into and out of four chosen Celtic shapes.</p>	

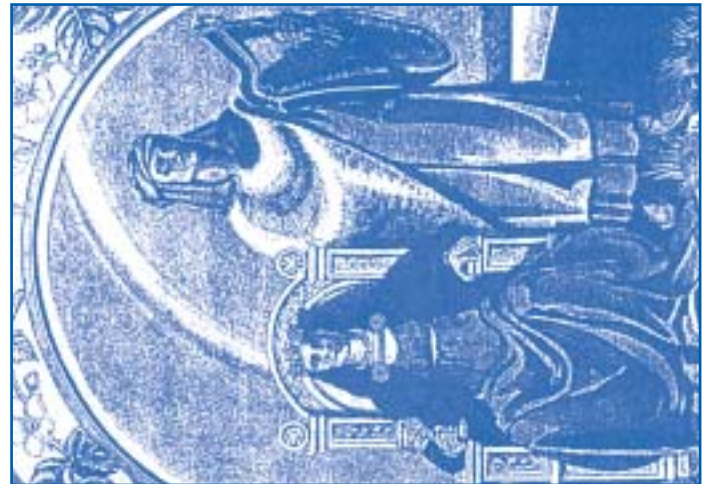

# Folk Dance



Clap Dance (Germany)

Syphspring (Denmark)

Walls of Limerick (Ireland)

The Hazelnut (Balkan Countries)

The Vleegard (Holland)

The Mexican Waltz (Mexico)

Level  
One

Folk dances are recreational dances that have been passed on from generation to generation. The inclusion of folk dancing in the curriculum should be encouraged as part of the countries cultural heritage. The primary purpose of folk dance is participation. Folk dance is built around basic co-ordination, simple locomotor, movement sequences and uncomplicated dance steps. Folk dance includes circle and line dances, single partner, mixed partner, individual dances and group performance dances.

## Learning Outcomes

The students will:

- *develop knowledge, understanding, and skills of folk dance.*
- *develop a basic rhythmic competency*
- *develop creativity through changes in floor pattern and group formation*
- *perform short dances including dances from different traditions*
- *enhance their awareness of the cultures the dances represent*
- *describe, analyse and interpret dances recognising differences.*

## Content Framework

<b>Unit</b>	<b>1</b>	-	Clap Dance (Germany) Line or circle formation Couples Dance. Step — Gallop
<b>Unit</b>	<b>2</b>	-	Syphspring (Denmark) Large circle. No partners required. Step — Skipping and walking.
<b>Unit</b>	<b>3</b>	-	Walls of Limerick (Ireland) Progressive Dance. Partners. Step — Hop, 1, 2, 3. (Jig)
<b>Unit</b>	<b>4</b>	-	The Hazelnut (Balkan Countries) Circle Dance, No partners required. Step — side step.
<b>Unit</b>	<b>5</b>	-	The Vleegard ( Holland) Square set. Partners. Step — Gallop
<b>Unit</b>	<b>6</b>	-	The Mexican Waltz (Mexico) Line Dance. Partners Step — Waltz step.

Students may be asked to define culture and describe the components that make up a culture, such as religion, environment, diet and customs.

Folk dance lends itself to creativity, through changes in floor pattern and group formation. Teachers may include this idea into each folk dance, as they wish. Do not lose the characteristic of the folk dance. It is suggested that teachers isolate the various components of the dance and work on individual sections, before introducing the complete formation.



## Unit 1: The German Clap-Dance

### LEARNING OUTCOMES

- The student will:
- become aware of a simple rhythmic structure
  - will learn a simple folk step - the gallop.

### RESOURCES

Tape recorder, tape music.

### CLASS ORGANISATION

Line formation, couples stand facing each other.

STAGE	CONCEPT	CONTENT / ACTIVITY	TEACHING POINTS
Warm up Music Portsmouth		Skip: in different directions. forwards x 8 counts / 4 counts / 2 counts backwards x 8 counts / 4 counts / 2 counts sideways x 8 counts / 4 counts / 2 counts alternate gallop & skipping steps.	
Development		<p><b>Task 1:</b> clap sides, together, partner's right hand. clap sides, together, partner's left hand. clap sides, together, right then left. clap sides, together, both hands together (repeat).</p> <p><b>Task 2:</b> catch partner's hands, gallop 7 steps sideways. click feet together (repeat in opposite direction).</p> <p><b>Task 3:</b> clap sides, together, right foot, which is raised to side. clap sides, together, left foot which is raised to the side. clap sides, together, both feet (repeat).</p> <p><b>Task 4:</b> repeat Task 2</p>	<ul style="list-style-type: none"> <li>• Students face teacher to learn rhythmic clapping phrase.</li> <li>• "Together" clap hands together.</li> <li>• Arms extended.</li> </ul>
Conclusion Music: German Clap Dance		<p><b>Task 5:</b> in 2's change formation of gallop e.g. gallop away &amp; towards each other. <b>Suggested progression:</b> perform the dance in a circle.</p>	<ul style="list-style-type: none"> <li>• No words.</li> <li>• Practice without music.</li> <li>• Practice movement at correct tempo.</li> <li>• Perform with music.</li> </ul>
Cool down Music: Oxygene Jean Michel Jarre		Walk around the room, find a shape & lie on floor, stretch the whole body, hold for 4 counts, release for 4 counts. Repeat.	

Unit 2: Syvspring Denmark

**LEARNING OUTCOMES**

- The student will:**
- become aware of a simple rhythmic structure
  - become aware of level changes within folk dance
  - perform a simple skipping step
  - maintain balance while changing level.

**RESOURCES**

Tape/CD deck, appropriate music—Syvspring Tempo 1 and/or Syvspring Tempo 2

**CLASS ORGANISATION**

Formation: large circle: alternate boys and girls.

STAGE	CONCEPT	CONTENT / ACTIVITY	TEACHING POINTS
Warm up		<ol style="list-style-type: none"> <li>1. Select a skipping step skip forwards, backwards, sideways.</li> <li>2. Point right foot, point left foot. Repeat 1 and 2.</li> </ol>	
Development		<ol style="list-style-type: none"> <li>1. Skip clockwise for 16 bars.</li> <li>2. Walk back for 16.</li> <li>3. Point right foot. Repeat 1 and 2.</li> <li>4. Point right foot/left foot. Repeat 1/2.</li> <li>5. Point right foot/left foot / kneel right knee. Repeat 1 and 2.</li> <li>6. Point right foot/left foot / kneel right knee / left knee. Repeat 1 and 2.</li> <li>7. Point right foot / left foot / kneel right knee / left knee / right elbow on ground. Repeat 1 and 2.</li> <li>8. Point right foot / left foot / knee / right knee / left knee / right elbow / left elbow on ground. Repeat 1 and 2.</li> <li>9. Point right foot / left foot / knee / right knee /left knee / right elbow / left elbow on ground / forehead on ground. Repeat 1 and 2.</li> <li>10. Point right foot / left foot / kneel right knee / left knee / right elbow / left elbow on ground / forehead on ground.</li> <li>11. All rise to knees and raise hand to ceiling and shout "Scholl".</li> </ol>	<ul style="list-style-type: none"> <li>• Isolate components of dance &amp; teach separately.</li> <li>• Work without music before introducing the dance formation.</li> </ul> <p>Syvspring Tempo 1 is at a slower tempo (beat) and phrase A has 8 skips and 8 walks with 3 beat introduction to start of beat. Syvspring Tempo 2 is quicker beat and phrase A has 16 skips and 16 walks with 'no' introduction e.g. 'and' skip.</p>
Conclusion		<p><b>Two Circles</b> Walk in opposite directions for 16 counts. Perform a stretching exercise with a partner. Repeat x 8 x 4 x 2 counts.</p>	Teacher provides 4 stretching exercises.

Unit 3: The Walls of Limerick (Ireland)  
**The student will :**

- accomplish the rhythmic patterns of the dance
- be introduced to a progressive dance.

**LEARNING OUTCOMES**

**RESOURCES**

Tape/CD player, music for Walls of Limerick.

**CLASS ORGANISATION**

Progressive dance.

**STAGE**

**CONTENT / ACTIVITY**

**TEACHING POINTS**

Warm up

**Task 1:** stepping on the spot and clapping to the music.  
**Task 2:** stepping on the spot x 8. Stop. Clapping x 8.  
**Task 3:** walking to a new spot x 8 clap and step on the spot x 8.

Step softly on feet. Knees and ankles softened (not pounding). Listen to the rhythm of the music.  
 Watch body alignment, i.e., body erect, no slouching.

Development

**Dance 1: The Walls of Limerick**  
**Task 1:** introduce the 1,2,3, rhythm: clap 1, 2, 3 x 8 step (on the spot) 1,2, 3 x 8.  
**Task 2:** repeat, travelling forwards and backwards.  
**Task 3:** introduce hop 1,2,3.  
**Task 4:** introduce the side step walk to the left keeping left foot in front, walk to the right keeping right foot in front. (Repeat on right & left foot). Introduce hop 2,3,4,5,6,7,  
**Task 5:** full side step with the 1,2,3's.  
**Task 6:** introduce formation of the dance—"advance and retire". Ladies cross to each others place. Boys cross to each others place. Walk with opposite partner out to the sides and return. Walk around with own partner.

Keep body facing forward.

Keeping in time to the music.

Be very aware of which foot the weight is on when learning the hop 2,3. Practise the hop 2, 3 slowly at first.

The Walls of Limerick is the simplest of all dances from the point of view of execution. At starting, the dancers line up in couples, girl on boy's right, each set of two couples facing each other. It is danced to reel-time, and consists of four movements as follows:

This is only the floor pattern walk only. Girl on the right of boy. Walk forward, walk back x 2. 2 opposite 2 Right shoulder leading in cross overs.

**Task 7:** repeat formation using appropriate dance steps.

**Task 8:** introduce 'progression'.  
 Take right hand to the sides.  
 Walk a circle, anti-clockwise around opposite circle.  
 Advance and retire using 1,2,3's. Cross over using side step.  
 Out to sides using side step. Circle around using 1,2,3's.  
 After circling, couples must finish up facing the direction they started the dance in.

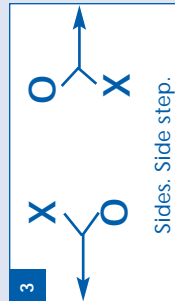
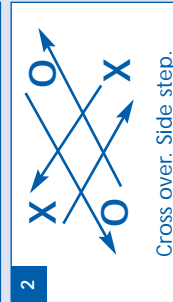
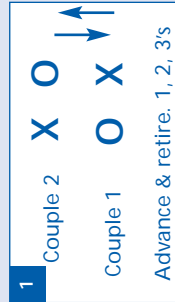

Conclusion

Walk around the room.  
 Walk into the centre, walk out to a space and repeat.

## Unit 4: The Hazelnut Dance (Balkan countries)

### LEARNING OUTCOMES

- The student will:
- accomplish the rhythmic pattern of basic steps
  - become familiar with a circle dance
  - be made aware of the country of origin.

### RESOURCES

Tape/CD player, tape music for Hazelnut Dance.

### CLASS ORGANISATION

Circle dance.

STAGE	CONCEPT	CONTENT / ACTIVITY	TEACHING POINTS																		
Warm up		Jog on your own x 8. Meet a partner and jog with partner x 8. Couple meet another couple and jog x 8. Separate & repeat.																			
Development		<p><b>Task 1:</b> students facing teacher they learn the steps.</p> <p><b>Step 1:</b> to the right</p> <table border="0"> <tr> <td>R</td> <td>L</td> <td>R</td> <td>L</td> <td>R</td> <td>L</td> </tr> <tr> <td>Step</td> <td>close</td> <td>step,</td> <td>close</td> <td>step</td> <td>stamp</td> </tr> <tr> <td>R =</td> <td>right</td> <td>foot</td> <td>L =</td> <td>left</td> <td>foot</td> </tr> </table> <p>Repeat same pattern starting on left foot. Repeat all of step 1.</p> <p><b>Step 2:</b> step right, stamp left - Step left, stamp right. Step right, stamp, stamp (left). Repeat step 2 once more.</p> <p><b>Task 2:</b> formation: full circle. Hands resting on neighbours shoulders. Steps are repeated continuously and get progressively faster in response to the music.</p> <p><b>Task 3:</b> in 2's explore possible, relationship variations, e.g. dance side-side, back-to-back, forwards/backwards. Observe: partner work &amp; select one suitable as class activity.</p>	R	L	R	L	R	L	Step	close	step,	close	step	stamp	R =	right	foot	L =	left	foot	<p>Knees must be kept softened and not jarred on the stamp.</p> <p>Be aware and sensitive to partner relationship.</p>
R	L	R	L	R	L																
Step	close	step,	close	step	stamp																
R =	right	foot	L =	left	foot																
Conclusion		Repeat whole dance and include selected partner sequence.																			
Cool down		In group of 4 rise and sink slowly.																			

### Unit 5: The Vleegard (Holland)

#### LEARNING OUTCOMES

- The student will :
- perform a simple galloping step
  - be introduced to a square set
  - maintain balance while changing direction.

#### RESOURCES

Tape/CD player, music for the Vleegard.  
2 couples.

Formation: OX OX X O  
or X X X O  
(Square Set) XO XO

### CONCEPT

### CONTENT / ACTIVITY

### TEACHING POINTS

#### Warm up

- Gallop 2,3, and stamp left foot (right foot leading). Repeat left foot leading.
- Gallop 8 beats right foot, left foot leading.

#### Development

- Fig 1** All hands joined in circle  
Partners acknowledge each other.  
Partners acknowledge corner partners.  
Repeat to partners and corners.  
All move to left with 7 gallop steps.  
Repeat whole to left but break circle and make square set at end of phrase.
- Fig 2** Waltz grip. Head couples advance towards each other with 4 gallop steps.  
Return to places with 4 gallop steps.  
Head couples cross over with 8 galloping steps, the men passing back to back.  
Repeat slips to centre and cross over back to original places.  
Side couples repeat.
- Fig 3** (Pass your partner on)  
Waltz grip. Head couples advance towards each other with 4 gallop steps.  
Return to places with 4 gallop steps.  
Head couples advance again towards centre, but separate and girls go on to opposite partners (by turning right shoulder back) whilst man gallops back to original place with new girl.  
Repeat gallops to centre and change back to original partners.  
Side couples repeat above.

Fig 1 and Fig 2 may complete dance.  
Fig 3 a further progression may be added if desired.

Formation may also be a Square Set of 6 couples or 8 couples.

#### Cool down

Stand with arms stretched out at shoulder level.  
Bring right arm down in a circular movement, sweeping the floor.  
Repeat with left arm.

Right arm draws a large circle in front of the body.

Unit 6: Mexican Waltz (Mexico)  
**The student will:**

- perform a simple waltz step
- be introduced to a progressive dance.

**LEARNING OUTCOMES**

**RESOURCES**  
 Tape player.

**MUSIC**  
 Mexican Hat Dance  
 Mexican Waltz

STAGE	CONCEPT	CONTENT / ACTIVITY	TEACHING POINTS
<p><b>Warm up</b>                      Music:                      Mexican Hat Dance</p>		<ol style="list-style-type: none"> <li>Two feet, bouncing on the spot x 4 in 4 directions.</li> <li>Step forward on the right foot, then on left foot (bringing both feet together) rise up on both feet and lower.                              Repeat with left foot leading.                              Step back on right foot, then on left, rise up on both feet and lower.                              Repeat with left foot leading.                              Repeat no. 2 above x 4 directions.</li> </ol>	<ul style="list-style-type: none"> <li>Soft knees.</li> <li>Focus on body alignment.</li> <li>Introduction to waltz rhythm.</li> </ul>
<p><b>Development</b>                      Music:                      Mexican Waltz</p>		<ol style="list-style-type: none"> <li>In a large circle, holding hands, sway in 2,3 and out 2,3. Each boy passes his left hand girl to his right side. All this is repeated four times (the boy stays in his place, the girl moves).</li> <li>The boy keeps the 4th girl on his right hand side and takes the waltz hold and they waltz around the circle x 8 bars.</li> <li>With partner, take both hands. Step in 2,3 and out 2,3 and dropping hands, each turns around on the spot.</li> <li>Repeat the complete dance.</li> </ol>	<p>Waltz hold:                      The girl places her right hand on boy's left hand, girl places her left hand on boy's right shoulder, the boy places his right hand under the girl's left shoulder blade.</p>
<p><b>Cool down</b>                      Music:                      "Women of Ireland"                      Mike Oldfield</p>		<p>Step, close, rise up onto toes and hold x 4, lower onto feet and bend the knees x 4 (plié).</p>	



- Invasion Games
- Divided Court Games

# Games

*invasion games court*  
*net games striking*  
*fielding games target*  
*games*





# CONTENTS



	<i>Page</i>
<i>Introduction</i> .....	<i>208</i>
<i>Teacher Guidelines</i> .....	<i>210</i>
<i>Overall Aim and Objectives</i> .....	<i>213</i>
<i>Level One</i> .....	<i>215</i>
<i>Learning Outcomes</i> .....	<i>216</i>
<i>Content Framework</i> .....	<i>217</i>
<i>Units</i> .....	<i>218</i>
<i>Level Two</i> .....	<i>233</i>
<i>Learning Outcomes</i> .....	<i>234</i>
<i>Badminton</i> .....	<i>235</i>
<i>Gaelic Football</i> .....	<i>241</i>
<i>Soccer</i> .....	<i>254</i>

# Introduction

## GAMES

The traditional model of teaching games is based on the acquisition of discrete sports skills and techniques which are then developed in the context of specific games. In the understanding approach which is recommended in this syllabus, the teaching of skill and technique takes second place to the development of tactical awareness through an exploration of principles of play.

We must recognise that the majority of students will not have the capacity to become highly skilled players, but they will all have the capacity to develop sufficient skill to play games at an enjoyable level. *'Much of the pleasure involved in games playing lies in making correct decisions in the light of tactical awareness'* (Thorpe and Bunker, 1982).

The teacher's task is to create the situation where the student seeks to develop skills which are required for him/her to perform in a given situation. Skill acquisition is seen in the context of the learner and the game situation - it arises from the game.

Students require a level of knowledge and understanding which will enable them to make the appropriate decisions based on their current level of awareness of the tactical situation. The teacher should provide the student with the knowledge-base which will enable him/her to develop problem-solving skills.

The main focus of the understanding approach to games teaching is on tactical awareness and decision making rather than on the development of skill and technique. This provides the opportunity for all the students, irrespective of physical ability, to play a central role in the games lesson, thus enhancing self-esteem and a sense of personal fulfilment.

Students are encouraged to play the game at their own technical level—ensuring a level of success and enjoyment for all.

The Games for Understanding Model views the teacher as an enabler rather than a transmitter of knowledge. It views the student as being responsible for his/her own learning rather than as a passive receiver of information. The model rejects the notion that there is one correct way which the teacher knows and must be transmitted to the students, rather, it views the teaching of games as a process of problem resolution. The teacher creates a situation where the student identifies the problem and then seeks tactical solutions. Thus the teacher, in deciding what to teach, instead of listing the skills and techniques of the various games, is required to look at the potential problems within the game situation.



# Categorisation of Games

Games can be categorised according to the format in which they are played. The four major categories are:

- INVASION GAMES**
- COURT/NET GAMES**
- STRIKING / FIELDING GAMES**
- TARGET GAMES**

All our major games fall into one of these categories (Table 1). The principles of play involved in a game are directly comparable to those games within the same category - thus, for instance, the principles of attack and defence appropriate to hockey will also apply to basketball. This should facilitate the carry-over of learning from one game to another.

A balanced games programme should include experience in each of the game formats.

Table 1: Categorisation of Games

<i>INVASION GAMES</i>	<i>NET / COURT GAMES</i>	<i>STRIKING / FIELDING GAMES</i>	<i>TARGET GAMES</i>
<i>FOCUSED GOAL</i> Gaelic Football Soccer Hockey Basketball Hurling Camogie Netball	<i>DIVIDED COURT</i> Badminton Tennis Volleyball Table Tennis	Rounders Cricket Baseball	Golf Bowls Archery
<i>LINE GOAL</i> Rugby American Football	<i>SHARED COURT</i> Squash Handball Racquetball		

Balance should also be aspired to in terms of the predominant skills involved in the game, i.e., striking skills, throwing / catching skills and kicking skills.



# Teacher Guidelines

## The Teaching for Understanding Model

The following model, proposed by Bunker and Thorpe (1982), outlines the procedure whereby the teacher helps the student to achieve a new level of skillful performance.

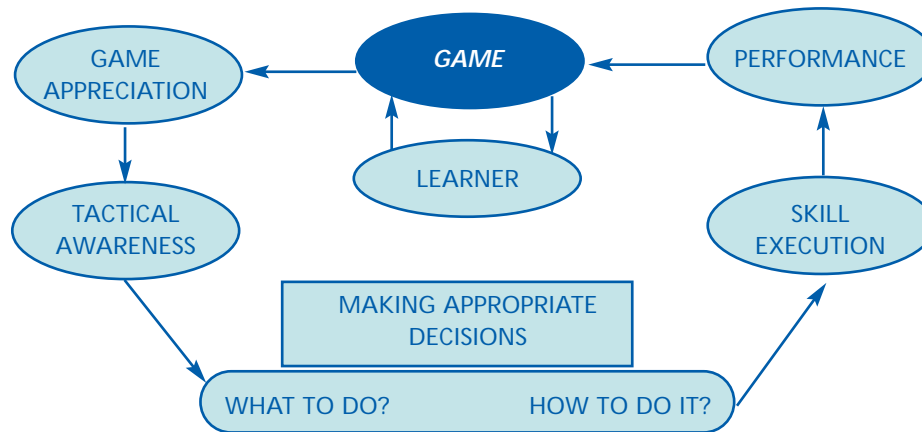

### 1. GAME

The lesson always commences with a game. The students are presented with a game which will probably involve small numbers of players, modified playing surface area and modified equipment. It is important that the students are capable, with guidance, of understanding the particular game form and are capable of playing it. They are guided to recognise the unique problems to be solved in playing the game.

### 2. GAME APPRECIATION

From the outset the students should understand the rules of the game being played. The rules should be simplified to ensure this. The imposition of certain rules will regulate the skill level and the tactics to be employed.

### 3. TACTICAL AWARENESS

Students are introduced to the tactics of the game through the gradual introduction of movement principles, based on simple ideas of space and time. By investigating and experimenting with these ideas in simple games the students are encouraged to progress to more advanced situations.

### 4. MAKING APPROPRIATE DECISIONS

Proficient games players take only fractions of a second to make decisions and they would see no value in distinguishing between the 'what?' and the 'how?'.

In the understanding approach the teacher separates the questions of 'what to do?' and 'how to do it?' to enable the student to recognise and attribute shortcomings in decision-making.

*'What to do?'* In deciding what to do each situation has to be assessed and thus the ability to recognise cues and predict possible outcomes is important.

*'How to do it?'* Having decided what to do the player then has to make a decision as to what is the best way to do it. he/she has to make the most appropriate response.

### 5. SKILL EXECUTION

In the model skill execution is used to describe the actual production of the required movement, as envisaged by the teacher. The model must be seen in the context of the learner and must recognise the learner's limitations. The execution of the correct skill becomes important only after the learner sees the need for that particular kind of skill.

When the student is ready for these skills technical instruction is given but it is always at a level commensurate with the student's current ability level.

### 6. PERFORMANCE

This is the observed outcome of the previous processes measured against criteria that are independent of the learner. It should be a measure of appropriate response as well as efficiency of technique. The teacher helps the student in deciding whether a performance is correct or incorrect and in making decisions about how to improve it.

### 7. GAME

The sequential aspects of the model are critical. Satisfactory completion of the stages as outlined will necessitate modification of the game leading to a re-appraisal of the requirements of the new game. The cycle begins again.

# Tactical Problems in Invasion Games

## ATTACKING PRINCIPLES

- Keeping Possession
- Depth
- Distribution of Possession
- Support
- Penetration
- Scoring
- Width
- Creating Space

Problem	Tactical Solution	On the Ball	Off the Ball
1. <i>How do we keep possession?</i>	<i>Keep the ball Pass the ball</i>	<i>Carry, Solo, Dribble Choose receiver Signal intention Pass the ball Practice deception</i>	<i>Move into space to get free for pass or to draw defender React to signal Give signal React to deception</i>
2. <i>How do we invade the territory?</i>	<i>Penetrate the defence Use width in attack Support the attack</i>	<i>Pass forwards Move forwards</i>	<i>Same as above and provide cover in depth</i>
3. <i>How can we score?</i>	<i>Create a space to shoot Attack the target  Set pieces / shots.</i>	<i>Take on a defender 1 v 1 Shoot / score</i>	<i>Draw out defender from target area Support in - width - depth</i>

## DEFENDING PRINCIPLES

- Tackling
- Closeness (width)
- Intercepting
- Support (depth)
- Concentration
- Defend target
- Deny space

Problem	Tactical Solution	On the Ball	Off the Ball
1. <i>How can we regain possession?</i>	<i>Win the ball</i>	<i>Tackle or intercept</i>	<i>Anticipate the pass</i>
2. <i>How can we stop invasion?</i>	<i>Close down space Close down player with the ball</i>	<i>Prevent passing forward by close marking Prevent moving forward by tackling</i>	<i>Support other defenders Stay close Stay on target side</i>
3. <i>How can we stop them scoring?</i>	<i>Deny shooting space Defend the target</i>	<i>Stay on target side Block striker Block the shot</i>	<i>Stay on goal side Maintain depth Cover angles Mark a player (person to person) or a space (zone)</i>

# Tactical Problems in Badminton

## ATTACKING PRINCIPLES

- Creating Space
- Shuttle Placement
- Deception
- Pressure
- Serve

## DEFENDING PRINCIPLES

- Denying Space
- Creating Time
- Regaining Control
- Return of serve

Problem	Tactical Solution	Action Taken
1. How do I win a point?	<p>Create space (using width and depth) to place shuttle on the ground.</p> <p>Force an error.</p>	<p>Keep opponent at the back of the court (a defensive position).</p> <p>Make the opponent run.</p> <p>Use deception to disguise your intention.</p> <p>Limit opponent's time by playing the shot low (drop-shot) or fast (smash).</p>
2. How do I serve?	<p>Long to forehand/backhand.</p> <p>Short to forehand/backhand.</p>	<p>Assess opponent's form and use a serve which exposes weaknesses taking account of own serve's strength.</p>
3. How do I prevent my opponent from scoring?	<p>Defend space on own court.</p> <p>Create time to recover.</p>	<p>Adjust position on court to limit opponent's options.</p> <p>Narrow the angles available to opponent.</p> <p>Keep the shuttle deep/high to create recovery time.</p> <p>React to deception.</p> <p>Anticipate play.</p> <p>Turn defence into attack, if possible!</p>

## Overall Aim & Objectives

### **AIM**

To provide students with the opportunity to develop personally, socially and physically through participation in a variety of games in a safe and enjoyable environment.

### **OBJECTIVES**

- *To motivate the students to develop the skills required for participation in games activities.*
- *To provide students with the knowledge and understanding which will enable them to make appropriate decisions based on their current level of tactical awareness.*
- *To provide the opportunity for all students to have an active role in the games lesson at their own technical level - thus enhancing self-esteem and sense of personal fulfilment.*







# Games



Level  
One

# Learning Outcomes

*The student will:*

- *show an appreciation of how games are formed and developed*
- *display a knowledge and understanding of basic principles and rules of invasion games*
- *demonstrate the ability to make appropriate responses (relative to their own abilities) to the particular problem posed by the game*
- *display an understanding of the dynamics of teamwork*
- *show an ability to modify games if improvements are necessary*
- *display an appreciation of the benefits which participation in games can bring*
- *display a level of success in games playing*
- *exhibit a sense of personal fulfilment*
- *assume responsibility:*
  - *for giving and following directions*
  - *by adhering to agreed rules*
- *contribute to group effort*
- *show respect for the rights, opinions and ability of others*
- *participate co-operatively in games activities*
- *maintain focus on task in hand*
- *show respect for equipment*
- *assist in setting up and putting away equipment.*



## CONTENT FRAMEWORK



The subject matter consists of a foundation games programme concentrating on the basic principles of play within invasion games.

### **Unit 1**

Games making.

### **Unit 2**

Games making.  
Communicating game principles between group.



### **Unit 3**

Problem solving.  
Decision making in game situation.

### **Unit 4**

Decision making.  
Use of possession.  
Teamwork.



### **Unit 5**

Team communication.  
Support.  
Strategies.  
Scoring.

### **Unit 6**

Application of learning to variety of games.  
Assessment.

## Unit 1: Games making

### LEARNING OUTCOMES

- The student will:
- identify and explore the various game classifications
  - create and demonstrate a game using specified guidelines.

### EQUIPMENT

Task cards, cones, variety of equipment - mats, beanbags, balls.

### CLASS ORGANISATION

Groups of various sizes.

STAGE	CONCEPT	CONTENT / ACTIVITY	TEACHING POINTS
<p>Warm up &amp; stretching</p> <p>Introductory activity</p>	<p>Warm up</p>	<p>4 v 4 games without ball.                      Pass by calling name.                      Gain possession by touching .                      Play before they call name.</p> <p><b>Score:</b> # of passes or 'pass' to player in score zone</p>	
<p>Development</p>	<p>Creating a game.</p> <p>Sharing ideas.</p> <p>Co-operating on task.</p>	<p>The students ,working in groups, are given a task card and the following guidelines to create their own game:                      The game should have:</p> <ul style="list-style-type: none"> <li>• a name</li> <li>• a set of rules</li> <li>• a scoring system</li> <li>• re-starts</li> <li>• specific techniques</li> <li>• possibility of specific roles (e.g.goalkeeper)</li> <li>• tactics.</li> </ul>	<p>Teacher organises group sizes and choice of equipment to encourage various game formats.</p> <p>The tasks can be presented to each group on cards.</p> <ol style="list-style-type: none"> <li>1. In groups of 2 devise a game using a small ball and wall (shared court).</li> <li>2. In groups of 4 devise a game using a net and a beanbag (divided court).</li> <li>3. In groups of 6 devise a game using a large ball and 4 cones (invasion game).</li> <li>4. In groups of 6, devise a game using a mat, a bollard, a bat, and 3 cones, with two teams (striking / fielding).</li> <li>5. With an uneven number, 5 / 7, devise a game using skittles / plastic bottles and a tennis ball (target game).</li> </ol> <p><b>Working area for each group should be sufficient for the task to be performed in safety.</b></p>
<p>Concluding activity</p>	<p>Organisation and communication of ideas.Cool down.</p>	<p>Demonstrate game to the rest of the class.                      Gentle jog around area.</p>	

## Unit 2: Games making (continued)

### LEARNING OUTCOMES

#### The student will:

- show an understanding of concepts and principles peculiar to different categories of games
- refine and demonstrate a created game.

### EQUIPMENT

Task cards, cones, variety of equipment - mats, beanbags, balls.

### CLASS ORGANISATION

Groups of various sizes.

STAGE	CONCEPT	CONTENT / ACTIVITY	TEACHING POINTS
Warm up & stretching	Warm up	Select from warm up resource materials.	
Introductory activity	Energiser	<b>Crab ball</b> (see resource materials).	
Development	Sharing ideas. Co-operating on set task.	The students, working in groups, are given a different task card to unit 1 and the following guidelines to create their own game: The game should have: <ul style="list-style-type: none"> <li>• a name</li> <li>• a set of rules</li> <li>• a scoring system</li> <li>• re-starts</li> <li>• specific techniques</li> <li>• possibility of specific roles (e.g. goalkeeper)</li> <li>• tactics.</li> </ul> Record game.	Teacher organises group sizes and choice of equipment to encourage various game formats. The tasks can be presented to each group on cards. <ol style="list-style-type: none"> <li>1. In groups of 2 devise a game using a small ball and wall (shared court).</li> <li>2. In groups of 4 devise a game using a net and a beanbag (divided court).</li> <li>3. In groups of 6 devise a game using a large ball and 4 cones (invasion game).</li> <li>4. In groups of 6, devise a game using a mat, a ballard, a bat, and 3 cones, with two teams (striking / fielding).</li> <li>5. With an uneven number, 5 / 7, devise a game using skittles / plastic bottles and a tennis ball (target game).</li> </ol> Working area for each group should be sufficient for the task to be performed in safety.
Concluding activity	Communicating. Instructing. Cool down.	Demonstrate game and teach to another group. One game may be taught to whole class. Jogging and stretching.	Importance of clarity of rules and tactics are to be explained and taught to peers.

Unit 3: invasion games

The student will:

- identify the basic concepts and problems inherent in invasion games
- demonstrate an ability to make appropriate decisions regarding what to do and how to do it re: a) keeping possession and b) creating space.

LEARNING OUTCOMES

EQUIPMENT

Ball(s), bibs, cones - ribbons / bibs for tails, cones, basket, circle drawn etc.

CLASS ORGANISATION

Basic: work in fours.

STAGE	CONCEPT	CONTENT / ACTIVITY	TEACHING POINTS
Warm up & stretching	Warm up	Select from warm up resource materials.	
Introductory activities	Energiser	<b>Keep your tail</b> (see resource materials).	Discourage rough play.
Development	<p>Invasion of space (width/depth/support/penetration) Appropriate attacking strategies. Working effectively as a team. Identifying and using appropriate defence strategies.</p> <p>Appreciating the importance of imposing rules and conditions. Maintaining possession of the ball. Working closely with team mates.</p> <p>Creating and using space.</p> <p>Regaining possession by:</p> <ul style="list-style-type: none"> <li>• denying space.</li> <li>• winning the ball.</li> </ul>	<p><b>1. 3 v 3 invasion game</b></p> <ul style="list-style-type: none"> <li>• Score by catching the ball over a specific line or within a specific area.</li> <li>• Given area.</li> <li>• No contact.</li> <li>• Keep score</li> </ul> <p><b>2. 3 v 3 with agreed rules.</b></p> <ul style="list-style-type: none"> <li>• no contact</li> <li>• no running with the ball</li> <li>• no kicking</li> <li>• start and restart with a throw-in from the sideline.</li> </ul>	<p><b>DECISIONS FOR TEAM IN POSSESSION</b> <b>How do we keep possession?</b> <b>How do we score?</b> Go and see!</p> <p><b>DECISIONS FOR TEAM WITHOUT THE BALL</b> <b>How do you get possession?</b> <b>How do you prevent opponents scoring?</b> Go and see!</p> <p><b>DECISIONS FOR TEAM IN POSSESSION</b> <b>Player with the ball.</b> <b>How do you keep possession?</b> Look up. Shield the ball. Pass to a team-mate who is free, i.e., in a space. Select appropriate pass - long, short, bounce, high, etc.</p> <p><b>Player without the ball.</b> <b>How can you help to keep possession?</b> By moving into a space. By signalling for a pass. By evading the opposition.</p> <p><b>DECISIONS FOR TEAM WITHOUT THE BALL</b> <b>How can you regain possession?</b> By closing down space. By marking a player or a space. By intercepting a pass.</p>

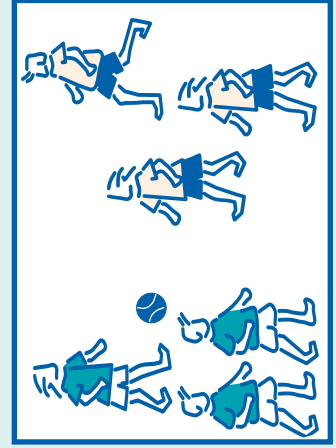

Unit 3: continued

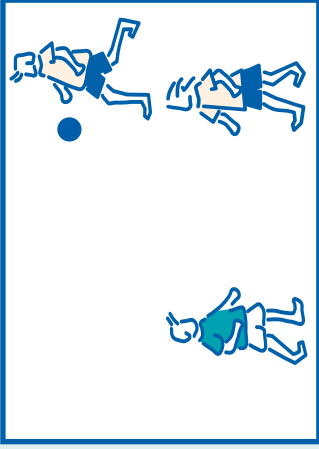
STAGE	CONCEPT	CONTENT / ACTIVITY	TEACHING POINTS
Development	<p>Awareness of others in game.</p> <p>Ability to support the player with the ball.</p> <p>Developing communication.</p>	<p><b>3. 2 v 1</b>  <b>The students work in groups of 3 and play a 2 v 1 game with specified boundaries (e.g. half of a badminton court).</b>                      The team of 2 in possession tries to execute as many passes as possible within one minute, keeping the ball from the challenger.                      Each interception reduces the score to zero.                      Challenger changes after one minute.</p> 	<p><b>DECISIONS FOR TEAM IN POSSESSION</b>  <b>Player with the ball.</b>  <b>How do you keep possession?</b>                      Which player is in the best position to receive a pass?                      A free player.  <b>What type of pass is most appropriate?</b>                      Go and see.  <b>When do you pass?</b>                      When your team mate is free and ready to receive a pass.</p> <p><b>Players without the ball.</b>  <b>How do you help to keep possession?</b>                      Get into a space and signal for a pass.  <b>How do you get into a space?</b>                      Move to a position where you can receive the ball by watching the opposition, changing direction, using speed.  <b>How do you signal for a pass?</b>                      By calling, using agreed hand signals, pointing to a space.</p> <p><b>DECISIONS FOR PLAYER IN OPPOSITION</b>  <b>How do you intercept the ball?</b>                      By anticipating the direction of the pass.                      By watching the movement of the ball.                      By putting pressure on the opposition.                      By making yourself as 'wide' as possible.</p>
Concluding activity	<p>Reinforcing concepts learned.</p> <p>Cool down.</p>	<p><b>4.</b> Return to 3 v 3 game as in activity 2.</p> <p>Walk - jog in 3's passing the ball.</p>	

## Unit 4: Invasion games

### LEARNING OUTCOMES

- The student will:**
- demonstrate an ability to make appropriate decisions regarding what to do and how to do it re: a) regaining and retaining possession and b) teamwork.

### EQUIPMENT

Ball(s), bibs, cones - ribbons / bibs, cones, basket, circle drawn.

### CLASS ORGANISATION

Basic: work in pairs / fours.

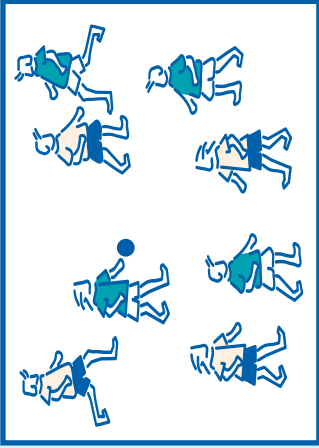
STAGE	CONCEPT	CONTENT / ACTIVITY	TEACHING POINTS
Warm up & stretching	Warm up.	Ball Balance Game (see resource materials).	
Introductory activity	<p>Appreciating the importance of imposing rules and conditions.</p> <p>Maintaining possession of the ball. Working closely with team mates.</p> <p>Creating and using space.</p> <p>Regaining possession by:</p> <ul style="list-style-type: none"> <li>Denying space.</li> <li>Winning the ball.</li> </ul>	<p><b>1. 4 v 4 with agreed rules.</b></p> <ul style="list-style-type: none"> <li>• no contact</li> <li>• no running with the ball</li> <li>• no kicking</li> <li>• start and restart with a throw-in from the sideline.</li> </ul> 	<p><b>DECISIONS FOR TEAM IN POSSESSION</b></p> <p><b>Player with the ball.</b>  <b>How do you keep possession?</b>                      Look up. Shield the ball.                      Pass to a team-mate who is free, i.e., in a space.                      Select appropriate pass - long, short, bounce, high, etc.</p> <p><b>Player without the ball.</b>  <b>How can you help to keep possession?</b>                      By moving into a space. By signalling for a pass.                      By evading the opposition.</p> <p><b>DECISIONS FOR TEAM WITHOUT THE BALL</b></p> <p><b>How can you regain possession?</b>                      By closing down space.                      By marking a player or a space.                      By intercepting a pass.</p>

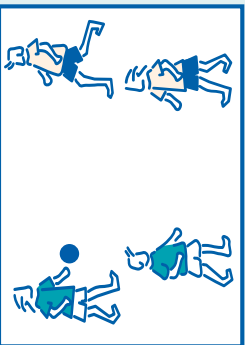
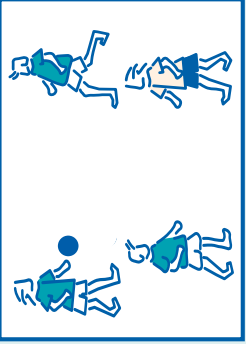

Unit 4: continued

STAGE	CONCEPT	CONTENT / ACTIVITY	TEACHING POINTS
Development	<p>Importance of team work.</p> <p>Creating and using space in possession.</p> <p>Retaining possession under increased pressure of time and opposition.</p> <p>Appreciation of the importance of communication.</p> <p>Ability to "read" the game when team is in possession and in opposition.</p> <p>Maximising possession.</p>	<p>2. <b>2 v 2.</b>                      Players in possession try to get as many passes as possible within a given time without the ball being intercepted.                      Possible variation:                      Players in possession have 5 "lives". They lose one life for each interception. They gain a life for five successive passes.</p>  <p>3. <b>3 v 1 Tag Game</b>                      Three students (with a ball) aim to touch a fourth player with the ball in order to get as many points as possible in one minute. When a player receives the ball he/she cannot run or throw the ball at the fourth player. The fourth player tries to avoid the ball by running, dodging, feinting, changing speed and direction.</p> 	<p><b>DECISIONS FOR TEAM IN POSSESSION</b>  <b>Player with the ball.</b>  <b>How do you get as many passes as possible?</b>                      By getting into a space and/or by getting close to your team mate.  <b>How can you evade opposition?</b>                      By moving quickly, by changing direction, by use of deception, by using all available space.  <b>When should you pass?</b>                      Ball should be passed only when team mate is likely to receive it.  <b>How will you pass?</b>                      Use different types of pass appropriate to situation.  <b>Player without the ball.</b>  <b>How do you help to keep possession?</b>                      Get into a space. Signal for a pass. Support the player with the ball.</p> <p><b>DECISIONS FOR TEAM WITHOUT THE BALL</b>  <b>How do you prevent passing in order to regain possession?</b>                      Deny space. Win the ball.</p> <p><b>DECISIONS FOR TEAM IN POSSESSION</b>  <b>What is the best way to get the opposition out?</b>                      By executing accurate passes.                      By communicating using teamwork.                      By positioning - denying space.  <b>Player with the ball.</b>  <b>To whom do you pass the ball?</b>                      Pass to player nearest the fourth player.  <b>What type of pass is appropriate?</b> Fast, accurate passes.  <b>Players without the ball.</b>  <b>How do you help to touch the fourth player?</b>                      Positioning near the player.                      Communicating with other team-mates. Face the ball.</p> <p><b>DECISIONS FOR PLAYER WITHOUT THE BALL (THE FOURTH PLAYER)</b>  <b>How do you avoid being touched?</b>                      By creating and using space. By using deception.                      By varying speed, change of direction.</p>
Concluding activity	<p>4. <b>Return to Activity 1.</b>  <b>4 v 4 with agreed rules.</b></p>		

Unit 5: Invasion games

**LEARNING OUTCOMES**

- The student will:**
- demonstrate an ability to make appropriate decisions regarding what to do and how to do it
    - a) being an effective team member and b) scoring.

**EQUIPMENT**

Balls, bats, cones

**CLASS ORGANISATION**

Groups of four.

**STAGE**

Introductory activity

**CONCEPT**

Denying space.  
 Ability to read the game and identify appropriate tactics.  
 Creating and using space by evasion and deception.

**CONTENT / ACTIVITY**

**4 v 4 Tag Game.**  
 The same rules as above (3 v 1) but four players attempt to get another team of four out by touching them with the ball.  
 Possible variation:  
 Touched players may be released by team mate going under their legs.

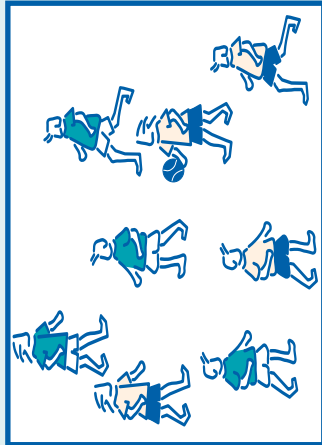

**TEACHING POINTS**

**DECISIONS FOR TEAM IN POSSESSION**

**How do you get the other team out?**

By working as a team in order to deny space.

**What tactics do the team use?**

**Is it better to concentrate on getting one player out at a time or to mark one opponent each?**

**How can you get your team to work well together?**

By communicating to each other, discussing ways of getting the other team out, identifying weaknesses.

**DECISIONS FOR TEAM WITHOUT THE BALL**

**How do you avoid being touched?**

- By using and creating space effectively.
- By use of evasive tactics and deception.
- By anticipating the moves of the opposition.
- If you are out you can still help your team by communicating.

**STAGE**

Development

Invasion of space - width, depth, support, penetration.  
Using appropriate attacking strategies.  
Working effectively as a team, e.g selecting a leader within the team.  
Identifying and using appropriate defence strategies.

**CONCEPT**

**CONTENT / ACTIVITY**

**4 v 4 Invasion Game**  
In order to introduce the concept of invading space to score a point a 4 v 4 invasion game with goals is introduced.  
Possible agreed rules:

- No contact, no running with ball, no kicking.
- Keep the ball on the ground, kicking, no handling.
- Start/restart with a throw-in from side line.
- Scoring system - ball is passed into a goal to score a point.

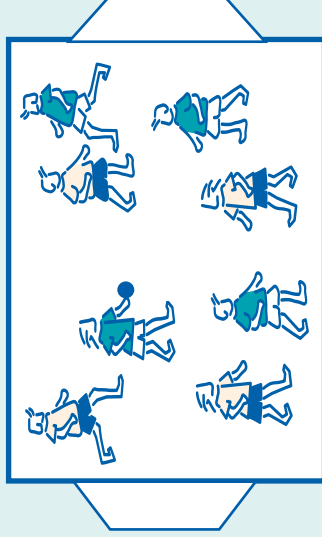

**TEACHING POINTS**

**DECISIONS FOR TEAM IN POSSESSION**  
**How can you score more effectively as a team?**  
By keeping possession.  
By moving forward using space, depth and width.  
By penetrating towards the goal to enhance scoring.  
By drawing out the opposition.  
By making the best use of your team mates.  
By discussing, selecting and using appropriate tactics.  
**What attacking strategies are appropriate?**  
Go and see.  
**Should you position 2 players forward, 2 back or 3 forward, 1 back or gamble all four?**

**DECISIONS FOR TEAM WITHOUT THE BALL**  
**How do you prevent scoring?**  
By regaining possession, defend space, intercept.  
**What defence tactics does your team use to prevent scoring?**  
**How do you defend your goal?**  
**Should you leave one player to defend the goal while the others try to regain possession?**

Concluding activity

Ability to read the game and show appropriate defensive strategy e.g. getting behind the ball, person to person or a combination of both.  
  
Cool down.

**4 v 4 Game**

- Emphasis on scoring.
- Large goals.

Call 'shot': Students may call 'shot' when in a good position to score. Defenders must stand aside and allow him / her to take a free shot at goal.

Variation:

The defenders 'freeze' when a player calls 'shot'. This puts more pressure on the attacker to call 'shot' at an appropriate time.

**DECISIONS FOR TEAM IN POSSESSION**

**How do you get into a good scoring position?**  
**Where is it easiest to score?**  
Near the goal.  
In the centre of the goal.

**DECISIONS FOR TEAM WITHOUT THE BALL**

**How do you prevent scoring?**  
Defend the goal by keeping attackers away from goal.  
Put pressure on attacker with the ball.  
Guard the front of the goal area (key scoring position).  
**How do you prevent goal hanging?**  
Introduce a no-go area.  
**Where do you position your players within this area?**  
e.g. Tall players in the middle, small players on the wings.  
**How do you defend your position within the area?**  
React to the ball and attacking player.  
By moving appropriately and use of defensive stance.

## Unit 6: Invasion games

### LEARNING OUTCOMES

- The student will:**
- demonstrate tactical problem solving in a variety of games situations.

### EQUIPMENT

Balls, bibs, task cards, cones, baskets / targets.

### CLASS ORGANISATION

Groups of four.

STAGE	CONCEPT	CONTENT / ACTIVITY	TEACHING POINTS
Warm up & stretching	Warm up.	Pairs, ball between two Move around room passing ball on call. <ul style="list-style-type: none"> <li>• Player with ball takes shot at nearest basket / target.</li> <li>• 5 passes.</li> <li>• Sit 5 passes.</li> </ul> Moving around room, passing continues between calls.	
Introductory activity Development	Ability to read the game and select appropriate defensive strategies e.g. Zone, Person to Person or a combination of both.  Understanding role of individual players in defensive play.	Double Goal (see resource materials). <ol style="list-style-type: none"> <li>1. The same game as Unit 5 but with a smaller goal area - e.g. a cone or basket.                             <div data-bbox="730 1251 1031 1618" data-label="Diagram"> </div> </li> <li>2. 4 v 4 To facilitate decision-making the teacher may set special tasks, e.g. if your team is one point ahead with 30 seconds to go what should you do?</li> <li>3. 4 v 4 Invasion Game                             <ul style="list-style-type: none"> <li>• No contact, no running with ball, no kicking,</li> <li>• Start/restart with a throw-in from side line.</li> <li>• Scoring system - basket or cone</li> </ul> </li> </ol>	<p><b>DECISIONS FOR TEAM WITH THE BALL</b>                      How do you get into a good scoring position?</p> <p><b>DECISIONS FOR TEAM WITHOUT THE BALL</b>                      How do you prevent scoring?                      By defending the goal.                      How can we prevent goal hanging?                      By introducing a defence zone.                      Where do you position certain players within the zone?                      e.g. tall players at the back, small players at the front.                      How do you defend your position within the zone?                      By moving appropriately and using defensive stance.</p> <p>See Task Cards.</p>
Concluding activities	Invasion of space - width, depth, support, penetration. Using appropriate attacking strategies. Working effectively as a team, e.g. selecting a leader within the team. Identifying and using appropriate defence strategies. Cool down.		<p><b>Final Game</b>                      Assessment                      Look for appropriate decisions in attack and defence.</p>

2

minutes left

1 point up

Your team has possession.

*What tactics do you use?*

2

minutes left

1 point down

Your team does not have possession.

*What tactics do you use?*

2

minutes left

1 point up

Your team does not have possession.

*What tactics do you use?*

2

minutes left

1 point down

Your team has possession.

*What tactics do you use?*

2

minutes left

1 point up

You have one player less.

Your team has possession.

*What tactics do you use?*

2

minutes left

Level score

You have one player less.

Your team has possession.

*What tactics do you use?*

**30**

seconds left

2 points down

Your team has possession.

2 pointers & 3 pointers available.

*What tactics do you use?*

**30**

seconds left

2 points up

Your team does not have possession.

2 pointers & 3 pointers available.

*What tactics do you use?*

*The opposition has a Task card.*

*From their tactics used try to find out what task they had to undertake.*

**CRAB BALL**

**5 v 5**

Players sit on the floor. Movement is by using hands and feet – no running, hopping, jumping.

Object is to pass ball into a target or to hit a cone and to defend own target.

**BALL BALANCE GAME**

A cooperative game where the students work in pairs with one ball.

Object of the game is to move from A to B keeping the ball balanced between body parts – no hands.

Ball may be placed between both sides, backs, legs, heads.

**DOUBLE GOAL GAME**

Two goals per team. Each team may attack and defend two goals.

Object is to score goals and to keep opposition guessing as to which goal the team is going to attack by quick changing of direction of play and deception.

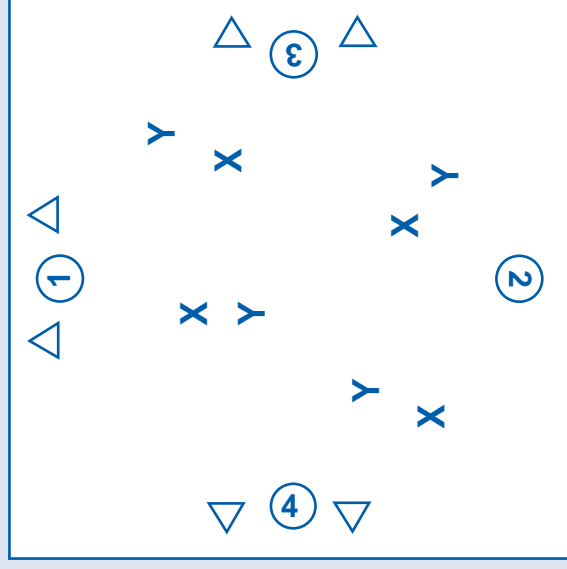

**KEEP YOUR TAIL**

Each student has a bib as a tail. On a given signal the student moves around the area attempting to collect as many tails as possible while trying to keep his / her tail.



NO. 1

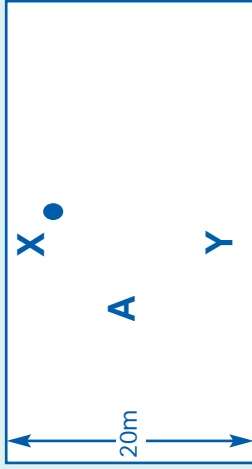

1. X with ball
2. X and Y jog to point A.
3. X passes ball to Y as they pass by and then jog on to the opposite side.
4. Both X and Y turn to return to A to repeat  
(Note: No sharp turns).
5. Constant light jogging with ball, change at A.
6. Vary ball change e.g.
  - a) simple pass
  - b) toss ball high
  - c) leave ball down
  - d) handpass.

NO. 2



Roughly 12 x 8 per two.

1. Ball between two – jog around area.
2. One leader, one follower. Leader has the ball.
3. On call
  - a) change leader
  - b) get a 1 – 2 pass
  - c) swap ball with someone else
  - d) swap partner.

NO. 3

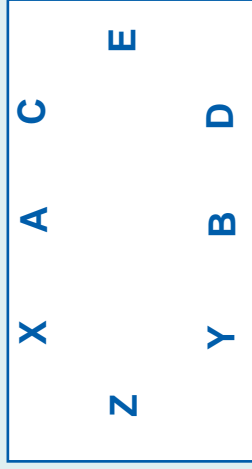

1. Ball each.
2. Students move around the area reacting to calls e.g.
  - a) dribble soccer style
  - b) bounce basketball style
  - c) sit down on ball and get up again
  - d) swap ball with someone else.

NO. 4

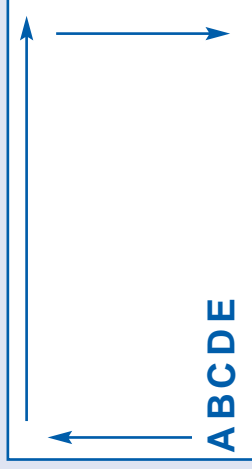

Line passing, rugby style, while moving around an area. A passes to B and so on. Can either pass back again, E to A, or if it is a big area, then A can loop around to get a pass from E.

NO. 5

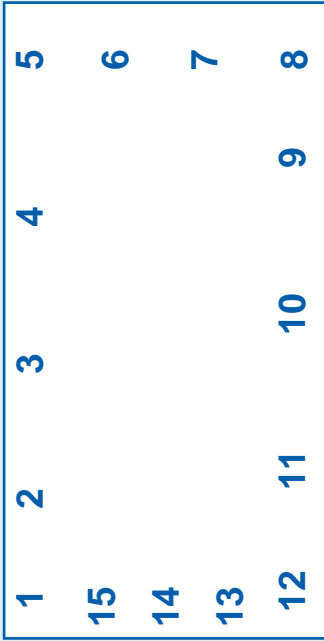

1. Movement circuit.
2. Students move from station to station.
3. All activities done at a low intensity – lasting 20 secs. per station  
e.g. of activities:
  - a) shuttle run – no sharp turns
  - b) jogging on the spot
  - c) pass ball off the wall
  - d) etc. etc.

NO. 6

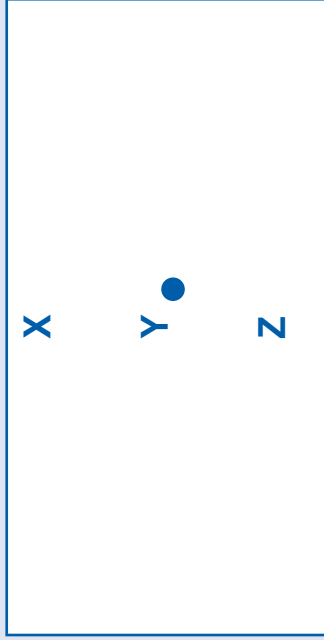

1. 3's – X, Y, Z. Y has the ball.
2. Y passes to X and goes to X's place.
3. X controls / catches and passes to Z and takes Z's place.
4. Z controls / catches and passes to X and so on.
5. After first three passes it should be virtually constant low intensity running with no sharp turns.

NO. 7

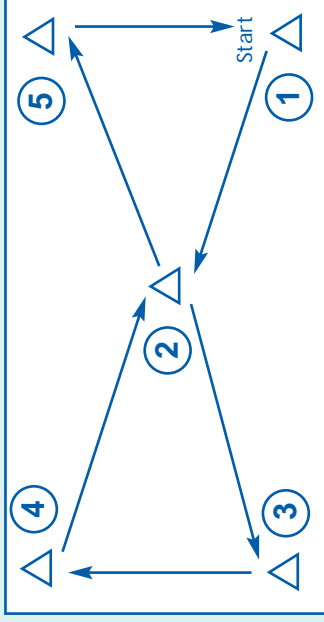

With / without ball – students jog from cone to cone performing a different action between each cone and maintaining a constant low intensity  
e.g. jog from 1 – 2  
hop from 2 – 3  
skip from 3 – 4  
side skip from 4 – 2  
grapevine from 2 – 5  
jog from 5 – 1

# Games



Badminton

Level  
Two

# Learning Outcomes

*The student will:*

- *gain insights into a variety of games through experiencing different types of games and through displaying a knowledge of basic principles and rules*
- *develop a technical competence commensurate with individual potential*
- *develop the ability to make appropriate responses (relative on their own abilities) to the particular problems posed by the game*
- *gain experience of various degrees of competitive play*
- *develop an understanding of the dynamics of team efficiency*
- *acquire a level of confidence and enjoyment which will encourage the playing of games outside of school time*
- *develop knowledge of how to modify games to make them work*
- *appreciate the benefits which participation in games can bring*
- *develop a sense of personal fulfilment through achieving a level of success in games playing.*



## Unit 1: Badminton

### LEARNING OUTCOMES

- The student will:**
- be introduced to the concept of height (giving time)
  - demonstrate an ability to make appropriate decisions regarding 'what to do' and 'how to do it'
  - co-operate with others
  - show an understanding of the service and boundary rules in badminton.

### EQUIPMENT

Nets, rackets, shuttles, long narrow courts, cones.

### CLASS ORGANISATION

2's, 3's and 4's.

## STAGE

### Warm up

Students in groups of 4.

X	X		X	X
1	2		3	4

Throw shuttle over net, run back to wall, touch, return in time to repeat. Group attempts to keep rally going.

### General stretching

Involve middle, upper and lower body.

### Development

Connecting with the shuttle.

An appreciation of the concept of time; learning that height gives an opponent time to get to shot and gives a player time to recover.

Moving appropriately to hit the shuttle.

Co-operating and communicating with other players.  
Concept of height.

### 1 (a) Co-operative Rally

- 1 v 1 over net.
- students hit the shuttle over and back using racket, trying to keep rally going.

**(b)** students continue as in (a) counting the number of consecutive shots hit

- they set a record - a class record or a personal record.

**(c)** Same as (a) but change partners.

### (d) 3 + 3 Co-operative Rally

- players arrange themselves as in diagram
- each player moves to end of line after one shot
- players try to keep rally going for as long as possible.

### Concluding activity

Appreciation of the concept of time whereby height will make rallying easier.

### Pyramids

3 v 3 Co-operative Rallying  
Team A and Team B play in half court. Each team has an agreed number of shuttles. Each pair tries to have rally of more than six shots. If this is achieved that shuttle is 'used up' and is transferred to other team. Team which uses up all its shuttles first, i.e., has no shuttles left, wins. If pair don't achieve six shots, team retains shuttle and next pair tries.

## TEACHING POINTS

- How can you help to keep rally going?
  - hit straight to your partner. Keep it high.
- Why does height help?
  - it gives time. - it's easier to hit it overhead.
- How can you prepare yourself for the next shot?
  - recover to ready position, i.e., racket up, position on court, etc.

### SKILL

### OVERHEAD CLEAR

- Does changing partner make any difference?
  - go and see.

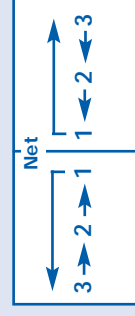

- How can you help to keep the rally going?
  - keep it high?

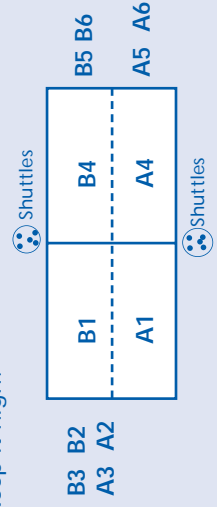

## Unit 2: Badminton

### LEARNING OUTCOMES

- The student will:
- understand the importance of the concept of time whereby height will make rallying easier
  - understand the rules of scoring / boundaries
  - demonstrate an ability to make appropriate decisions.

### EQUIPMENT

Nets, rackets, shuttles, long narrow courts, cones.

### CLASS ORGANISATION

2's, 3's and 4's

STAGE	CONCEPT	CONTENT / ACTIVITY	TEACHING POINTS
Warm up		Pyramids - see Unit 1.	
Stretching		Lower, middle, upper.	Reference to importance of flexibility in badminton.
Development	<p>The ability to move opponent around during the rally and on serve. Placing the shuttle to score points.</p> <p>Awareness of space on opponent's court and developing ability to put the shuttle there.</p> <p>Increasing the chance of scoring by attacking from the front of court.</p> <p>Reducing opponents time to react.</p>	<p><b>1 (a) 1 v 1 (long narrow court)</b></p> <ul style="list-style-type: none"> <li>competitive rally</li> <li>each player attempts to hit shuttle onto the ground on their opponents side. Point is won if the shuttle touches the ground or if your opponent fails to return the shuttle.</li> </ul> <p><b>(b) 1 v 1 7 / 9 point rally</b></p> <ul style="list-style-type: none"> <li>explain scoring system.</li> </ul> <p><b>(c) 1 v 1 Rotation of players</b></p> <ul style="list-style-type: none"> <li>each student plays with a new partner.</li> </ul>	<ul style="list-style-type: none"> <li>How do you score a point?                             <ul style="list-style-type: none"> <li>- get shuttle onto the ground.</li> </ul> </li> <li>Is there a need for boundaries?                             <ul style="list-style-type: none"> <li>- yes.</li> </ul> </li> </ul> <p>The question of service can be revised as appropriate.</p> <ul style="list-style-type: none"> <li>How is the game started, i.e., who serves?                             <ul style="list-style-type: none"> <li>- spin the racket/toss a coin/win the rally.</li> </ul> </li> <li>What do you need to get the shuttle onto the ground?                             <ul style="list-style-type: none"> <li>- space.</li> </ul> </li> <li>Where are the spaces?                             <ul style="list-style-type: none"> <li>- front and back.</li> </ul> </li> <li>Where is it easiest to serve from?                             <ul style="list-style-type: none"> <li>- front</li> </ul> </li> <li>Where do you want your opponent to be?                             <ul style="list-style-type: none"> <li>- back.</li> </ul> </li> <li>How can you give your opponent less time?                             <ul style="list-style-type: none"> <li>- keep the shuttle low.</li> <li>- play the shuttle fast.</li> </ul> </li> </ul> <p><b>SKILL</b></p> <ul style="list-style-type: none"> <li>OVERHEAD DROP CLEAR</li> <li>UNDERHAND DROP SHOT</li> <li>SMASH</li> </ul>

Unit 3: Badminton

**LEARNING OUTCOMES**

- The student will:**
- be able to deny opponent space in own court area
  - demonstrate an ability to make appropriate decisions
  - demonstrate the overhead, drop and smash shots.

**EQUIPMENT**

Nets, rackets, shuttles, long narrow courts, cones.

**CLASS ORGANISATION**

2's, 3's and 4's.

**STAGE**

**Warm up**  
5 mins.

Students should be made aware of different emphasis on points depending on own score / opponent score

**Warm up**  
5 mins.

**Development**

Defend space on own court.  
Create time to recover.  
Use of deception to disguise your intention.  
Limit opponent's time by playing drop shot / smash.

**CONCEPT**

**King / Queen of the Castle**  
In groups of 4 / 6, students take it in turns to play a competitive rally. The winner of the point remains on the court, moving to the 'King/Queen's side', and the loser leaves the court. Waiting players come on in turn to challenge. The first person to get 5 points is 'King/Queen of the Castle'.  
Players get a score only for a point won on the King/Queen's side of the court. As players come on to the challenging side they bring a shuttle on and always start the rally. If beaten when on the King's side they rejoin the line but hold onto points already won.

Stretching

**CONTENT / ACTIVITY**

**(a)** 1 v 1 7 / 9 Point Rally  
• same as Unit 2

**(b)** 1 v 1  
• denying opponent space

**(c)** **Reaction call practice**  
to cover court. Teacher (or student) calls position he wants students to go to.  
e.g. front, back, right, left, front smash, front drop, etc.  
• students stand in middle of court in ready position, on signal move and return immediately to centre.

**(d)** 1 v 1 practicing the above (c).

**(e)** 1 v 1 Game same as (a)

**(f)** Change partners

**TEACHING POINTS**

- When do you want your opponent to be at the back?
- How do you get your opponent to the back?
- What else can you do?  
- spot **weaknesses**, e.g. backhand etc.

- To deny your opponent space where should you stand on the court?  
- the middle.
- Is this always best?
- When your opponent is at the back of the court what should you do?  
- anticipate short return.  
- you bring your opponent to the front of the court with a drop shot.
- Where should you defend?  
- front
- Where are the spaces?
- What is the best way to move about the court to different partners?  
- stretch, head up.
- Don't run, why not?  
- go and see.

Unit 4: Badminton

**LEARNING OUTCOMES**

- The student will:**
- show an understanding of creating space laterally, i.e., right and left
  - demonstrate an ability to make appropriate decisions
  - show an ability to do the underhand drop and smash.

**EQUIPMENT**

Nets, rackets, shuttles, long narrow courts, cones.

**CLASS ORGANISATION**

2's, 3's and 4's.

STAGE	CONCEPT	CONTENT / ACTIVITY	TEACHING POINTS
Warm up		Reaction calls (like Unit 3) <b>(a)</b> Use of numbers, e.g. (1) net, (2) right, (3) back, (4) left. <b>(b)</b> Change numbers, e.g. (1) left, (2) back, (3) net, (4) right.	<ul style="list-style-type: none"> <li>• What's the best way to do this?</li> <li>- Stretching, head up, back straight, racket ready.</li> </ul>
Development	Keeping shuttle low to give opponent less time.  Use of space! Place the shuttle left and right as spaces become exposed. Use of deception.	<b>(a) 1 v 1 (short, wide court)</b>  <b>(b) 1 v 1</b> throw shuttle to find spaces (without racket). <b>SKILL</b> DROP SHOT • SMASH  <b>(c) 1 v 1 with racket</b> 7 / 9 point rally  <b>(d) Rotate partners</b>	<ul style="list-style-type: none"> <li>• Where are the spaces? - sides.</li> <li>• How can you make it harder for your opponent? - keep shuttle close to net.</li> <li>• How can you defend space? - position yourself. Racket ready position.</li> </ul> <ul style="list-style-type: none"> <li>• Where is the best place to defend?</li> <li>* Where is the best place to attack?</li> </ul>



## Unit 5: Badminton

### LEARNING OUTCOMES

- The student will:**
- show an understanding of the concepts and problems inherent in badminton
  - demonstrate an ability to make appropriate decisions
  - understand the rules of badminton.

### EQUIPMENT

Nets, rackets, shuttles, long narrow courts, cones.

### CLASS ORGANISATION

2's, 3's and 4's.

## STAGE

### Warm up

This game highlights consistency and puts pressure on players to win several points in a row.

## CONCEPT

**"Belts"**  
In teams of 3 - 5, players aim to beat opponent and win "belts" for their team. A player must beat 3 opponents consecutively to win a "belt". The first team to win 3 / 5 belts are the winners. Two players, one from each team, play each other. As players win they remain on court. Player coming on always has a shuttle and starts play. If a player wins a belt he / she must leave the court and join the back of his / her teams line. Players coming on always start with 0 points.

## CONTENT / ACTIVITY

### Stretching

Lower, middle, upper body.

### Development

Creating, attacking and defending space. Awareness of time and its effect on play - Rules of full court. Boundaries for full court

### (a) 1 v 1 (full court) 5 point rally

- teams of 3 / 4 per court
- players not playing: refereeing, advising, spotting weaknesses of team mate and opponents.

Effects of time, e.g. speeding up attack, slowing down the game to give time to recover etc.

### (b) 1 v 1 rotate players

### (c) 1 v 1

- area of gym reserved to practice and work on weaknesses, e.g. backhand, drop shots, etc.

## TEACHING POINTS

As before.

- How do you beat an opponent?
- look for weaknesses, e.g. backhand, runs, etc.

- Can you send your opponent to the back of the court with your serve / return of serve?
- What does this do?

- it creates space.

- it puts my opponent in a weak position.

- Can you place the shuttle into the space with precision / speed / deception?
- Can you identify areas of strengths / weaknesses in your opponent's game?

- Can you exploit these weaknesses?

- Can you reduce options available to your opponent by good defence positions on the court?  
e.g. covering front court to force a high defensive shot.

## Unit 6: Badminton

### UNIT OBJECTIVES

- The student will:**
- co-operate with others;
  - demonstrate an ability to make appropriate decisions
  - show an understanding of the rules of the game

### EQUIPMENT

Nets, rackets, shuttles, long narrow courts, cones.

### CLASS ORGANISATION

2's, 3's and 4's.

STAGE	CONCEPT	CONTENT / ACTIVITY	TEACHING POINTS
Warm up		<p><b>(a) 2 v 2 shared racket</b></p> <ul style="list-style-type: none"> <li>• two players with one racket between them play opposite another two players, who also share a racket</li> <li>• players continue to rally over and back but must give the racket to their partner after each hit</li> <li>• co-operation, i.e., try to keep rally going</li> </ul> <p><b>(b) Competition</b> - keep score</p>	<ul style="list-style-type: none"> <li>• How can I keep rally going?</li> <li>• How can I help my partner?</li> <li>- keep shuttle high.</li> </ul>
Stretching		Lower, middle, upper body	
Development	<p>Creating, attacking and defending space. Teamwork. Rules and boundaries for doubles.</p>	<p><b>(a) 2 v 2 doubles</b></p> <p><b>(b) Rotate 2 v 2</b></p> <ul style="list-style-type: none"> <li>• play against different pair.</li> </ul> <p><b>(c) Change partner</b></p>	<ul style="list-style-type: none"> <li>• Where are the spaces?</li> <li>- depends.</li> <li>• How can you increase your chances of putting the shuttle into the space?</li> <li>- playing from the front.</li> <li>• In doubles, what is the best formation? Side by side, one front, one back?</li> <li>- go and see.</li> <li>• Can you identify weaknesses in your opponents? Backhand, or not calling for 50/50 shuttle?</li> <li>• Does this make a difference?</li> </ul>

# Games



Gaelic football

Soccer

Level  
Two



## GAELIC FOOTBALL

Unit 1: Gaelic football

**LEARNING OUTCOMES**

- The student will:**
- demonstrate a knowledge of the basic principles and concepts of invasion games
  - demonstrate an ability to use the hand pass
  - co-operate with others in group decision making
  - contribute to group effort.

**EQUIPMENT**

15 balls (ball between 2 or 3), bibs, cones, goals.

**CLASS ORGANISATION**

5 v 5, 2's or 3's for hand pass

STAGE	CONCEPT	CONTENT / ACTIVITY	TEACHING POINTS
Warm up		Choose activity from examples in Level 1. Stretching.	
Development	<p><b>Recap</b></p> <ul style="list-style-type: none"> <li>• Keep possession</li> <li>• Create space</li> <li>• Regain possession</li> </ul> <p><b>Invading space:</b></p> <ul style="list-style-type: none"> <li>- width</li> <li>- depth</li> <li>- support</li> <li>- penetration</li> </ul> <p><b>Denying space:</b></p> <ul style="list-style-type: none"> <li>- interception</li> <li>- marking</li> <li>- space</li> <li>- player</li> </ul>	<p>1. <b>5 v 5 Possession Game:</b> time limit or number of passes. throw and catch – cannot travel with ball.</p> <p>2. As above, using hand pass.</p> <p style="background-color: #008080; color: white; padding: 2px; text-align: center;"><b>SKILL</b></p> <p style="background-color: #008080; color: white; padding: 2px;">- Gaelic hand pass</p> <p>3. <b>Line ball: 5 v 5. Area 30 x 40 meters:</b></p> <ul style="list-style-type: none"> <li>- cannot move with ball</li> <li>- no tackling</li> <li>- score by hand pass across line to team mate</li> <li>- no kicking</li> </ul>	<ul style="list-style-type: none"> <li>• How do you keep possession?</li> <li>• How do you help keep possession?                             <ul style="list-style-type: none"> <li>- Player with ball</li> <li>- Player without ball.</li> </ul> </li> <li>• How can you score more effectively as a team?</li> <li>• How do you prevent scoring?</li> </ul>
Concluding activity	<ul style="list-style-type: none"> <li>• <b>Teamwork</b></li> <li>• As above</li> </ul>	<p><b>5 v 5 with goal:</b></p> <ul style="list-style-type: none"> <li>- points only</li> <li>- hand pass only</li> <li>- cannot move with ball</li> <li>- no tackling</li> </ul>	<p>As above</p> <ul style="list-style-type: none"> <li>• What is the difference between defence / attack of a line or goal?</li> </ul>
Cool down & stretching		Gentle jog – handpass ball between 2's or 3's	

Unit 2: Gaelic football

**LESSON OBJECTIVES**

- The student will:**
- demonstrate an ability to make appropriate decisions relating to 'what to do' and 'how to do it' in a 5 v 5 invasion game
  - demonstrate an ability to travel with the ball using toe to hand and/or bounce.

**EQUIPMENT**

15 balls (ball between 2 or 3), bibs, cones, goals.

**CLASS ORGANISATION**

5 v 5, 2's or 3's for pick-up

STAGE	CONCEPT	CONTENT / ACTIVITY	TEACHING POINTS
Warm up		Ball between two. Hand passing while jogging slowly around field.	
Introductory activity		5 v 5 tag – (as in level 1), using hand pass.	
Development	As in unit 1. <ul style="list-style-type: none"> <li>• Ability to read game and select appropriate actions</li> <li>• Moving effectively with ball</li> </ul>	<p><b>1. 5 v 5 game</b></p> <ul style="list-style-type: none"> <li>– points only</li> <li>– no tackling</li> <li>– hand pass only</li> </ul> <p><b>2. 5 v 5.</b></p> <p>As above + travelling with ball</p> <ul style="list-style-type: none"> <li>– 1 solo + 1 bounce + limited steps</li> </ul> <p><b>SKILL</b> Toe to hand. (Toe tap)</p>	<ul style="list-style-type: none"> <li>• Continue to question students on decisions which need to be made regarding attack and defence.</li> <li>• <b>When is it appropriate to:</b> <ul style="list-style-type: none"> <li>– pass?</li> <li>– travel with ball?</li> </ul> </li> <li>• See resource material.</li> </ul>
Concluding activity		<b>5 v 5 Game as in Activity 2.</b>	
Cool down & stretching		Gentle jog – 1 solo or 1 bounce then hand pass in 2's or 3's	

## Unit 3: Gaelic football

### LEARNING OUTCOMES

- The student will demonstrate an ability to:
  - make appropriate decisions in a game situation
  - pick the ball off the ground correctly
  - foot pass the ball
  - contribute to group effort
  - assume responsibility by adhering to agreed rules.

### EQUIPMENT

15 balls (ball between 2 or 3), bibs, cones, goals – e.g. flags (1.5m)

### CLASS ORGANISATION

5 v 5, 2's or 3's for kick pass

STAGE	CONCEPT	CONTENT / ACTIVITY	TEACHING POINTS
Warm up		In two's hand pass and toe to hand jogging around.	
Introductory activity		<p><b>1. 5 v 5</b> As in unit 2</p> <ul style="list-style-type: none"> <li>– with bigger area</li> <li>– with foot pass from hand</li> <li>– score using hand.</li> </ul>	<ul style="list-style-type: none"> <li>• What are the implications of the bigger area and the foot pass?</li> <li>• How do you get the ball into your hands?</li> <li>• Who do you pass the ball to?</li> <li>• How can you make yourself free for a pass?</li> </ul>
Development	<p><b>Support</b></p> <ul style="list-style-type: none"> <li>- Width</li> <li>- Depth</li> <li>- Communication</li> <li>- Penetration</li> </ul>	<p><b>2. SKILL</b></p> <ol style="list-style-type: none"> <li>1. Pick up.</li> <li>2. Kick pass.</li> <li>3. Getting away from an opponent for a pass.</li> </ol> <p>Where necessary, groups may be broken down to facilitate skill work on some or all of these.</p>	<ul style="list-style-type: none"> <li>• When do you use a kick pass/hand pass?</li> <li>• How do you kick pass?</li> </ul> <p><b>SKILL</b> KICK PASS</p> <ol style="list-style-type: none"> <li>1. Eyes on ball when kicking.</li> <li>2. Keep toe pointing to ground.</li> <li>3. Knee bent over ball and raised upwards as you kick.</li> </ol> <ul style="list-style-type: none"> <li>• Risk of longer pass re accuracy and pace.</li> </ul>
Concluding activity	<p><b>Support</b></p> <ul style="list-style-type: none"> <li>– Distance between team mates</li> </ul>	<p><b>3. 2 v 2 or 3 v 3 Possession</b> Foot pass only.</p> <p><b>4. 5 v 5</b> With emphasis on above – now that students have highlighted the implications of the bigger area and the use of the foot pass.</p>	
Cool down & stretching		Gentle jog – practising foot pass, pick-up, etc.	

## Unit 4: Gaelic football

### LESSON OBJECTIVES

- The student will:**
- show an understanding of attack / defence roles in gaelic football
  - co-operate with others in group decision making
  - contribute to group effort.

### EQUIPMENT

15 balls (ball between 2 or 3), bibs, cones, goals.

### CLASS ORGANISATION

Move to bigger group numbers: 6 v 6, 7 v 7, 8 v 8

STAGE	CONCEPT	CONTENT / ACTIVITY	TEACHING POINTS
Warm up		In two's handpass and toe to hand while jogging around. Stretching. Fist dodgeball game.	
Introductory activity	<b>Keep possession</b>	<b>5 v 5 in grid of 30 x 40 yards</b> - keep possession - kick pass only - can travel with the ball - limited number of steps + bounces + foot to toe	
Development	<b>Teamwork</b> - Specific roles e.g. defending, attacking, goal, midfield	<b>1. 6 v 6, 7 v 7 or 8 v 8</b> depending on class size (60 x 40 yards) Still one solo / one hop <b>SKILL PUNT PASS</b> See resource materials.	<ul style="list-style-type: none"> <li>• How do you organise yourselves to work effectively as a team? - allocating positions - team line out</li> <li>• How do you change the players for each position?</li> <li>• What are the defence/attack implications? - do you mark player/area - do you follow player back towards her/his goal?</li> </ul>
Concluding activity		<b>2.</b> Students can then be allocated specific roles (e.g. defender) within a specific area. Rotate students regularly so that all get an opportunity to play different roles. Score by hand pass point or kick pass point or goal.	<ul style="list-style-type: none"> <li>• <b>On a larger pitch</b> How do you pass the ball to your team mate when there is an opponent(s) between you?</li> </ul>
Cool down & stretching			



## Unit 5: Gaelic football

### LEARNING OUTCOMES

- The student will:**
- show an understanding of creating space for shooting
  - demonstrate an ability to score from the hands.

### EQUIPMENT

15 balls (ball between 2 or 3), bibs, cones, goals.

### CLASS ORGANISATION

Group of 3's, 6's or larger.

STAGE	CONCEPT	CONTENT / ACTIVITY	TEACHING POINTS
<p>Warm up</p> <p>Introductory activity</p>	<p><b>Movement in attack</b> Penetration</p> <p><b>Defending</b> - slowing down the opposition</p>	<p>Ball between three - jogging around - on signal do activity such as pass/solo/pick up etc.</p> <div style="text-align: center;"> </div> <p><b>Objective</b> For X's to carry ball over goal line O1 passes to one of the X's and then tries to get back to help O2 and O3 to defend.</p>	<ul style="list-style-type: none"> <li>• Most effective attacking strategy?                     <ul style="list-style-type: none"> <li>- move / pass quickly before O1 gets back</li> </ul> </li> <li>• Best way to defend?                     <ul style="list-style-type: none"> <li>- try to hold up attackers until O1 gets back</li> </ul> </li> <li>• What are the defence/attack implications?                     <ul style="list-style-type: none"> <li>- do you mark player/area</li> <li>- do you follow player back towards her/his goal?</li> </ul> </li> </ul>
<p>Development</p>	<p>Creating space for shot</p> <p><b>Support</b> Width / Depth Penetration Creating Space</p>	<p><b>1. 6 v 6, 7 v 7 or 8 v 8 in area (60 x 40 meters)</b> Call shot game - all action freezes once a player has possession and calls shot.</p> <p><b>SKILL</b> - shooting</p> <p><b>2.</b></p>	<ul style="list-style-type: none"> <li>• When is it best to call shot?                     <ul style="list-style-type: none"> <li>- close to goal</li> <li>- good angle</li> </ul> </li> <li>• How do you get free to get a shot?</li> <li>• When is it best to shoot/pass?</li> <li>• When is it best to go for a point/go for a goal?</li> </ul>
<p>Concluding activity</p> <p>Cool down &amp; stretching</p>		<p><b>3. 6 v 6, 7 v 7, 8 v 8</b> - score goals / points - one bounce / toe tap.</p>	

Unit 6: Gaelic football

**LEARNING OUTCOMES**

- The student will:**
- demonstrate an understanding of the attacking and defending principles involved in gaelic football
  - demonstrate an ability to make appropriate decisions regarding 'what to do' and 'how to do it' in a game of gaelic football.

**EQUIPMENT**

15 balls (ball between 2 or 3), bibs, cones, goals.

**CLASS ORGANISATION**

Groups of 4 or larger.

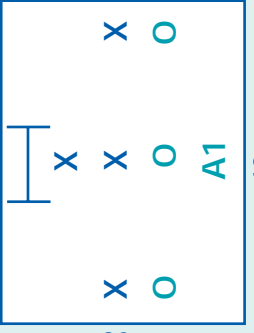
STAGE	CONCEPT	CONTENT / ACTIVITY	TEACHING POINTS
Warm up		Give appropriate warm up.	
Introductory activity	Movement/Penetration	<p>1. As introductory activity for lesson 5 .</p>	
Development	<p><b>Defending</b></p> <ul style="list-style-type: none"> <li>- slowing down</li> <li>- interception</li> </ul> <p><b>Attack</b></p> <ul style="list-style-type: none"> <li>- drawing out opposition</li> <li>- teamwork</li> <li>- creating space</li> <li>- shooting / scoring</li> </ul> <p><b>Defence</b></p> <ul style="list-style-type: none"> <li>- denying shooting space</li> <li>- closing down player with the ball</li> <li>- marking</li> </ul>	<p>2. <b>4 v 4</b></p> <p>A1 starts play with ball. O's attack goal defended by X. After 5 attempts the O's and X's swap positions.</p> <p>A1 not allowed to score.</p>  <p>30m</p> <p>40m</p> <p>3. <b>Possible variation:</b> A1 joins with attack.</p>	<ul style="list-style-type: none"> <li>• Best way to score: point/goal?</li> <li>• How do we create space in attack?</li> </ul>
Concluding activity		<p>4. <b>6 v 6, 7 v 7, 8 v 8 final game</b></p> <ul style="list-style-type: none"> <li>- still only one bounce / toe to hand</li> </ul>	
Cool down & stretching			

## HAND PASS

### SKILL DRILLS

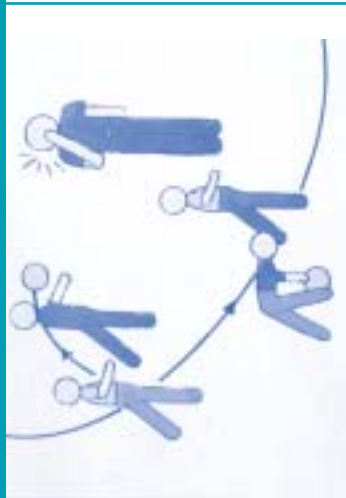

### JOG & PICK UP AND HAND PASS

Organise pairs into circle or square formations. On the whistle the ball is placed on the ground and pairs jog towards next ball for one to pick up. Pairs then keep fist passing to each other until the whistle sounds for the ball to be replaced on the ground and the drill to be repeated.

### SKILL DEMONSTRATION



### HAND PASS

1. Always face team mate when receiving pass.
2. Strike ball with palm of hand.
3. Hold platform hand steady and in position as the ball is struck with the other hand.

### FIST PASS

Same as hand pass except the ball is fisted away instead of palmed.

### SKILL DRILLS

#### (a) HAND PASS TO PARTNER

Collect ball and stand 3m from partner. Hand pass ball to partner who catches in fingers in front of body and repeats.

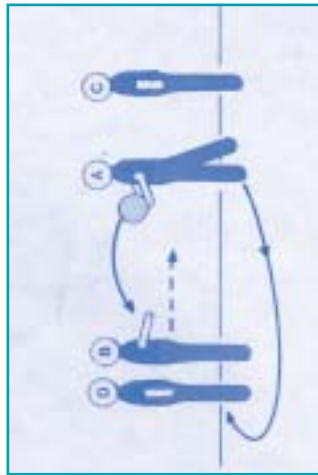

#### (b) HAND PASS WHILE MOVING

4 groups of pairs 10m apart. A moves towards opposite file, hand passes ball to B, moves to rear and awaits next turn. B repeats with C. Team is finished when A returns to front position in original file. Encourage the use of the left and right hand when performing fist passes.



### FIRST DODGE BALL

4 groups of pairs within a circle. One player chosen as "it" fists the ball at feet of other players who try to dodge but who must remain within circle.

### TOUCH BALL

As the ball is fisted between players in circle formation, one player - "it" - tries to touch the ball. If successful, last player to play the ball becomes "it".

TOE-TAP



1. Hand holding ball is lowered towards kicking leg, releasing the ball.
2. Eyes on ball.
3. Straighten your leg as you flick your instep upwards.
4. Try toe-tap with non-preferred foot.

SKILL DRILLS

**KEEP BALL UP**

Using foot only, each player in turn counts how many foot taps he/she can perform before the ball hits the ground.

Encourage those who are competent to try keeping the ball up, using their weak leg.

**TRY AND BEAT YOUR PARTNERS HIGHEST COUNT.**

**TOE-TAP TAG**



Use a confined area (basketball court) 5-6 per team.

Team A, each toe-tapping a ball as they run, chase and try to tag players of other team by touching them with the ball.

Each team tries to tag as many players as they can in one minute. Rotate teams so all get a chance of chasing. Emphasise safety aspect.

**TOE-TAP ROUND PARTNER**

Stand 10m apart. Toe-tap the ball as you move towards and around your partner and back. Then kick to partner to repeat.

**KICK PASS – CROUCH LIFT**

**SKILL DRILLS**

**KICK PASS TO PARTNER**

Stand 10m apart. Kick the ball to your partner's chest. Partner attempts different catches and repeats.

Alternate legs. Bring the students together if they experience difficulty with the weaker leg.

**10-UP KICK PASS**

Stand with partner 5 m apart and kick for partner to catch. Set a target of 10 successful catches for each pair.

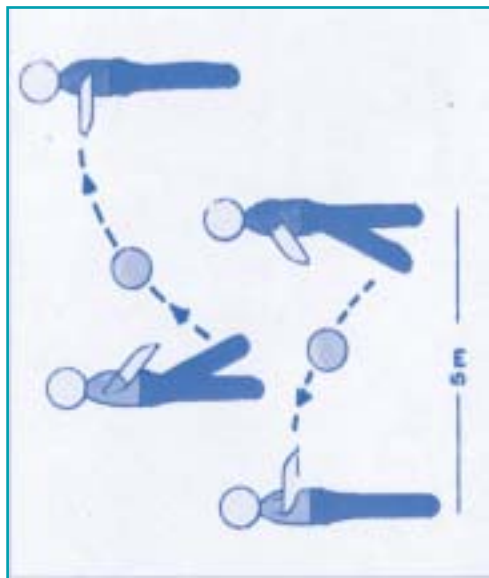

**CROUCH LIFT**

In a circle formation, while moving around, each player in turn crouch-lifts the ball and replaces carefully for the next player to repeat. Alternate moving in a clockwise and anti-clockwise direction.

Use leg to lift the ball into cupped hands in front of ball. Try jogging.



**CROUCH-LIFTING MOVING AWAY**

A runs out and rolls ball along ground in front and then crouch-lifts it and fist passes to B. A then awaits turn behind D, B repeats, etc.

Encourage players to crouch-lift and fist pass with the weaker leg and hand.



**CROUCH-LIFT ROLLING BALL**  
Pairs stand 1m apart in a circle or square formation. While jogging around, one player gently rolls the ball in front of partner for him/her to crouch lift.

Place supporting leg well in front and to side of the ball. Lift ball with other leg into cupped hands.

PUNT PASS

SKILL DEMONSTRATION



**PUNT KICK**

Used mainly when facing or moving directly towards target.

Main points of skill to be mentioned:

1. Eyes on ball.
2. Kick with the instep (laced part) of boot.
3. Follow through in direction of target.

## TEAM IN POSSESSION

## PLAYER WITH THE BALL

- **How do you keep possession?**  
Look up.  
Shield the ball.  
Pass to a team mate who is free.  
Select appropriate pass.
- **Which player is in the best position to receive a pass?**  
A free player.
- **What type of pass is most appropriate?**  
Depends on situation.
- **When do you pass?**  
When your team mate is free and ready to receive a pass.
- **How can you evade opposition?**  
By moving quickly, by changing direction, by use of deception, by using all available space.
- **How will you pass?**  
Use different types of pass appropriate to situation.
- **What should I think about when I get the ball?**
  - Can I score?
  - Can I get into a better position to score?
  - Can I pass to team-mate in a better position?

## PLAYER WITHOUT THE BALL

- **How can you help to keep possession?**  
By moving into a space.  
By signalling for a pass.  
By evading the opposition.
  - **How do you get into space?**  
Move to a position where you can receive the ball by watching the opposition, changing direction, using speed etc.
  - **How do you signal for a pass?**  
By calling, using agreed hand signals, pointing to a space etc.
- OTHER QUESTIONS**
- **How can you score more effectively as a team?**  
Keeping possession.  
By moving forward towards the goal to enhance scoring.  
By drawing out opposition.  
By making the best use of team mates.  
By discussing, selecting, using appropriate tactics.
  - **What attacking strategies are appropriate?**  
Depends.

## DECISIONS FOR TEAM WITHOUT THE BALL

- **How can you regain possession?**  
By closing down space.  
By marking a player or space.  
By intercepting a pass.
- **How do you intercept the ball?**  
By anticipating the direction of the ball.  
By putting pressure on the opposition.  
By making yourself as wide as possible.
- **How do you prevent passing in order to regain possession?**  
Deny space.  
Win the ball.
- **How do you prevent scoring?**  
By regaining possession, defend space, intercept.
- **What defence tactics does your team use to prevent scoring?**
- **What is the best way to defend?**  
Try to close down ball carrier.  
Stay on balls of feet.  
Side on, don't ball watch.
- **How do you position your players?**  
e.g. tall players in the middle.  
smaller players on the wings.
- **How do you defend your position within area?**  
React to ball and attacking player.  
By moving appropriately and use of defensive stance.





## Unit 2: Soccer (Passing)

### LEARNING OUTCOMES

- The student will:**
- demonstrate an ability to make appropriate decisions about when to pass and when to shoot
  - demonstrate accuracy in passing / shooting.

### EQUIPMENT

Ball between two, cones, goals, bibs.

### CLASS ORGANISATION

STAGE	CONCEPT	CONTENT / ACTIVITY	TEACHING POINTS
Warm up		<p>In three's pass ball through cones. Ball starts at Y. Y passes and follows to X, etc.</p> <p style="text-align: center;">                     X   ●   Y   ●   Z                      ●   ●   ●   ●   ●                 </p>	<p>Slow, gentle movement. Get pass through the cones.</p>
Development	<p>Getting into positions to score</p> <p>When to shoot / when to pass</p> <p>Support</p>	<ol style="list-style-type: none"> <li><b>1. Line Ball Game</b> Pass through 2 / 3 goals to score. 30 / 40</li> <li><b>2. Call Shot Game</b> <ul style="list-style-type: none"> <li>• everyone gets out of way</li> <li>• freeze.</li> </ul> </li> </ol>	<ul style="list-style-type: none"> <li>• Focussed goals - what differences from having to run over line?</li> <li>• More goals scored?</li> <li>• Easier / harder to defend?</li> <li>• When is it best to call shot?                             <ul style="list-style-type: none"> <li>- near goal</li> <li>- in good control</li> <li>- when space is available.</li> </ul> </li> <li>• A shot is just like a strong pass</li> <li>• Central focus</li> <li>• Where do you want to make space?                             <ul style="list-style-type: none"> <li>- near goal, central position.</li> </ul> </li> <li>• What's needed when you get into space                             <ul style="list-style-type: none"> <li>- quick, accurate pass from team mate.</li> </ul> </li> </ul>
Conclusion		<ol style="list-style-type: none"> <li><b>3. One Goal - bigger area</b> <ul style="list-style-type: none"> <li>• option of call shot</li> <li>• option of a goalkeeper.</li> </ul> </li> <li><b>4. 5 - 4 - 3 - 2 - 1 variation</b> Each team member has 'two touches'. Each goal gives the team an extra touch to a maximum of 5 and each miss loses a touch to a minimum of 1.</li> </ol>	
Cool down		<ol style="list-style-type: none"> <li><b>5.</b> Same as warm up with greater emphasis on accuracy.</li> </ol>	

Unit 3: Soccer (Creating space)  
**The student will:**

- show an ability to create space to receive possession
- demonstrate one turn with the ball
- contribute to group effort.

**LEARNING OUTCOMES**

**EQUIPMENT**  
 Ball between two, cones, goals, bibs.  
**CLASS ORGANISATION**

STAGE	CONCEPT	CONTENT / ACTIVITY	TEACHING POINTS
Warm up	Control	Ball between two. Follow the leader. Alternate leader.	Try to 'shake off' partner.
Development	<ul style="list-style-type: none"> <li>Creating space as an individual</li> <li>Speed of thought</li> <li>Speed of movement</li> <li>Knowing when to move</li> </ul>	<ol style="list-style-type: none"> <li><b>30 x 40 meters. Two goals. 5 v 5 / 6 v 6</b> <ul style="list-style-type: none"> <li>optional goalkeeper</li> <li>play person to person with one player in each team free</li> </ul> </li> <li><b>Ways of creating space</b> <ul style="list-style-type: none"> <li>turns - inside / outside</li> <li>speed</li> <li>feints</li> </ul> </li> <li><b>2 v 1 Game 10 x 20 meters area</b> <ul style="list-style-type: none"> <li>1 start by marking one of 2</li> <li>2 attack goal. Alternate positions</li> <li>require 2 to make a certain number of pass prior to scoring.</li> </ul> </li> </ol>	<ul style="list-style-type: none"> <li>How do you get free from your opponent?                             <ul style="list-style-type: none"> <li>- run / dodge / turn / feint / deception</li> </ul> </li> <li>Ask students with ball / without ball to go and see with partner</li> <li>Students will come up with some Use these and teach the others</li> <li>How to get away for pass?</li> <li>Importance of support and movement of person not being marked</li> </ul>
Conclusion		<ol style="list-style-type: none"> <li>Game as in 1. Challenge each player to score and to prevent direct opponent from scoring.</li> </ol>	<ul style="list-style-type: none"> <li>Getting free for the ball</li> <li>Try to avoid aimless running - only go when it's on</li> </ul>
Cool down		<ol style="list-style-type: none"> <li>Cool down is the same as warm up but use the turns taught at 2.</li> </ol>	

## Unit 4: Soccer (Shooting)

### LEARNING OUTCOMES

- The student will:**
- demonstrate an ability to create space to shoot
  - show a knowledge of when it is a good time / position to shoot
  - cooperate with others in group decision making.

### EQUIPMENT

Ball between two, cones, goals, bibs.

### CLASS ORGANISATION

## STAGE

Warm up

## CONCEPT

Development

- Creating space to shoot
- Penetration
- Support
- Keeping possession

Conclusion

Cool down

## CONTENT / ACTIVITY

Ball between two. Pass and then go away before returning for pass.

1. Increase size of area.  
Increase size of goal. Call shot game.

### 2. "Space to Shoot" game

- Each team stays in own half
- Pass until space is created to shoot
- A number of balls in each goal.

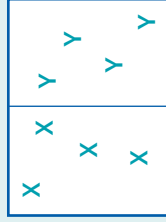

### 3. 3 v 3 Game (4 v 4 or 5 v 5)

- One player goes in goal leaving extra player on one team
- Get a shot on target. Other team gets a go.

### 4. Game as in 1.

With greater focus on getting shots on target.

5. Cool down as warm up.

## TEACHING POINTS

Eyes meet before pass given. Give when it is on. Realistic turn around before coming back for the ball.

Recap of when to pass / shoot.  
Look for accuracy and power.  
Move towards instep shot.  
Head down, knee over ball.

How can you make space for shots?

- vary passes - vary speed of passes
- shoot on sight
- set up shots

How can you work as a team with an extra player, to create scoring opportunities?

- focus on building up play
- do not just shoot from anywhere

Unit 5: Soccer (Denying space & Pressure)  
**The student will:**

- understand the importance of denying space in defensive play
- understand the importance of pressurising in defensive play
- contribute to group effort

**LEARNING OUTCOMES**

**EQUIPMENT**  
 Ball between two, cones, goals, bibs.

**CLASS ORGANISATION**

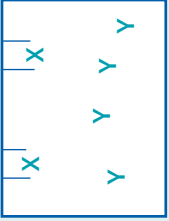
STAGE	CONCEPT	CONTENT / ACTIVITY	TEACHING POINTS
Warm up		As in Unit 4 with two additions. 1. Leave ball on command and get another ball. 2. Pressurise person on ball.	Easy pressure. No tackling. No rough play.
Development	<ul style="list-style-type: none"> <li>Defensive support</li> <li>Communication</li> <li>Denying space</li> <li>Restraint</li> </ul>	<ol style="list-style-type: none"> <li><b>5 v 5 in 30 x 40 meters</b>                              "Try not to concede" game.</li> <li><b>4 v 2 in 10 x 15 meters grid</b>                              2 try to get as many touches as possible while 4 try to keep ball.</li> <li><b>Backs v Forwards</b> <ul style="list-style-type: none"> <li>Concentrate on defending</li> <li>Alternate after five passes to forwards</li> <li>One student feeds ball to forwards.</li> </ul> </li> <li><b>Possible variation: 4 v 2</b> <ul style="list-style-type: none"> <li>2 X defend two goals</li> <li>Y's get five possessions from A</li> <li>X's must clear over line A.</li> </ul> </li> </ol> 	<ul style="list-style-type: none"> <li>What helps team to concede?                              - deny space - get behind ball - pressurise person with ball</li> <li>What should you do?                              - watch ball - Stay on one's feet                              - work as a group                              - get close                              - not necessary to win the ball</li> <li>Which space should be defended?                              - between ball and goal</li> <li>Why exert pressure?                              - stop shots and forward play</li> <li>When to challenge?                              - when the ball is outside playing distance of attacker</li> <li>At what distance is pressurising effective?                              1.5 – 2 meters</li> </ul>
Conclusion		5. Game as in 1.	
Cool down		6. Cool down as warm up.	

## Unit 6: Soccer (Challenge Cards)

### LEARNING OUTCOMES

- The student will:
- display a tactical awareness
  - cooperate with others to work for team plan
  - contribute to group decision making

### EQUIPMENT

Ball between two, cones, goals, bibs, pencils & paper.

### CLASS ORGANISATION

STAGE	CONCEPT	CONTENT / ACTIVITY	TEACHING POINTS
Warm up		No ball game. Pass by calling name. Regain possession by touching "ball carrier" before "pass" is made. Score by getting over given line.	Emphasis on movement and thinking. Restart after a score with both teams in own half.
Development	<ul style="list-style-type: none"> <li>Analysing strengths and weaknesses of opposition</li> <li>Deciding on strategies appropriate to the situation</li> <li>Using principles and concepts to achieve team plan</li> </ul>	<ol style="list-style-type: none"> <li><b>Students given challenge</b> <ul style="list-style-type: none"> <li>both teams are made aware of challenge or only tell one team</li> <li>use / adapt challenges from level 1.</li> </ul> </li> <li><b>Give the other team a challenge</b></li> </ol>	<p>Encourage students to:</p> <ul style="list-style-type: none"> <li>think up team strategy</li> <li>tell you the strategy</li> <li>play the game</li> <li>see how the strategy works</li> <li>regroup and discuss how they would change things / leave as it was, etc.</li> </ul> <p>Repeat the process.</p>
Conclusion		<ol style="list-style-type: none"> <li><b>Variation</b> <ul style="list-style-type: none"> <li>allow students to come up with the challenge</li> </ul> </li> </ol>	
Cool down		<ol style="list-style-type: none"> <li> <ul style="list-style-type: none"> <li>ball each / between two for cool down</li> <li>reaction to calls</li> <li>change calls for concentration.</li> </ul> </li> </ol>	



- Travelling
- Travelling and Balancing Weight
- Weight Transference
- Symmetry and Asymmetry
- Rotation

# Gymnastics

*jumping twisting*  
*balancing rolling*  
*turning*





Page

*Overall Aim and Objectives* ..... 264

*Teacher Guidelines* ..... 265

*Level One* ..... 267

*Learning Outcomes* ..... 268

*Content Framework* ..... 269

*Units* ..... 270

*Resource Material* ..... 276

*Level Two* ..... 291

*Learning Outcomes* ..... 292

*Content Framework* ..... 293

*Units* ..... 294

*Resource Material* ..... 300



# Overall Aim & Objectives

## **AIM**

To provide a context for an aesthetic experience and the opportunity to develop personally, socially and physically through participation in gymnastics in a safe and enjoyable environment.

## **OBJECTIVES**

- *To develop skilful, creative mastery of the body in a gymnastic context.*
- *To enhance knowledge and understanding of gymnastics as an aesthetic experience.*
- *To enrich personal and social development while interacting with others in a variety of structured contexts.*

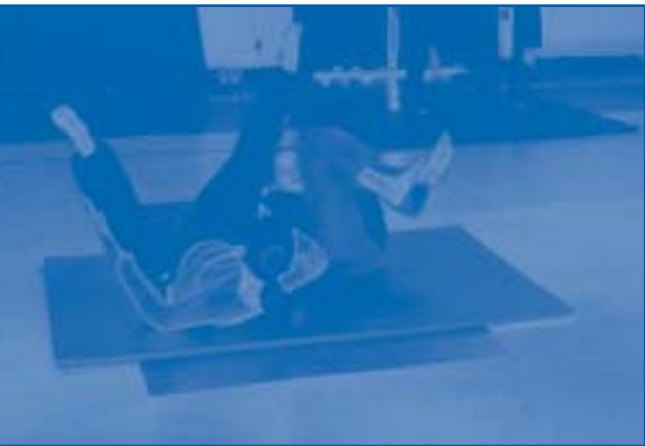

# Teacher Guidelines

*Gymnastics is one of the elements of the physical education curriculum which provides an aesthetic education for the students.*

## **METHODOLOGY**

The teaching methodology recommended is based on a problem-solving approach. This is supplemented, where appropriate, with a directive input.

## **UNIT PLANS**

The units at level 1 are divided into the following sections:

- (i) warm up and stretches
- (ii) skill learning and development
- (iii) climax
- (iv) cool down



### **(i) Warm up**

- The activities in this section should be appropriate to gymnastics.
- The warm up enables students to focus on the activity thus ensuring an appropriate attitude to work.
- The warm up should include aerobic tasks and mobility / stretching tasks appropriate to the theme of the lesson.
- Adhere to general principles of warm up.

### **(ii) Skill Learning and Development**

- Skill learning and development involves developing a gymnastic vocabulary and technical competence so that it can be used creatively in sequence work.
- This will be achieved through the selection of appropriate tasks.

### **(iii) Climax**

- The climax of the unit draws together the work of the developmental stage into sequence form.
- Students should be taught to blend actions smoothly and logically moving from one action to another recognising that the end of one action becomes the beginning of the next.
- The teacher should focus on enabling the students to come to a deeper understanding of the objectives of the unit. This includes attention to the appropriate use of space, the speed and strength of the movement and overall fluency of the sequence.
- Tasks for this section should accommodate work on small and/or large equipment. Where equipment is not available, partner work can provide the necessary movement challenge to develop this section. Equipment layout must be appropriate for the tasks.

### **(iv) Cool down**

- The cool down allows the body to recover gradually. It has a calming effect on the student enhancing her/his discipline.
- Adhere to general principles of cool down.

### **FOCUS ON QUALITY**

In planning the class the teacher can anticipate the qualitative focus appropriate to the level of the student's experience. Initially, this includes the need to develop awareness of space, body poise and muscular control. As skill and understanding develop the student begins to focus on clarity and continuity of movement. However, the teacher will need to identify the appropriate qualitative focus in relation to the response given by the student to the task in hand. In observing this response the teacher decides which qualitative focus is appropriate to the development of the task for each individual student.

### **PLANNING THE UNIT**

The learning outcomes of each unit are stated on each unit plan. A bank of tasks is supplied to assist the teacher in selecting appropriate tasks in relation to the learning outcomes of the unit.

Specific skills may arise within the class. The teacher should be competent to teach these skills to the individual student as appropriate. The teaching points and progressions for these skills are contained within the resource material.

### **CLASSROOM MANAGEMENT AND SAFETY**

It is the responsibility of the teacher to provide a safe gymnastics environment. In order to teach gymnastics successfully the following points should be considered:

- *suitable floor and safe working area. This includes good heating and ventilation.*
- *appropriate clothing for students.*
- *teacher establishes a code of practice which ensures safe participation of the students in gymnastics.*
- *students must understand that they move about without obstructing others and are conscious of their own safety and the safety of others.*
- *teachers should ensure that students know how to handle and use equipment safely. This involves knowing the correct way of lifting, lowering, pushing and pulling.*
- *all equipment should be checked for 'wear and tear' and maintained to an acceptable standard of safety.*
- *during class time it is important that the teacher is in a position to see all of the students at any given time.*
- *support for the student should only be given by the teacher.*
- *for a class group of 25 students a minimum of 12 mats will be required*
- *gymnastics tasks need to be appropriate to the class group.*

### **PARTNER WORK**

- *Partner work is a valuable learning experience for students and an essential component of the gymnastics area of study.*
- *Initially this aspect of gymnastics should be introduced as non-contact work e.g. matching, mirroring, leading, following.*
- *Teachers may wish to use partner work tasks related to objectives and themes as an integral part of each level.*

### **ASSESSMENT**

The teacher's ongoing informal observation of the student's performance is the primary mode of assessment. A formalised terminal assessment based on a sequence performed by the student could take place at the end of each level.

### **ESSENTIAL EQUIPMENT**

5/6 mats - benches.

Other gymnastic equipment, while useful, is not essential for these units.



# Gymnastics



Level  
One

*The themes chosen for level 1 are:*

- *travelling*
- *travelling and balancing weight*
- *weight transference*



## Learning Outcomes

*The student will:*

- *understand and perform appropriate actions relating to the themes of travelling, balancing weight and weight transference*
- *demonstrate control of muscular tension and body poise*
- *create and perform a short sequence based on the themes of level 1*
- *show an ability to link movements and demonstrate an understanding of the basic concepts of space and time.*



# CONTENT FRAMEWORK

1. The learning outcomes for six units have been set (see unit plans).
2. Teacher selects appropriate tasks from the bank of tasks given and includes the qualitative aspects suggested below.

## Unit 1

TASKS	QUALITATIVE ASPECT	OBSERVE
Tasks to include	Space: general / personal / directions Time: moving / stopping quick / slow	Correct technique for actions. Use of directions.

## Unit 2

TASKS	QUALITATIVE ASPECT	OBSERVE
Tasks to include	Space: general / personal / directions Time: moving / stillness	Muscular tension: to outline shape / to hold stillness.

## Unit 3

TASKS	QUALITATIVE ASPECT	OBSERVE
Tasks to include	Space: general / personal Time: stillness / moving	Correct muscular tension to hold stillness. Appropriate speed to link 2 actions.

## Unit 4

TASKS	QUALITATIVE ASPECT	OBSERVE
Tasks to include	Space: changes of direction Time: fast / slow. Stillness / moving moving with change of direction in action	Moving fast / slow into and out of actions. Correct muscular tension to maintain weight bearing positions

## Unit 5

TASKS	QUALITATIVE ASPECT	OBSERVE
Tasks to include	Space: changes in direction and use of levels Time: stillness / moving fast / slow	Selection of appropriate actions. Imaginative use of levels. Good muscular tension. Appropriate linking of actions. Correct technique.

## Unit 6

Assessment Student performs sequence. Student/teacher observation.		
--------------------------------------------------------------------------	--	--

Unit 1: Travelling

**LEARNING OUTCOMES**

**The student will:**

- develop skill in travelling actions using feet, hands and feet and whole body
- use space with focus on safety and directions.

**EQUIPMENT**

**CLASS ORGANISATION**

**STAGE**

Warm up & Stretches

Development

Climax

Cool down

**CONTENT / ACTIVITY**

**FOCUS ON QUALITY**



## Unit 2: Travelling & balancing weight

### LEARNING OUTCOMES

#### The student will:

- extend vocabulary in relation to travelling using changes in direction
- explore supporting weight using large body surfaces and combinations of small body parts
- link travelling action with supporting weight action.

### EQUIPMENT

### CLASS ORGANISATION

STAGE	CONTENT / ACTIVITY	FOCUS ON QUALITY
Warm up & Stretches		
Development		
Climax		
Cool down		

Unit 3: Balancing weight & travelling

**LEARNING OUTCOMES**

**The student will:**

- extend experience of weight bearing by moving into and out of balances
- explore the use of speed (quick / slow) moving into and out of balances.

**EQUIPMENT**

**CLASS ORGANISATION**

STAGE	CONTENT / ACTIVITY	FOCUS ON QUALITY
Warm up & stretches		
Development		
Climax		
Cool down		

Unit 4: Weight transference

**LEARNING OUTCOMES**

**The student will:**

- explore the transference of weight, moving from one body part to another body part
- focus on appropriate use of speed and direction.

**EQUIPMENT**

**CLASS ORGANISATION**

STAGE	CONTENT / ACTIVITY	FOCUS ON QUALITY
Warm up & stretches		
Development		
Climax		
Cool down		

Unit 5: Weight transference

**LEARNING OUTCOMES**

**The student will:**

- develop linking actions using the recovery of one action to prepare for the next action
- select movements based on travelling, balancing weight and weight transference to create a sequence.

**EQUIPMENT**

**CLASS ORGANISATION**

STAGE	CONTENT / ACTIVITY	FOCUS ON QUALITY
Warm up & stretches		
Development		
Climax		
Cool down		

Unit 6: Weight transference/assessment

**LEARNING OUTCOMES**

The student will:

- refine and perform their sequences for assessment
- observe and discuss the sequence of others in relation to actions, use of time and space.

**EQUIPMENT**

**CLASS ORGANISATION**

STAGE	CONTENT / ACTIVITY	FOCUS ON QUALITY
Warm up & stretches		
Development		
Climax		
Cool down		

## TRAVELLING TASKS

1. Run about the space and stop on command.
2. Run on the spot, on signal change to using space. Repeat several times.
3. Run using large steps, on signal change to using small steps.
4. Run sideways. Run backwards.
5. Run changing direction on signal.
6. Find different ways of travelling round the room on feet only, e.g. hopping, skipping, galloping, jumping.
7. Start travelling on feet one way and on signal change to another.
8. Jump and land on the spot, concentrating on resilient landings.
9. Jump backwards forwards and sideways with resilient landings.
10. Jump as high as possible on the spot.
11. Jump taking off from one foot and landing on two.
12. Move about the space using hands and feet.
13. Move on hands and feet concentrating on having different parts of the body facing upwards e.g. back, sides, hips.
14. Travel on hands and feet moving forwards, backwards and sideways.
15. Travel on hands and feet with changes in speed.
16. Travel on hands and feet moving from two hands to two feet.
17. Travel on hands and feet getting hips high.
18. Travel on hands and feet by placing hands on the floor on either side of the body.
19. Travel on hands and feet by changing the position of the feet e.g. close to hands, to the side of the hands, far away from the hands.
20. Link together three different ways of travelling on feet.
21. As above, but make a change of direction when changing ways of travelling.
22. Roll across the mat in different ways, sideways, stretched out, tucked up.
23. Roll and finish in a different position, e.g. on two feet, one foot, knees, hips, shoulders.
24. Roll starting from different positions.
25. Roll starting in one position and finish in another.
26. Begin on shoulders, roll down back and finish on feet, roll back onto shoulders.
27. Perform the same action, first very slowly and then quickly.
28. Perform three different rolls, moving from slow to quick to slow.
29. Link a jump, a roll and an action on hands and feet.
30. Choose three different types of travelling actions and make up a sequence using each action.
31. Take a full turn jump, land and roll forwards.
32. Take a half turn jump, land and roll backwards.
33. Take a quarter turn jump, land and roll sideways.
34. Take a half turn jump, land and roll backwards, half turn jump land and roll forwards.

## TRAVELLING EQUIPMENT

1. Transfer feet actions to benches and mats, e.g. running, skipping, hopping, jumping.
2. Combine different travelling actions, along, over and across the bench.
3. Run and jump over the bench.
4. Run along the bench and jump off the end.
5. Run half way along the bench and jump off sideways.  
Zigzag jumping over the bench, using one foot to two feet.
6. Zigzag over the bench, using two feet to two feet.
7. Spring from one foot to the other along the bench.
8. Gripping the side of the bench, travel along using hands and feet.
9. Grip the side of the bench with hands and travel along springing feet from side to side of the bench.
10. Travel along the bench turning while using hands and feet.
11. Travel half way along the bench on hands and feet, then find an action with which to move away from the bench.
12. Combine different travelling actions using feet to move from one end of the bench to the other.
13. Slide along the bench.
14. Slide to the middle of the bench, spin and roll off.

15. Roll to travel parallel to the bench, turn and cross over the bench.
16. Roll to arrive on bench and travel away from bench.
17. Roll towards bench turn and travel along the bench.
18. Link different actions to travel along the bench, across the mat and away from the mat.
19. Link a jump, a roll, an action on hands and feet using bench, mat and floor.





**BALANCING WEIGHT TASKS**

1. Support your weight on large body parts, e.g. back, hips, shoulders, side, front.
2. Put weight on one part of the body and hold still.
3. Put weight on one body part, hold still then transfer weight to another body part and hold still.
4. Find a way to move into a balance on one body part, hold still and find a way to move back to feet.
5. Select three large body parts to balance on and move from one to the other, holding still on each one. Identify starting and finishing position.
6. Balance on one part of the body and lift some other part high, change the balance and lift another part high.
7. Support weight on small body parts, e.g. combination of feet and hands, two feet and two hands, two feet one hand, one hand two feet.
8. Balance so that there are four/three/two parts of the body in contact with the floor.
9. Choose two different balances using hands and feet and find a way to move from one to the other.
10. Choose two different balances, one using hands and feet and one using a large body part and find a way of moving from one to the other with a roll, finish on feet.
11. Choose two different balances, one showing a stretch and one showing a tucked shape. Find a way to move from one to the other.
12. Perform a balance three times in sequence and link them together with a different movement.
13. Support weight on hands only keeping body in a tucked position.
14. Support weight on hands so that one leg is stretched in the air while the other lifts off the floor.
15. Support weight on hands while the body is extended.
16. Support weight on hands, transfer back to feet and move into another balance.
17. Create a sequence of three balances using a different shape for each balance.
18. Create a sequence of three balances which includes a balance on hands an inverted balance and a balance on some other part and link them with a jump or a roll.



**WEIGHT TRANSFERENCE TASKS**

1. Step onto one foot and pivot on that foot. Continue pivoting on alternate feet.
2. Step, pivot, step into a turning jump.
3. Travelling round the room, spring from one foot to the other in a continuous action.
4. Lower body weight slowly to the floor and return to feet.
5. Take weight onto one part of the body and change to another before returning to feet.
6. Lower weight on feet first, roll onto hips, over one knee and back to feet.
7. Lower weight to a part of the right side of the body, then transfer to the left side and return to feet.
8. Find two parts of the body close to each other and rock from one to the other. Gradually increase speed.
9. Explore other parts of the body on which to rock.
10. Rock, build up speed and roll out of rocking action. Repeat.
11. Take weight on shoulders, body tucked up, rock, to land on feet. Repeat but land on feet from a different direction.
12. Combine different rocking and rolling actions and make them continuous.
13. Practice rolling forwards, backwards sideways using different starting and finishing positions.
14. Start rolling facing one direction and finish facing another.
15. Practice rolling using different combination of body parts.
16. Practice rolling using different body shapes.
17. Step, roll and spin.
18. Create a sequence using hands and feet, a spin and a roll in any order.

19. Taking weight on hands, take off from one foot, and swing leg high into the air.

20. As in 19 but change position of legs in the air and land on the other foot.

21. Practice jumping from two feet to two feet, one foot to the other foot, one foot to two feet, two feet to one foot and one foot to the other.

22. Select a jump showing a wide/narrow/tucked up shape and link it with a roll.

23. Select a turning jump and link it with a roll which has a change of direction.

**WEIGHT TRANSFERENCE SMALL EQUIPMENT**

1. Grip the bench and travel over getting hips high by taking off from one foot to land on two feet. Repeat from one end of the bench to the other.

2. Travel over the bench using hands on the bench and taking off from one foot to land on two feet on the other side of the bench.

3. Cross the bench or low equipment without touching it to take weight on hands on the landing side.

4. Cartwheel over the bench with hands on the bench or floor.

5. Start on the bench and roll onto the mat.

6. Roll towards the bench and jump to land on the bench.

7. Roll along the bench, move into a jump, staying on the bench all the time.

8. Grip the side of the bench with hands and travel along, taking off from one foot and landing on two feet.

9. Grip the bench with hands and travel over getting hips high by taking off from two feet and landing on two feet. Move from one end of the bench to the other in this way.



## WARM UP & COOL DOWN TASKS

### WARM UP TASKS

**When using these tasks the teacher should adhere to the general principles of warm up and cool down.**

- 1 Run on the spot and travel round the room on signal.
- 2 As above in 1, but use long strides in travelling and small steps on the spot.
- 3 Run and on signal touch floor with either hand and then with both.
- 4 Run making straight lines, zigzag lines and turning corners.
- 5 Run making curves, circles and spirals.
- 6 Run, contrasting heavy and light, fast and slow and stop and start.
- 7 While running circle and shake arms, wrists and hands.
- 8 On signal, alternate running with bouncing on the spot.
- 9 Run forwards, sideways and backwards, looking in the direction you are travelling.
- 10 Heel raising and lowering alternately.
- 11 Kneeling hands on the ground, circle legs alternately.
- 12 From sitting flex and stretch ankles.
- 13 Standing, feet astride circle hips.
- 14 From kneeling walk hands as far round as possible to alternate sides.
- 15 Sit with legs straight and rotate ankles reaching as far as possible in both directions.

### COOL DOWN TASKS

- 1 Lie on stomach, hold hands behind back and raise chest.
- 2 Lie on front, raise chest and legs at the same time.
- 3 Kneeling with hands on the floor, reach under one arm with the other, twisting to reach as far as possible.
- 5 Place hands and knees on floor and gently push body over arms. Hold and release and repeat exercise.
- 6 Lie on back, knees bent, feet on floor, arch back to take weight on shoulders and feet, hold, slowly return to lying into full stretch.
- 7 Kneel on the floor, stretch arms forward and place hands on the floor push the chest to the floor while hips remain high in the air.
- 8 Sit straight up, soles of feet pressed flat together. Hold the feet with hands and gently press the knees down towards the floor.
- 9 Sit with legs stretched out in front and together. Bend the body forwards, gently press the chest to the knees.
- 10 Lying on stomach, stretch arms and legs out and away from floor, hold position roll onto side balancing on hips and stretch arms and legs floor. Move from that position into a V shape on the hips.
- 11 Rocking from side to side on back, arms and legs extended, build momentum to roll sideways.
- 12 Sitting on floor, legs together and stretched out in front. Rock from side to side taking weight onto right and left hands alternately. Build momentum to complete a full turn to right or left.
- 13 In pairs, walk in a large circle. On signal, students in outer circle change directions, continue walking.
- 14 Slowly and lightly run and change to walking.
- 15 Breathe deeply while walking.
- 16 Walk in circle round self.
- 17 Walk around gym, meet with partner, continue to walk in silence.
- 18 Walk in a zigzag pathway round gym.
- 19 While walking, circle arms slowly forwards and backwards.
- 20 With partner, standing, stretch calf/quadriceps/hamstring muscles.
- 21 Circle arms forwards slowly.
- 22 Stretch arms up over head.
- 23 Stretch chest by clasping hands behind back.
- 24 Stretch biceps by extending arms down.
- 25 Lie on the mats and relax.
- 26 Lie on the mats and tense whole body, hold for a count of five and relax. Repeat.

# SPECIFIC SKILLS

The following skills will arise in gymnastic work no matter what teaching approach is used. It is necessary for teachers to be fully aware of the teaching points for these skills, the difficulties which students experience in performing these skills, progressions and variations which provide challenge and ensure development in movement vocabulary.

## FORWARD ROLL

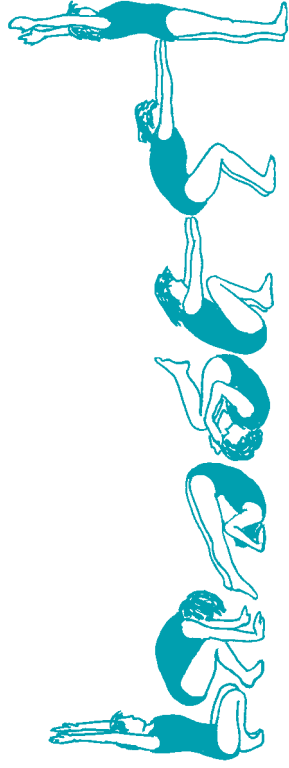

1. Begin in a crouched position, arms reaching out.
2. Take weight on hands, which are flat on the floor, shoulder width apart, fingers facing forwards
3. Seat is lifted, head tucked in so that contact with the ground is made with back of the head
4. Strong push from the feet, arms bend to provide a change of balance resulting in a forward rolling movement
5. Body remains tucked with rounded back
6. Put feet on floor close to hips
7. Reach forward with arms and come up to standing.

## DIFFICULTIES WITH FORWARD ROLL



Discomfort in rolling . . . may result from placing head on the floor or rolling with a straight back



Rolling in a crooked line . . . can be the result of an uneven push from the hands or the head turned sideways during the roll



Failure to finish on feet . . . can be caused by the hands incorrectly placed on the floor or the feet positioned too far from the hips at the end of the roll.



Unable to move forward into roll . . . can be insufficient push from the legs at the initial stage

## VARIATIONS FOR FORWARD ROLL



**Rolling into different finishing positions:**

- into straddle stand / sit
- onto two knees/feet
- into back lying
- into handstand / headstand



**Rolling from different starting positions:**

- from standing straddle
- from a jump
- from a balance
- from one / two feet
- from one knee
- from handstand / headstand

## BACKWARD ROLL



1. Begin in a crouched position, hands out in front ready to be placed beside head.
2. Sit back onto seat, hips close to feet.
3. Place hands in position early, flat on floor, close to head, fingers pointing towards feet, thumbs to ears.
4. Back rounded, tuck in tightly.  
As hips move over head push hard from hands, remain tucked
5. Maintain push, land on balls of feet.

## DIFFICULTIES WITH BACKWARD ROLL



Unable to get to feet / or move backwards . . . opening out too early in the movement.



Weak push . . . can be caused by hands incorrectly placed.



Crooked roll . . . is the result of an uneven push from hands.



Unable to complete the roll . . . due to lack of momentum. Practise rocking backwards and forwards emphasising heels close to hips, chin to chest.

## VARIATIONS FOR BACKWARD ROLL

**Rolling to different finishing positions:**

- to one foot / two feet
- to front support
- to hands and knees



**Rolling from different starting positions:**

- from straddle position standing / sitting
- from two feet / one foot sitting / standing
- from a 'V' sit with knees tucked
- from a jump

**HEADSTAND**

1. In a kneeling position place hands, shoulder width apart, and forehead on floor in an equilateral triangle.
2. Hands flat on the floor, fingers facing forward, walk feet up towards hands until weight moves over head and hands.
3. Push down on hands, with feet tucked lift hips into tucked headstand.
4. Keep back straight, weight balanced between head and hands, straighten legs.



**DIFFICULTIES WITH HEADSTAND**



Overbalancing . . . caused when back of head is on floor or hands and head are too close together.

Headstand collapses . . . this occurs when the back is not straight or the legs are straightened too soon.

Failure to invert . . . results when legs are straightened before weight is balanced over base.

**VARIATIONS FOR THE HEADSTAND**

**Headstand from different starting positions:**

- from standing / kneeling
- from one foot / one knee
- from straddle position.

**Headstand into different finishing positions:**

- into forward roll (with progression)
- into handstand.

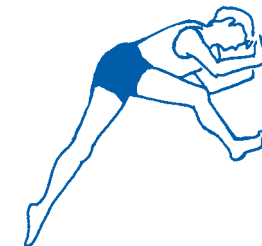
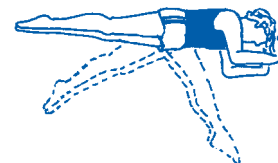



## HANDSTAND

1. Stretched standing position, arms shoulder width apart.
2. Take long lunge step forward placing hands flat on floor fingers slightly spread and facing forward.
3. Back leg swings up straight, weight moves over shoulders.
4. Arms kept straight pushing against floor.
5. Second leg swings up to join first.
6. Body remains tight and straight.



## DIFFICULTIES WITH HANDSTAND

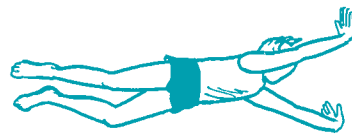

Handstand collapses . . . caused by bending the arms or placing the hands too far apart. Inability to balance . . . due to lack of tension in the body.



Inability to invert . . . head looking forward or weight not fully over hands.



Hyper-extension of the spine . . . due to weak abdominal muscles.

## VARIATIONS FOR THE HANDSTAND

### Handstand into different finishing positions:

- into forward roll (with progression)
- onto one foot / two feet
- finishing in (different) starting position.

### Handstand from different starting positions:

- from one / two feet take off
- from one / two knees
- from headstand
- from one hand and one knee.

### Handstand with variations in leg shape

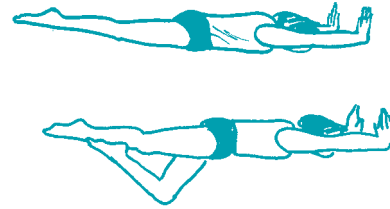

**CARTWHEEL**

1. Start facing forward, arms stretched high, close to ears.  
Strong step forwards, toe pointing in direction of the action.
2. Chest down to knee of bent leg, hands at right angles to line of action.
3. Push hard from bent leg, swing other leg up, wide straddle of legs.
4. Arms straight, head looking at floor, eyes down.
5. Hands and feet should contact the floor in a straight line.
6. As body comes upright arms should still be high, close to ears.

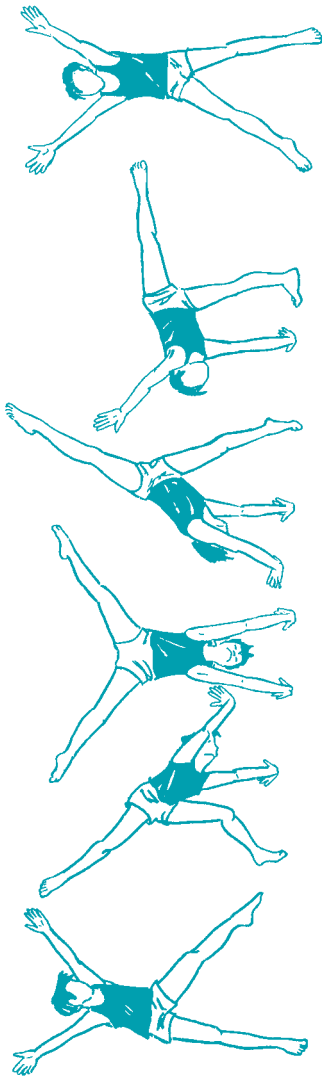

**DIFFICULTIES WITH THE CARTWHEEL**

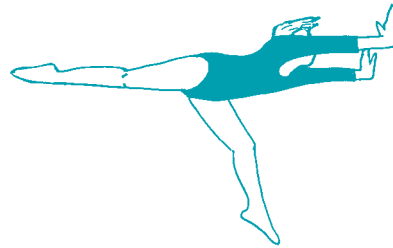

Unable to move sideways . . .  
due to incorrect sequence of  
hands and feet.



Inability to invert . . .  
caused by poor body  
position or legs not lifting

**VARIATIONS FOR THE CARTWHEEL**

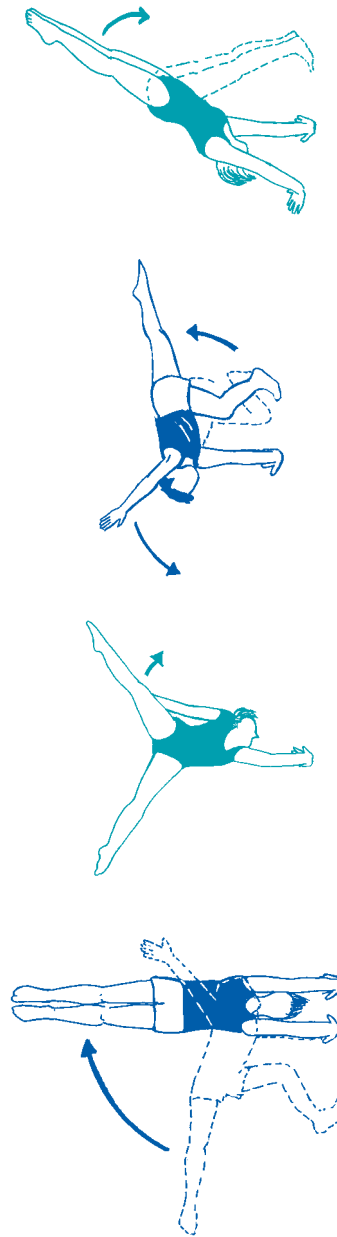

- Cartwheel in either direction
- Cartwheel using one hand only
- Cartwheel from half kneeling position
- Cartwheel from balancing on one knee
- Cartwheel to finish on one knee
- Cartwheel to finish one two feet simultaneously

## JUMPING

### TAKE OFF

- Good arm swing aids jumps.
- Arm swing comes from behind the line of the body.
- Thrust is created by simultaneous straightening of the hip, knee and ankle joints with a forward swing of the arms.
- Head up, shoulders relaxed, full extension shown at start and finish.

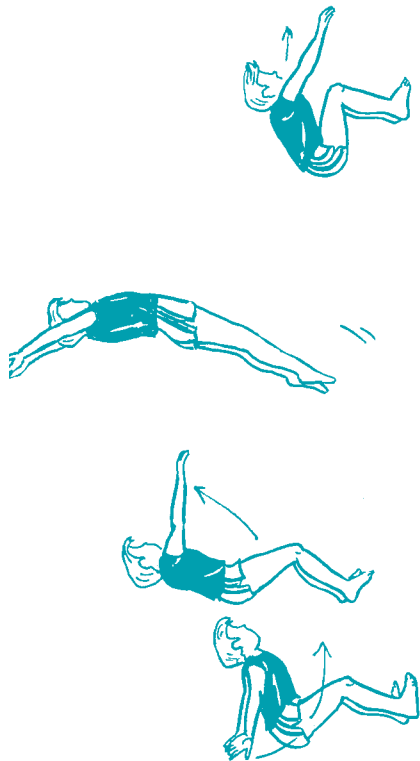

### LANDING

- Feet slightly ahead of the body to establish a secure landing.
- Land on the balls of the feet, lowering the heels with a slight bend of the knees.
- The bottom is above the heels and the back is straight.
- Jumping practices should begin on the spot first, followed by a couple of steps into a jump and finally after a run into a jump.
- Mats should be provided to absorb the shock of the landing.



## DIFFICULTIES WITH JUMPING

Unstable landing . . . can be caused by rigid joints (hips, knees, ankles) or deep knee bend which results in heels lifting up or by feet not being placed ahead of body.



Poor height . . . due to lack of arm swing or poor push from feet.

## VARIATIONS IN JUMPING

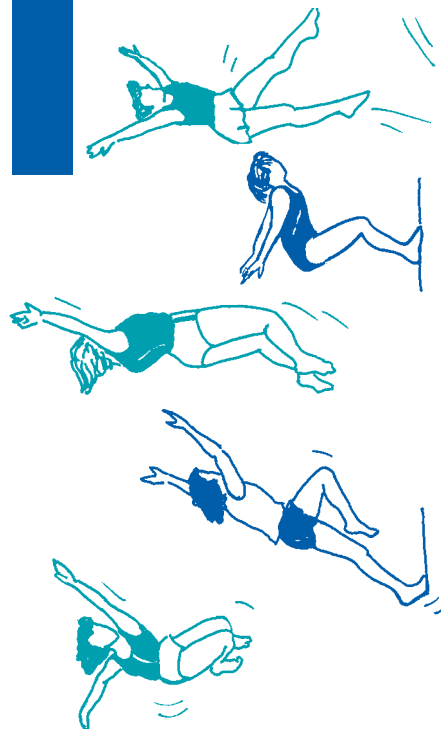

Different take-offs, one foot to two feet, etc.

Different shapes . . . stretch jump, upward jump with full extension, wide jump, star jump.

Turning jumps . . . half turns, full turns.





# Gymnastics



Level  
Two

Through selected themes, the students enhance their understanding and performance of gymnastics.

The themes chosen for level 2 are:

Symmetry / Asymmetry

Rotation

## Learning Outcomes

The student will:

- understand and perform appropriate actions relating to the themes of symmetry, asymmetry, twisting & turning and rotation
- refine the technical competence of their actions
- develop an understanding of the use of time and space
- demonstrate the ability to select, create and perform a gymnastic sequence
- observe and analyse the work of others.

### ASYMMETRY

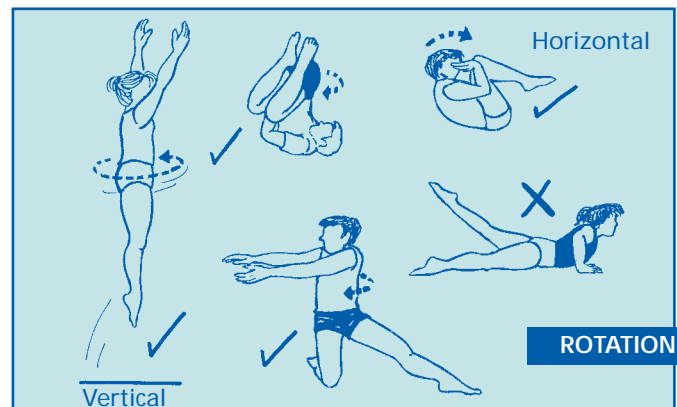
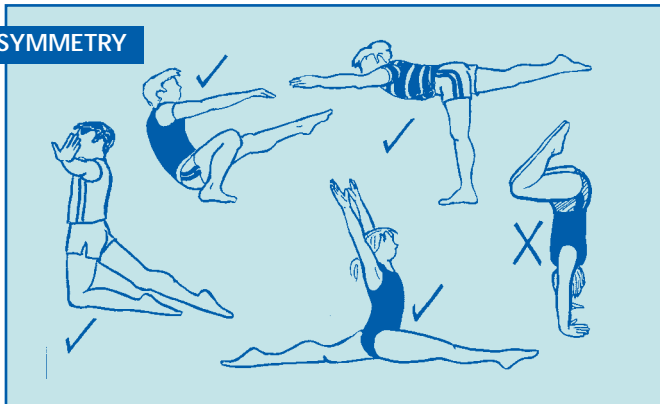

Using horizontal and vertical axes

### SYMMETRY

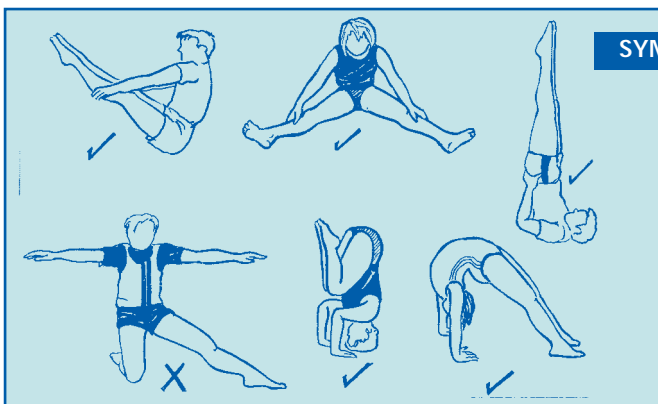

# CONTENT FRAMEWORK

Level 2 gymnastics programme uses a thematic approach. Each unit identifies a specific focus and a bank of tasks is included through which students can explore the theme.

## UNIT 1

*Symmetry and Asymmetry through:*

- *travelling*
- *moving into and out of balances*
- *linking two or more actions.*

## UNIT 2

*Symmetry and asymmetry through:*

- *weight transference*
- *changes in speed*
- *linking two or more actions into a sequence.*

## UNIT 3

*Twisting and turning through:*

- *balance*
- *changes in levels*
- *changes in pathways*
- *sequence linking twisting and turning.*

## UNIT 4

*Rotation through:*

- *vertical axis*
- *horizontal axis*
- *lateral axis*
- *sequence using axis.*

## UNIT 5

*Plan a sequence through:*

- *selection of actions from different themes*
- *use of pathways*
- *use of levels*
- *use of speed.*

## UNIT 6

*Sequence work:*

- *refining sequence*
- *perform sequence*
- *observe and analyse sequence.*

## Unit 1: Symmetry and asymmetry

### LEARNING OUTCOMES

#### The student will:

- travel symmetrically and asymmetrically
- move into and out of symmetrical and asymmetrical balances
- link two or more actions demonstrating the contrast between symmetry and asymmetry.

### EQUIPMENT

Mats, benches, large equipment, workcards.

STAGE	CONTENT / ACTIVITY	FOCUS ON QUALITY
Warm up and Stretches		
Development		
Climax		
Cool down		



Unit 2: Symmetry and asymmetry

**LEARNING OUTCOMES**

- The student will:**
- develop symmetrical and asymmetrical actions using weight transference
  - learn the use of acceleration and deceleration to move into and out of these actions
  - select and link two or more of these actions appropriately.

**EQUIPMENT**

Mats, benches, large equipment, workcards.

STAGE	CONTENT / ACTIVITY	FOCUS ON QUALITY
Warm up and stretches		
Development		
Climax		
Cool down		

### Unit 3: Twisting and turning

#### LEARNING OUTCOMES

#### The student will:

- twist into and out of balance
- turn into and out of balance with twisting and turning actions
- develop a sequence using actions of twisting and turning.

#### EQUIPMENT

Mats, benches, large equipment, workcards.

STAGE	CONTENT / ACTIVITY	FOCUS ON QUALITY
Warm up and stretches		
Development		
Climax		
Cool down		

## Unit 4: Rotation

### LEARNING OUTCOMES

- The student will:
- develop rotation actions through use of axis
  - link two actions using vertical axis
  - link two actions using lateral axis
  - link two actions using horizontal axis
  - link rotation actions using a variety of axes.

### EQUIPMENT

Mats, benches, large equipment, workcards.

STAGE	CONTENT / ACTIVITY	FOCUS ON QUALITY
Warm up and stretches		
Development		
Climax		
Cool down		

## Unit 5: Development of sequence

### LEARNING OUTCOMES

- The student will:**
- plan a sequence by selecting actions from the themes of symmetry/asymmetry, balance, rotation, twisting/turning
  - select pathways, levels and speed appropriate to the actions of the sequence
  - plan the sequence taking account of the equipment layout provided.

### EQUIPMENT

Mats, benches, large equipment.

STAGE	CONTENT / ACTIVITY	FOCUS ON QUALITY
Warm up and stretches		
Development		
Climax		
Cool down		

Unit 6: Sequence work/assessment

**LEARNING OUTCOMES**

- The student will:**
- refine and perform sequence
  - observe and analyse another student's sequence.

**EQUIPMENT**

Mats, benches, large equipment.

STAGE	CONTENT / ACTIVITY	FOCUS ON QUALITY
Warm up and stretches		
Development		
Climax		
Cool down		

### SYMMETRY & ASYMMETRY TASKS

- 1 Travel symmetrically using feet.
- 2 Travel asymmetrically using feet.
- 3 Bounce up and down symmetrically using feet.
- 4 Bounce feet in and out symmetrically.
- 5 Bounce on the spot symmetrically and travel forwards asymmetrically.
- 6 As in 5 but travel in different directions.
- 7 Take weight on a large surface and create a symmetrical balance / asymmetrical balance.
- 8 Balance on four points, making a symmetrical shape and move out of this balance.
- 9 Balance on three body points, making an asymmetrical shape and move out of this balance.
- 10 Balance in a tucked up symmetrical shape and move out to standing.
- 11 Balance in a stretched symmetrical shape and move to standing.
- 12 Balance in an asymmetrical shape and move out sideways.
- 13 Create a sequence which combines symmetrical and asymmetrical balances and uses changes of direction moving out of these balances.
- 14 Roll symmetrically, transfer weight to feet and jump asymmetrically.
- 15 Transfer weight from feet to hands to feet travelling forwards / backwards symmetrically
- 16 Transfer weight from feet to hands to feet asymmetrically by placing hands to the side of the body.

- 17 Rock between two body parts and move to feet symmetrically.
- 18 Roll asymmetrically, transfer weight to feet and jump symmetrically.
- 19 Rock symmetrically into a roll and continue rocking asymmetrically.
- 20 Balance symmetrically on hips, transfer weight by rocking into an asymmetrical balance on some other part of the body.
- 21 Transfer weight from a symmetrical balance to an asymmetrical one.
- 22 Make a sequence using symmetry and asymmetry which includes two hands and feet actions and two balances.

### SYMMETRY & ASYMMETRY EQUIPMENT

- 1 Run towards bench, jump on and off symmetrically
- 2 Run towards bench jump on and off asymmetrically.
- 3 Travel along bench using hands and feet symmetrically. Repeat travelling asymmetrically.
- 4 Cross the bench using hands and feet/ whole body symmetrically. Repeat travelling asymmetrically.
- 5 Balance on the bench symmetrically, move onto floor and roll away asymmetrically.
- 6 Create a balance between the equipment and mat using symmetrical / asymmetrical shape. Find a way of moving out of these balances and away from the mat.
- 7 Balance either symmetrically/ asymmetrically away from the equipment, travel towards the equipment and balance on the equipment symmetrically / asymmetrically.

## SYMMETRY &amp; ASYMMETRY EQUIPMENT CONT.

- 8 Travel towards equipment symmetrically, use hands to get onto the equipment asymmetrically and balance asymmetrically.
- 9 Spring asymmetrically from the equipment, travel symmetrically to another piece of equipment, get on and balance asymmetrically.
- 10 Practise springing onto and off the equipment on hands and feet using symmetrical/asymmetrical actions.
- 11 Roll onto/along/off the equipment using symmetrical / asymmetrical actions.
- 12 Spring onto the equipment with an asymmetrical action transfer weight onto another part of the body and come off the equipment with a symmetrical movement.
- 13 Spring onto the equipment using hands transfer weight on the equipment, using an asymmetrical action and get off using an asymmetrical action.
- 14 Spring onto the equipment landing on some body part other than feet transfer weight onto feet using a symmetrical action and spring off asymmetrically.
- 15 Link movements ontover/across/along different pieces of equipment using symmetrical and asymmetrical actions.

## SYMMETRY &amp; ASYMMETRY EXTRA TASKS

For further ideas of tasks refer to themes in unit 1 and in particular to the themes of balance and transference of weight

### ROTATION TASKS

- 1 Travel around the room turning and sliding alternately.
- 2 Step onto one foot and pivot on that foot(vertical). Repeat action on other foot (vertical).
- 3 Explore jumping and include different degrees of turning.(vertical)
- 4 Turning jumps taking off from one foot and landing on two feet.
- 5 Develop a short sequence of turning jumps moving from one to two feet.
- 6 Create a sequence which includes turning jumps and pivots.
- 7 Turning by wheeling actions on hands and feet, repeat to both sides.(lateral)
- 8 Practise a turning jump (vertical) which finishes with a wheeling turn.(lateral)
- 9 Practise a rolling turn (horizontal) which finishes in a jumping turn.(vertical)
- 10 Practise a wheeling turn which finishes in a rolling turn.
- 11 Create a sequence of three turns which include a pivotal turn, a wheeling turn and a jumping turn.
- 12 Travel to your mat, cross over it and then leave it using different turning actions.
- 13 Wheel across the corner of the mat, land and use a turning spring into the centre and rebound with a turn.
- 14 Start with weight on some part of the body (other than feet) transfer weight with a turn to arrive on the mat and another turn to cross the mat.
- 15 Explore ways of turning into and out of balances.

- 16 Explore ways of pivoting into different balances using different body parts to pivot on.
- 17 Travel, turning on hands and feet, turn into a balance and return to feet.
- 18 Develop a sequence which moves out of a balance by turning, into travelling and turning into a balance.
- 19 Find ways of balancing on small parts of the body, twist out of balances and return to feet.
- 20 Find ways of inverting balances and twisting out of them so that feet meet the floor first.
- 21 Find ways of rolling into a balance and twisting out of it.
- 22 Pivot on the mat into a balance, twist out of it onto feet and spring into a turn.
- 23 Take weight onto knees, twist body and move from that twist into a pivotal turn.

### ROTATION USING EQUIPMENT

- 1 Balance on bench, transfer weight onto hands and turn away from bench.
- 2 Move towards the bench with a turning action, balance on bench and move off bench with a twisting action.
- 3 Turn across the bench and finish with an inverted balance on the mat.
- 4 Cross the bench with a turn by putting one hand on the bench and one on the floor the far side of the bench.





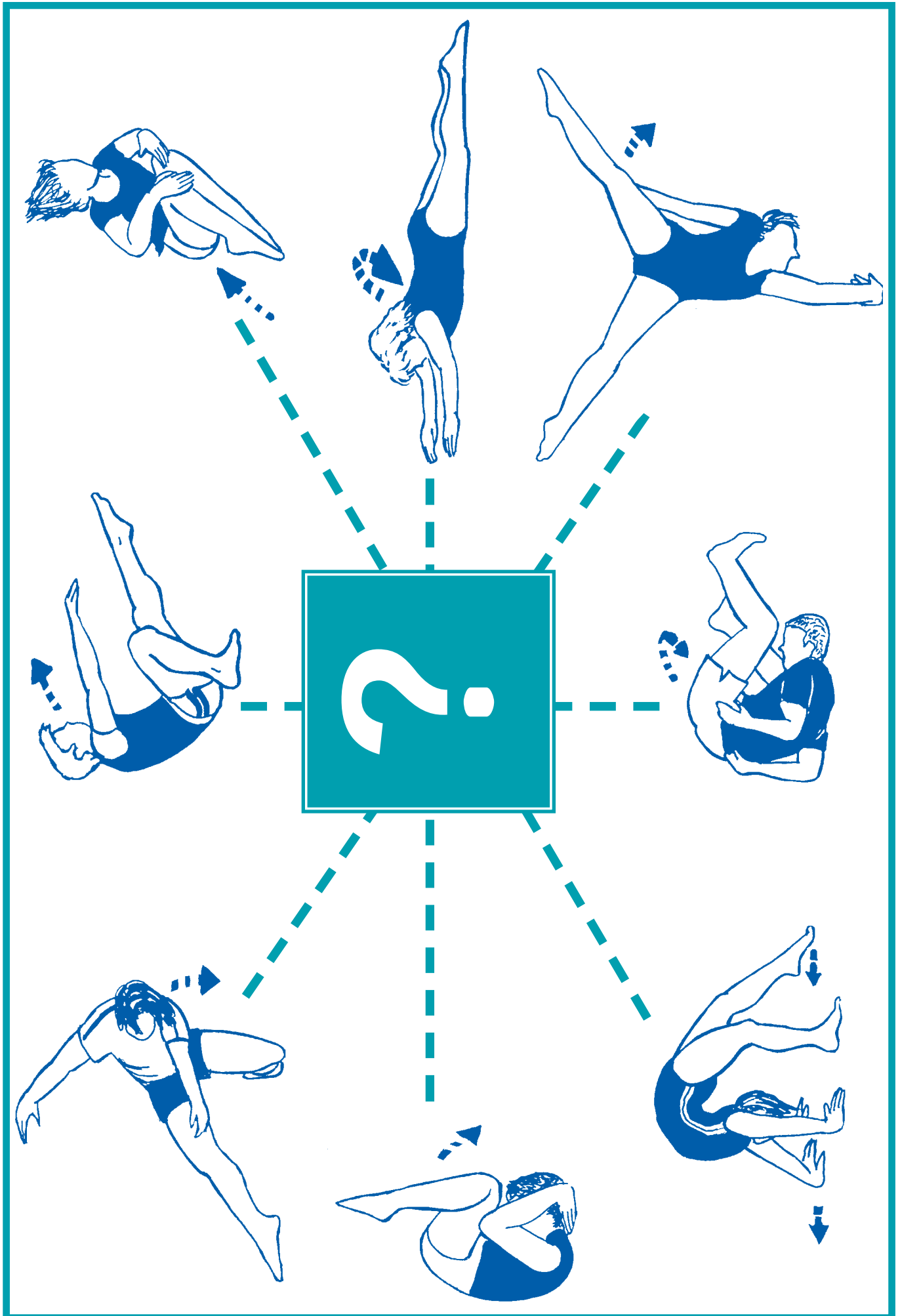

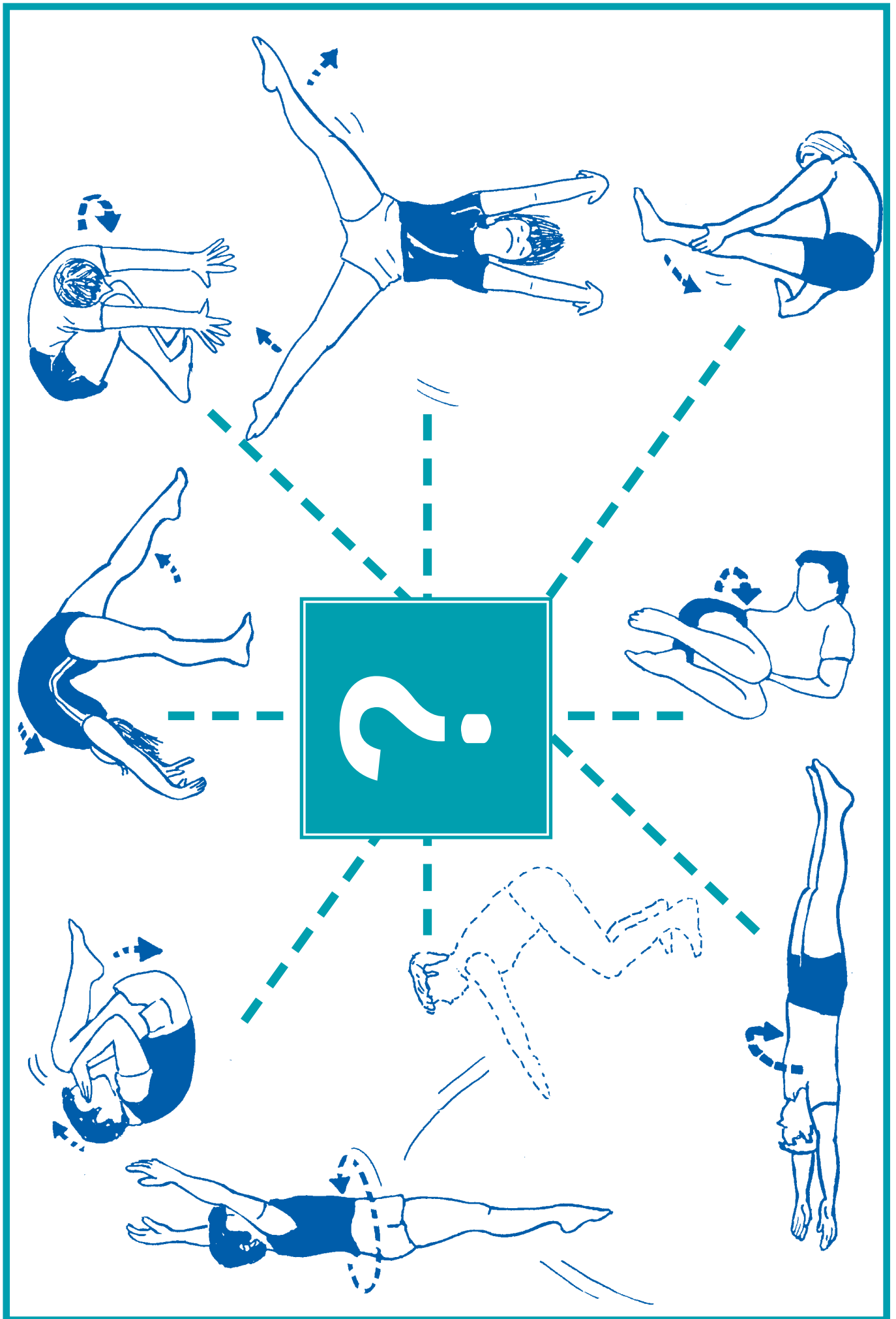

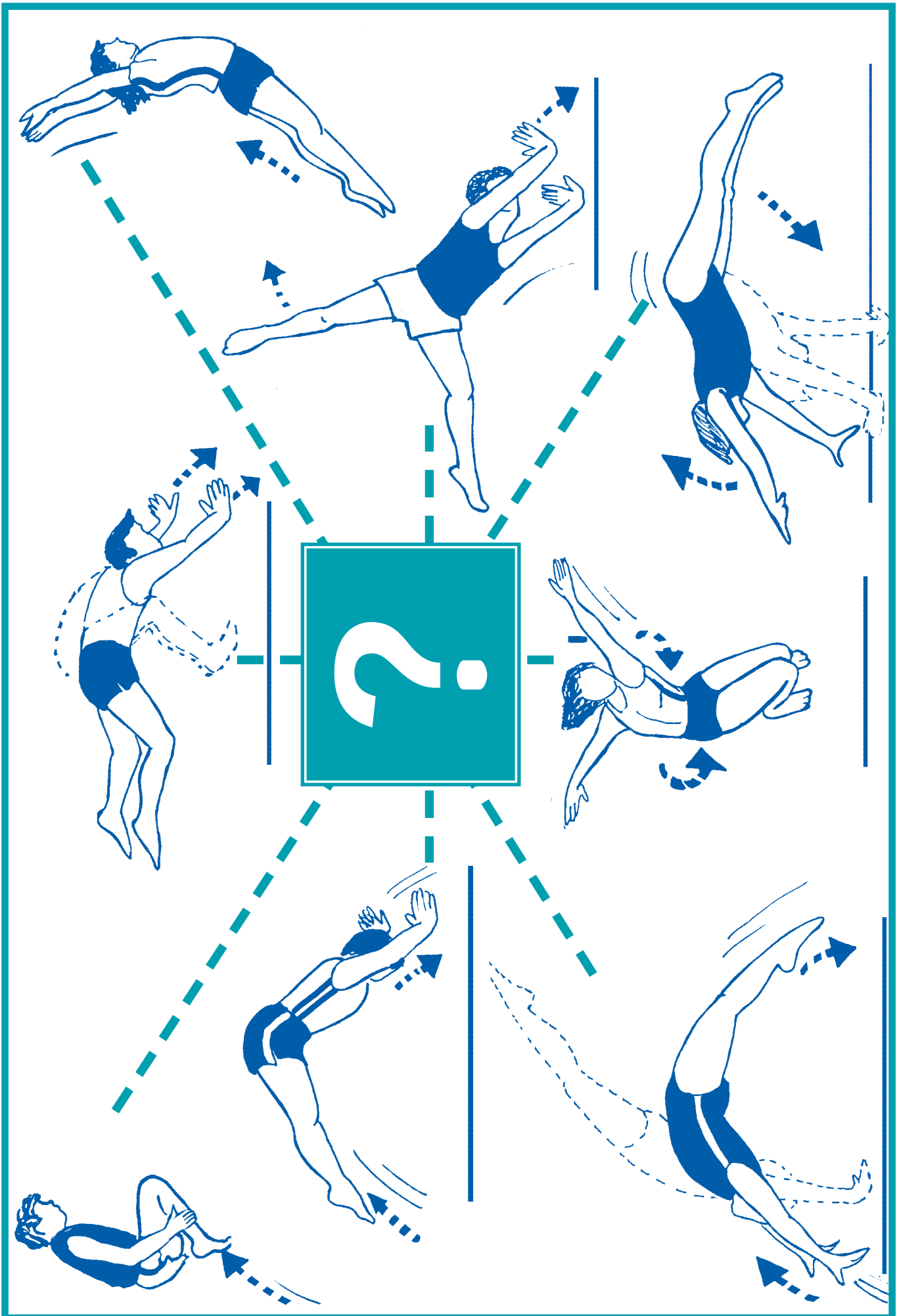

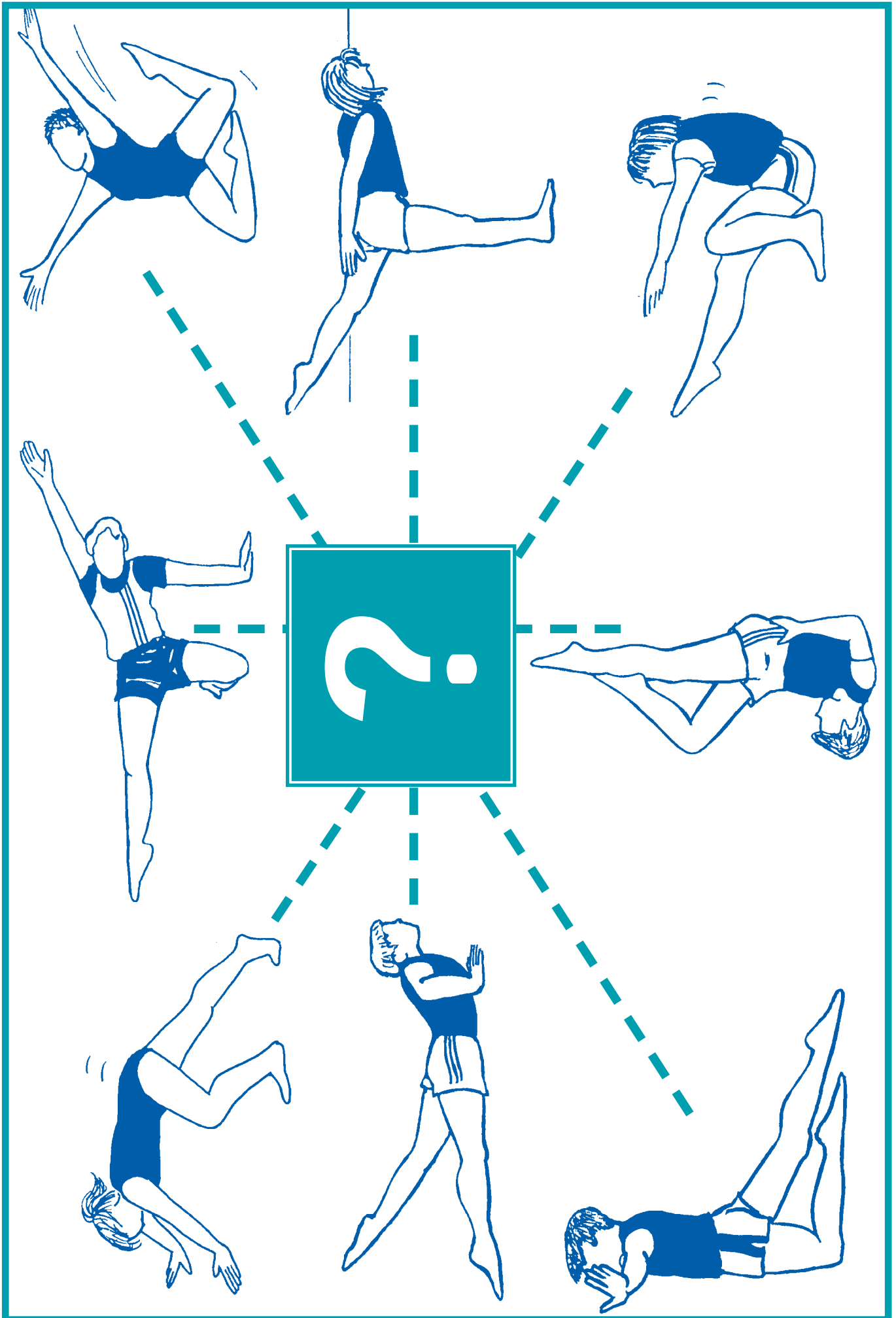



- Cardiovascular Endurance
- Muscular Endurance
- Muscular Strength
- Warm up / Cool down
- Flexibility

# Health Related Activity

*cardiovascular  
endurance flexibility  
muscular strength  
nutrition energy*





# CONTENTS



	<i>Page</i>
<i>Overall Aim and Objectives</i> .....	<b>312</b>
<i>Teacher Guidelines</i> .....	<b>313</b>
<i>Level One</i> .....	<b>315</b>
<i>Learning Outcomes and Content Framework</i> .....	<b>316</b>
<i>Unit Content</i> .....	<b>317</b>
<i>Core Units</i> .....	<b>318</b>
<i>Option A – Integrated Units</i>	
<i>Adventure Activities</i> .....	<b>320</b>
<i>Aquatics</i> .....	<b>321</b>
<i>Athletics</i> .....	<b>322</b>
<i>Dance</i> .....	<b>323</b>
<i>Games</i> .....	<b>324</b>
<i>Gymnastics</i> .....	<b>325</b>
<i>Option B – Focus Units</i> .....	<b>326</b>
<i>Resource Material</i> .....	<b>329</b>

# Overall Aim & Objectives

## **AIMS**

*To provide students with the opportunity to develop an understanding of health related fitness and to apply its principles to participation in physical education activities.*

## **OBJECTIVES**

- To develop an understanding of the role of health related activity in the promotion of well-being.*
- To promote, through participation in relevant activity, an understanding of the scientific principles that underpin health related fitness.*
- To enable students to measure and monitor their physical well-being.*
- To encourage and enable students to take responsibility for their own good health and well-being.*

# Teacher Guidelines

*It is the intention of this programme of study in health related activity [HRA] to provide the students with the knowledge and skills by which they can be enabled to make informed decisions concerning issues of health and personal wellbeing. In addition to acquiring these skills and knowledge, the students should be encouraged to develop a positive disposition towards participation in healthy physical activity.*

## **METHODOLOGY**

The material will require a variety of approaches in order to attain the objectives set out in the programme. The primary focus of the programme in terms of methodology must be to facilitate the use of physical activity as the vehicle whereby the students learn. There will be occasions during which the students will be less active but it must be the intention of the teacher to restrict such occasions to the minimum.

## **EQUIPMENT**

A variety of presentation techniques will require a range of equipment. Each lesson will have a list of relevant equipment. As much as possible the equipment included will be that which is available to most teachers and thus no extra cost should accrue to the school.

## **CONTENT SELECTION**

It is recognised that the health related activity element of the Junior Cycle Physical Education curriculum is delivered most effectively through integration across the programme. Accordingly, the guidelines provided here present the health related activity element as a theme to be explored in a variety of activity contexts.





# Health Related Activity



Level  
One

# Learning Outcomes

The student will:

- *demonstrate an understanding of the effects of exercise on the body*
- *identify the components of health related fitness through involvement in relevant physical activity*
- *show an understanding of the role of physical activity in establishing and maintaining health*
- *develop a capacity to plan for and participate in regular physical activity.*

## Content Framework

At level 1 two options are provided in terms of how one might approach the teaching of HRA.

### Option A:

The first approach taken is to include two core units and six integrated units. The two core units give an introduction to HRA at level 1 and are stand-alone units. The integrated units can be taught following the core units at appropriate times within the year's physical education programme. The examples of integrated units included are adaptations of units from each of the other six activity areas. Teachers may have to plan additional integrated units to suit the activities which they are including in their programme for the year. It is important that integration with the other activity areas is not left to chance and that teachers explicitly plan and deliver units which have a health related focus throughout the year.

<i>Lesson</i>	<i>Activity Area</i>	<i>Concept</i>
<i>Unit 1</i>	<i>Core (stand-alone)</i>	<i>The effects of physical activity on the body</i>
<i>Unit 2</i>	<i>Core (stand-alone)</i>	<i>Components of Health Related Fitness</i>
<i>*</i>	<i>Integrated – Adventure Activities<sup>°</sup></i>	<i>Cardiovascular endurance</i>
<i>*</i>	<i>Integrated – Athletics<sup>°</sup></i>	<i>Warm up, Cool down</i>
<i>*</i>	<i>Integrated – Aquatics<sup>°</sup></i>	<i>Muscular strength and endurance</i>
<i>*</i>	<i>Integrated – Games<sup>°</sup></i>	<i>Cardiovascular endurance</i>
<i>*</i>	<i>Integrated – Dance<sup>°</sup></i>	<i>Flexibility</i>
<i>*</i>	<i>Integrated – Gymnastics<sup>°</sup></i>	<i>Muscular strength and endurance</i>

<sup>°</sup> *As not all of the areas of study will be taught in one school year, teachers will have to adapt other units to ensure all of the above concepts are covered within their physical education programme.*

*\** *The order in which the above are taught will depend on the order in which activities are being taught throughout the year.*

### Option B:

The second approach offered in these guidelines involves the two core stand-alone units, as previously outlined, followed by three focus units to be included within other areas of study at the discretion of the teacher. The concepts explored in the focus units are as follows:

- **Cardiovascular Endurance**
- **Warm up / Cool down**
- **Muscular strength / Endurance**

In making decisions relating to content selection, the teacher should reflect on the following points:

- all activity should be enjoyable and appropriate to the skill level of the students.
- content should derive from the concepts to be taught.
- the themes should be integrated with other aspects of the physical education curriculum so as to fulfil the stated objectives.

In devising the health related activity course, content selected should seek to be relevant to students' lives and to inform life long activity choices

**CORE UNITS**

*Unit 1                    The effects of physical activity on the body*

*Unit 2                    Components of health related fitness*



**OPTION A – INTEGRATED UNITS**

*Adventure Activities    Cardiovascular endurance*

*Aquatics                    Muscular strength and endurance*

*Athletics                    Warm up / Cool down*

*Dance                      Flexibility*

*Games                      Cardiovascular endurance*

*Gymnastics                Muscular endurance*



**OPTION B – FOCUS UNITS**

*Unit 1                    Cardiovascular endurance*

*Unit 2                    Warm up / Cool down*

*Unit 3                    Muscular strength and endurance*



Core unit 1: The effects of physical activity on the body  
**The student will:**

- experience the effects of physical activity on the body
- record perceived changes to the body as a result of physical activity
- demonstrate an understanding of these effects.

**LEARNING OUTCOMES**

**EQUIPMENT**  
 Worksheet (resource materials), music equipment, ribbon per student, balls ratio 1-4

**CLASS ORGANISATION**

STAGE	CONCEPT	CONTENT / ACTIVITY	TEACHING POINTS
Warm up	1. Awareness of <ul style="list-style-type: none"> <li>- temperature</li> <li>- heart rate</li> <li>- breathing</li> </ul> 2. Activity;	Students complete 'pre-exercise' column in work sheet  Pulse raise/ mobilise/prestretch through the following activities e.g. Walking tall, small, various directions. Jogging  Co-operative activity, e.g. The 'get together' game build in stretching. <ul style="list-style-type: none"> <li>• Students travel in various directions</li> <li>• Teacher calls number and students get together in groups of that number.</li> </ul>	Exercise and rest affect heart rate, breathing and body temperature.  The heart muscle acts as a pump to circulate blood throughout the body.  Use music to motivate, if desired.  All students should be involved in continuous, low to moderate intensity activity for an extended period.
Development	Changes due to exercise.  Awareness of body.  Recording and measuring.	All students participate in a range of aerobic activity. Some examples of appropriate activity are provided below. <ol style="list-style-type: none"> <li><b>Ribbon game</b>                              All students have ribbon tucked into back of waistband as "tail". Working in pairs, students attempt to grab partner's tail without losing their own.  <b>Progression:</b> Students attempt to collect as many tails as possible.</li> <li><b>3 v 1 Tag</b>                              Three students with a ball aim to touch a fourth player with the ball in order to get as many points as possible in one minute. When a player receives the ball he/she cannot run or throw the ball at the fourth player. The fourth player tries to avoid the ball by running, dodging, feinting, changing speed and direction.</li> <li><b>Tom n' Jerry</b>                              In groups of 4, one student is Tom, one student is Jerry, the remaining 2 students hold hands to form a barrier. Tom tries to tag Jerry by going around or under the barrier. If Jerry is tagged change roles and repeat.</li> </ol> Interrupt activity and complete "Aerobic" column of worksheet.	Students begin facing each other. Start on signal from teacher.  Use defined area. Caution students as to safety issues.  Ensure that activity has been of sufficient duration and moderate to high intensity. Encourage discussion regarding perceived body changes and their causes - breathing, heart rate, temperature.  Change barrier so that all students get a chance to be Tom and Jerry.
Cool down	Pulse lowering and safe stretching. Complete "post exercise" column of worksheet.		Using recorded results, draw on the students' experience to discuss changes which took place with each of the measures.

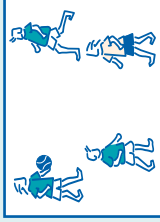



Core unit 2: components of Health Related Fitness

**LEARNING OUTCOMES**

- The student will:
- identify the health benefits of regular activity
  - achieve a basic understanding of the components of health related fitness
  - experience activity relevant to each of the components.

**EQUIPMENT**

Activity diary per student, circuit requirements - balls, skipping ropes, benches, circuit station cards, board, OHP.

**CLASS ORGANISATION**

STAGE	CONCEPT	CONTENT / ACTIVITY	TEACHING POINTS
Introduction	Relationship between activity and health	Use activity diary How can regular exercise benefit you? Brainstorm Q&A	Full Class involvement Focus on the following benefits: <ul style="list-style-type: none"> <li>• increases individual energy level</li> <li>• improves the body's ability to meet the demands and stresses of everyday living</li> <li>• gives a greater sense of well-being</li> <li>• improves self-esteem</li> <li>• reduces risk lifestyle-related diseases by developing a strong heart and muscles, by managing weight and by enhancing joint mobility.</li> </ul>
Development	Components of Health Related Fitness CV Endurance Flexibility Muscular strength Muscular Endurance Body Composition Activity involving each component	Teacher explains components and promotes discussion on health benefits. The ability of the heart and lungs to provide oxygen to the muscles for continuous exercise over a sustained period. The ability to move the joints through a full range of movement without discomfort or pain. The ability of a muscle or muscle group to exert maximum force against a resistance. The ability of a muscle or muscle groups to exert a force repeatedly. The relative percentage of muscle, bone, fat and other tissue which comprises the make-up of the body. <b>Matching Circuit</b> (see resource materials) Circuit preceded by a brief warm up (pulse raiser, mobility and pre stretching). Circuit followed by cool down (pulse lowering and post stretching).	Students complete circuit. At each station students identifies HRF component being developed. On completion, teacher discusses the relationship between HRF components and individual exercises. (Use board or OHP).
Cool down	Physical activity is as necessary for your body as food or sleep.	Distribute activity diary. Activity diary – note health related components worked on.	Discuss plan to keep log for coming week.

Integrated unit 1: Adventure Activities Level 1, Unit 1 – Cardiovascular endurance

**LEARNING OUTCOMES**

**The student will :**

- associate shapes on map with objects on ground
- gain an introduction to CV endurance and how / why it is necessary for orienteering.

**EQUIPMENT**

Borg scale (Resource material), map drawing resources, 9 cones, orienteering route cards, stop watch, symbol recognition cards.

**CLASS ORGANISATION**

STAGE	CONCEPT	CONTENT / ACTIVITY	TEACHING POINTS
Warm up	Map drawing Resting HR	Take resting pulse at wrist i.e., radial pulse (count for 6 secs.). Draw map of hall. Students in pairs identify features on map. Each points to a feature and partner has to run to it and back as quickly as possible.	Explain briefly that resting HR is the number of beats that the heart needs to take, to circulate oxygen when body is at rest.
Development	Relationship between perceived exertion and pulse.  Endurance	Mark 9 cones with symbol / letter. Set out to master plan as in original lesson.  When they return from each attempt, students take HR at carotid pulse – explain why HR is higher (take for 6 secs.) than it was at start of unit. Introduce Rate of Perceived Exertion. R.P.E.: (the rate of perceived exertion) is a method of monitoring intensity. It allows the individual to rate her/his perceived overall effort / exertion in the exercise. Relate level of perceived exertion to heart rate. If student thinks he / she is working 'fairly light' then he/she should have counted 11 beats in 6 secs = HR of 110 beats per minute.  Explain that CV endurance is the ability of the heart and lungs to provide oxygen to the muscles for continuous activity, involving large muscle groups, over a prolonged period of time.	Teacher should have prepared a set of route cards etc. as in original lesson.  Task needs to be set outdoor in a large area.  Students navigate first, run second.  Higher HR due to increased demand for oxygen from muscles. Heart beats faster to bring additional oxygen to muscle groups.  Refer to Borg Scale in resource materials.
Conclusion		Symbol recognition as per original lesson plan if time allows.	

- Integrated Unit 2: Aquatics Level 1, Unit 3 – Muscular Strength and endurance
- The student will :
- gain an understanding of the difference between muscular strength and endurance through participation in
    - feet first / head first entry
    - movement through water on their fronts and backs.

**UNIT OBJECTIVES**

**EQUIPMENT**

Rescue equipment, circuit station cards, equipment as per lesson, music equipment, stop watch, rescus equipment.

**CLASS ORGANISATION**

STAGE	CONCEPT	CONTENT / ACTIVITY	TEACHING POINTS
warm up	Water confidence	Statue Tag: 'Tagged' person must stand or float at point where they were tagged. Released by having others swim between their legs or underneath outstretched arms.	Nominate catchers. Use shallow end. Q. Why is it more difficult to walk / run through shallow water than on land? – A. Your muscles have to continually contract against the resistance of the water, so it places more demands on your muscular strength and endurance.
Development	Entry techniques  Entry: Feet first Head first  Stroke development	L1: crouch jump with/without float straight jump with/without float.  L2: straight & star jump sitting and kneeling dive.  L3: revise jumps dives • sitting • kneeling • crouch • standing.  L1: push & glide with/without float (front) push ball push & glide with/without float (back).  L2: front crawl • back crawl.  L3: as above with breast stroke added.	Buddy in water for assistance.  See resource material for strength. What component of fitness will help you to get greater height or distance on your jump or dive? Muscular strength – the stronger your leg muscles, the stronger your push the higher or further you can jump / dive.  Emphasise streamlining. L1: Push & Glide – you require muscular strength to push off the pool – if you continue to practice this you will require muscular endurance. L2 & L3: You are mostly developing your muscular endurance in your arms and legs as your muscles are continually contracting against the resistance of the water when you push or pull.
Cool down	Cardiovascular endurance Circuit cards  Reach rescue	Circuit: 4 stations • Jogging across pool • walking shoulders under water • star jump • tuck jump • volleyball block • twist • walk  3 Level 1 2 1 Rescue at varying distances from side Shallow end  PRACTICE SETUP	Work interval 45 sec. Rest (and rotation) 15 sec. Use music (electricity precautions). Emphasise: muscular endurance, good posture during exercise.  Rigid objects: poles • buoyancy rings • extended poles with rings • floats – choice of object depends on distance. Non rigid objects: towels • ropes • clothes – choice depends on circumstances. N.B.: Maintain safety of rescuer. No contact with subject. Importance of continuous communication with subject... Keep eye contact. The more streamlined your partner is the less strength required to pull him / her in to land.



Integrated Unit: Athletics – warm up / cool down

In the introduction to the athletics area of study it states that:

**“It is suggested that all classes must start with a warm up and end with a cool down.”**

Specific health related information may be included concerning warm up and cool down in any of the six units but ideally it should be done in unit 1 or 2 or perhaps both in each area of study.

### WARM UP

#### Reasons for warm up:

- gets the heart rate up using vigorous aerobic activity, thus increasing blood supply to the major muscle groups.
- gentle stretching of the major muscle groups warms them up and prepares them for activity.
- reduces the risk of injury.

NB: Differentiate between **warm up stretching** which does not improve flexibility – it merely warms up the muscle and stretches it so that it is ready for the activity to follow, — and **developmental stretching** which is performed to improve flexibility when the body is fully warmed up and stretches are held for much longer e.g. 30 secs. – 1 min.

Students must be shown how to stretch **gently** – never into pain and **never** to use ballistic movements. If desired, the names of the larger muscle groups can be identified when stretching.

### COOL DOWN

#### Reasons for cool down:

- gradual slow down of activity is safer than a sudden severe halt.
- heart rate slows down gradually thus helping to remove lactic acid from muscle groups (no need to go into how this process works at this stage).
- gentle stretching helps tired muscle groups to loosen out and also helps to break up lactic acid.

Typical cool down: jog – walk briskly – walk slowly (2 – 3 mins.) – gentle stretching

Integrated unit 3: Dance Level 1, Unit 2 – Flexibility  
**Body Joints and Travelling**  
 The student will:

- gain an awareness of movement through the joints
- be introduced to movement phases
- identify the range of motion of 2 joints and the muscles acting upon them.

**UNIT OBJECTIVES**

**RESOURCES**  
 Pictures and/or models of the skeleton, poems about the skeleton.  
 Music: 'In dulcilo Jubelito' or '2nd Rendezvous', Jean Michel Jarre.  
 Chart showing muscle groups and joints.

STAGE	CONTENT / ACTIVITY	TEACHING POINTS
warm up	<p><b>Task 1a</b>                      Walk for 8 counts Change direction - 4 times                      Walk for 4 counts Change direction - 4 times                      Walk for 2 counts Change direction - 4 times                      Try this leading with right foot - change leading with left foot</p> <p><b>Task 1b</b>                      Walk for 8 counts, choose a joint, point it to the floor / ceiling / teacher.                      Repeat, using different types of joints.</p>	<p>Being aware of the surfaces of the foot as they make contact with the floor, sensing the skeletal structure softness through the joints.</p> <p>Teacher identifies ball and socket, hinge and pivot joints.</p>
Exploring the idea	<p><b>Task 2a</b>                      Using one joint, find how many ways you can move it, e.g. the shoulder can move forwards / backwards / up / down and around.</p> <p><b>Task 2b</b>                      Experiment with other joints. Find still positions that draw attention to that part of the body, that make it noticed.                      Using chart identify the muscle groups acting on any 2 joints.</p> <p><b>Task 3</b>                      Travel for 8, focus on chosen joint for 8 or move the joint for 8 counts.</p> <p><b>Task 4a:</b> explore different ways of travelling.</p> <p><b>Task 4b:</b> move 2, 3, 4, hold 6, 7, 8. Repeat with knees, elbows and ankles.</p>	<p>Emphasise clarity of placement of joints.                      Emphasise the whole body structure - how it related to a chosen body joint, what is the opposite joint doing?                      Teacher draws attention to wall chart (at least A2 size) and identifies the muscle groups acting on a variety of joints.</p> <p>Emphasise quality of movement</p>
Development	<p><b>Task 5a:</b> select a travelling phrase for 8 counts and a body joint phrase for 8 counts..</p> <p><b>Task 5b:</b> select a starting position, repeat phrases 3 times and select a finishing position.</p>	<p>Change the phrase by using a different body joint, changing the method of travelling, adding one of the body actions (jump, turn, step, gesture, stillness, transference of weight)</p>
Conclusion	<p>Travel to a partner, perform own phrases together and hold.                      Observation: half the class observe, while others perform.</p> <p><b>Suggested Progression:</b> partner work                      Partners (a) copy or mirror each other                      (b) question and answer dance.</p>	<p>Have they travelled clearly?                      Have they shown clarity and focus on their chosen body joint?                      Have they a clear beginning and end?                      Emphasise sensitivity and awareness of each other.</p>
Cool down	<p>Walk into circle.                      Reach a body joint into circle, melt out and walk back out. Repeat x 3.</p>	<p>Emphasise alignment and breathing.</p>

Integrated unit 4: Games Level 1, Unit 4 – Cardiovascular endurance

**LEARNING OUTCOMES**

- The students will:
- display an understanding of the concept of CV Endurance and how / why it is necessary for invasion games
  - experience changes in their heart rate and understand the reasons for these changes
  - understand the problems and concepts inherent in invasion games.

**EQUIPMENT**

Borg scale (resource material), stop watch, equipment as per unit 4, Level 1 Invasion Games.

**CLASS ORGANISATION**

STAGE	CONCEPT	CONTENT / ACTIVITY	TEACHING POINTS
Warm up & stretching	Muscle group identification.	2 v 2 passing games. See how many consecutive passes your group can make. Stretching – identify muscles being stretched.	Check HR before warm up. Check HR after warm up. Give names of major muscle groups.
Development	Monitoring exertion.  CV endurance.  Pulse measurement.	As unit 4 Invasion Games. 4 v 4 Invasion Games. 2 v 2 with agreed rules etc.  If time allows continue with unit as before (in level 1, unit 4 of Games) i.e., 3 v 1. Students play 3 v 1 game with specific boundaries.  If time does not allow for 3 v 1 game, go straight to conclusion.  Rate of perceived exertion. Students rate their own exertion having studied the scale. Relate level of perceived exertion to HR.  Take HR for six seconds.  If student thinks he / she is working 'hard' he should have counted 15 beats in 6 seconds, therefore giving HR of 150 beats per minute.	Use Borg Scale from resource materials. Students take HR immediately upon stopping game.  Explain that CV endurance is the ability of the heart and lungs to provide oxygen to the muscles for continuous activity, involving large muscle groups, over a prolonged period of time.
Conclusion		Gradually decrease intensity of game. Students jog, then walk around court area, while still playing game and focusing on positions etc. Stretching exercise. Check HR at end of cool down. Explain why HR went up during activity then down again at the end of cool down.	Teacher reinforces muscle groups. Teacher explains reasons for decreased HR, i.e., decrease in oxygen debt in muscles due to reduction in level of activity, therefore decrease in demand on heart to provide oxygen to the muscles.

Integrated unit: Gymnastics Level 1, Unit 3 – Muscular strength and endurance  
**The student will:**

- understand the role of muscular strength and endurance when performing balancing weight tasks and travelling
- explain some of the health benefits of muscular strength and endurance.

**EQUIPMENT**

**CLASS ORGANISATION**

**LEARNING OUTCOMES**

STAGE	CONCEPT	CONTENT / ACTIVITY	TEACHING POINTS
Warm up & stretching			<p>Muscular endurance and strength helps you to avoid injury, to tire less quickly, to look better to perform tasks with more ease and to be healthier.</p> <p>Muscle accounts for 40% of your body weight.</p> <p>There are 650 skeletal muscles in our body.</p>
Development			<p>In gymnastics students can enhance their strength by jumping, springing, lifting, hopping, landing, holding moments of stillness, supporting</p> <p>The muscular system allows you to maintain body position and to move body parts.</p> <p>Combining flexibility with muscular strength enables the performer to maintain the full range of movement</p>
Cool down			<p>The demands of everyday life require a low to medium intensity level of muscular endurance.</p> <p>Muscular endurance enables you to hold your body posture.</p>

Focus unit 1 :cardiovascular endurance

**DESCRIPTION** Cardiovascular Endurance is the ability of the heart and lungs to provide oxygen to the muscles for continuous activity, involving large muscle groups, over a prolonged period of time.

**TEACHING SLOT**

Include before, during and after extended period of aerobic activity. Activity chosen should be continuous and involve large muscle groups.

**CONTENT**

Rate of Perceived Exertion. (R.P.E.)

- Students study scale
- Rate their own exertion



aerobic activity

Interpret change in RPE in terms of supply of oxygen to muscles.

**TEACHING POINTS**

**The BORG Scale**

Rating intensity using perceived exertion (RPE)

The RPE scale relates well with heart rate especially in the middle range.

**RPE Scale**

6	
7	Very, very light
8	
9	Very light
10	
11	Fairly light
12	
13	Somewhat hard
14	
15	Hard
16	
17	Very hard
18	
19	Very, very hard
20	

If you have not been involved in regular exercise you should work at the target training zone between 60% – 75% max.

If you have been involved in regular exercise your target training zone should be between 75% – 85% HR max.



Focus unit 2: warm up / cool down

#### DESCRIPTION

**Warm up:** prepares the body for more demanding exercise by increasing the body temperature and the blood flow to the muscles. It prepares the body and mind for exercise and reduces the risk of injury.

**Cool down:** helps the body to recover gradually and to return to a resting state.

TEACHING SLOT  
(10 – 15 mins)

All units. Units with different content will present different warm up and cool down demands. A variety of units may be chosen to explore this focus.

#### CONTENT

##### Warm up

- Gradual preparation.
- Increasing body temp & blood flow.
- Full body movements.
- Mobility actions & safe stretching.
- Specific to impending activity.

##### Warm up stretching

- Warms up muscle and stretches it to prepare for activity.
- reduces the risk of injury.
- Stretch held for 10 - 12 seconds.
- Does not improve flexibility.

##### Cool down

- Gradual recovery.
- Reduce activity through simple movements.
- Keep body moving (esp legs).
- End with stretching.

#### TEACHING POINTS

##### Ensure that:

- all students participate fully.
- pulse raiser is appropriate to the activity to follow.
- warm up lasts 10-15 min.
- stretches held for 10-12 sec.

##### Post-stretch

- Developmental in nature.
- Preferably on floor.
- Stretch held for 15-20 sec.
- Performed towards end of cool down.

Focus unit 3: muscular strength and endurance

**DESCRIPTION**

**Muscular Strength:**

- the ability of a muscle or muscle group to exert against a resistance.

**Muscular Endurance:**

- the ability of the muscles to apply a sub-maximal force repeatedly.

Common muscular endurance exercises are :

- curl ups, chin ups, or repetitions of lifting weights

**TEACHING SLOT**

Any activity which incorporates the use of either components is appropriate. Given the element of overlap arising between these components it may arise that both will present in the same activity.

**CONTENT**

Within activity identify action(s) which represent the application of each component.

Emphasis:

many activities require the use of a combination of muscular strength and endurance.

The context of performance may alter the ratio in which the components are used

Application to everyday life.

Same combination effect arises. Generally one component predominates.

**TEACHING POINTS**

**Examples:**

<b>Mostly Muscular Strength</b>	<b>Mostly Muscular Endurance</b>
---------------------------------	----------------------------------

- |            |              |            |
|------------|--------------|------------|
| Basketball | Javelin Pass | Dribble    |
|            | Set shot     | Chest Pass |

- |          |                 |          |
|----------|-----------------|----------|
| Football | Long Kick       | Passing  |
|          | Shoulder Charge | Catching |

- |           |          |                 |
|-----------|----------|-----------------|
| Athletics | Throwing | Middle Distance |
|           |          | Running         |

Prolonged performance of a "strength" action will require greater application of "endurance".

Pushing a car ... mostly strength

Carrying a schoolbag over a long distance ... mostly endurance

Resource material: Unit 1

Record your heart rate, breathing and body temperature, before, during and after exercise.

HEART RATE	PRE-EXERCISE	AEROBIC	POST-EXERCISE
TAKE FOR 6 SECONDS			
<b>BREATHING</b> Slow, moderate to rapid			
<b>BODY TEMPERATURE</b> Cold, hot, warm			

What was the change in your HR? .....

What changes took place in your breathing and body temperature? .....

What did your muscles need in order to keep exercising? .....

Where did this come from? .....

'Recovery heart rate' is the rate at which your HR returns to resting level.  
The fitter you are the quicker the HR will return to its resting rate, thus reducing the stress on the heart.

Resource material: Core unit 2

DAY	ACTIVITY	HEALTH RELATED FITNESS COMPONENT	TIME SPENT	HOW I FELT e.g. COMFORTABLE, TIRED, EXHAUSTED, RELAXED . . .
MONDAY				
TUESDAY				
WEDNESDAY				
THURSDAY				
FRIDAY				
SATURDAY				
SUNDAY				

Resource material: Core unit 2

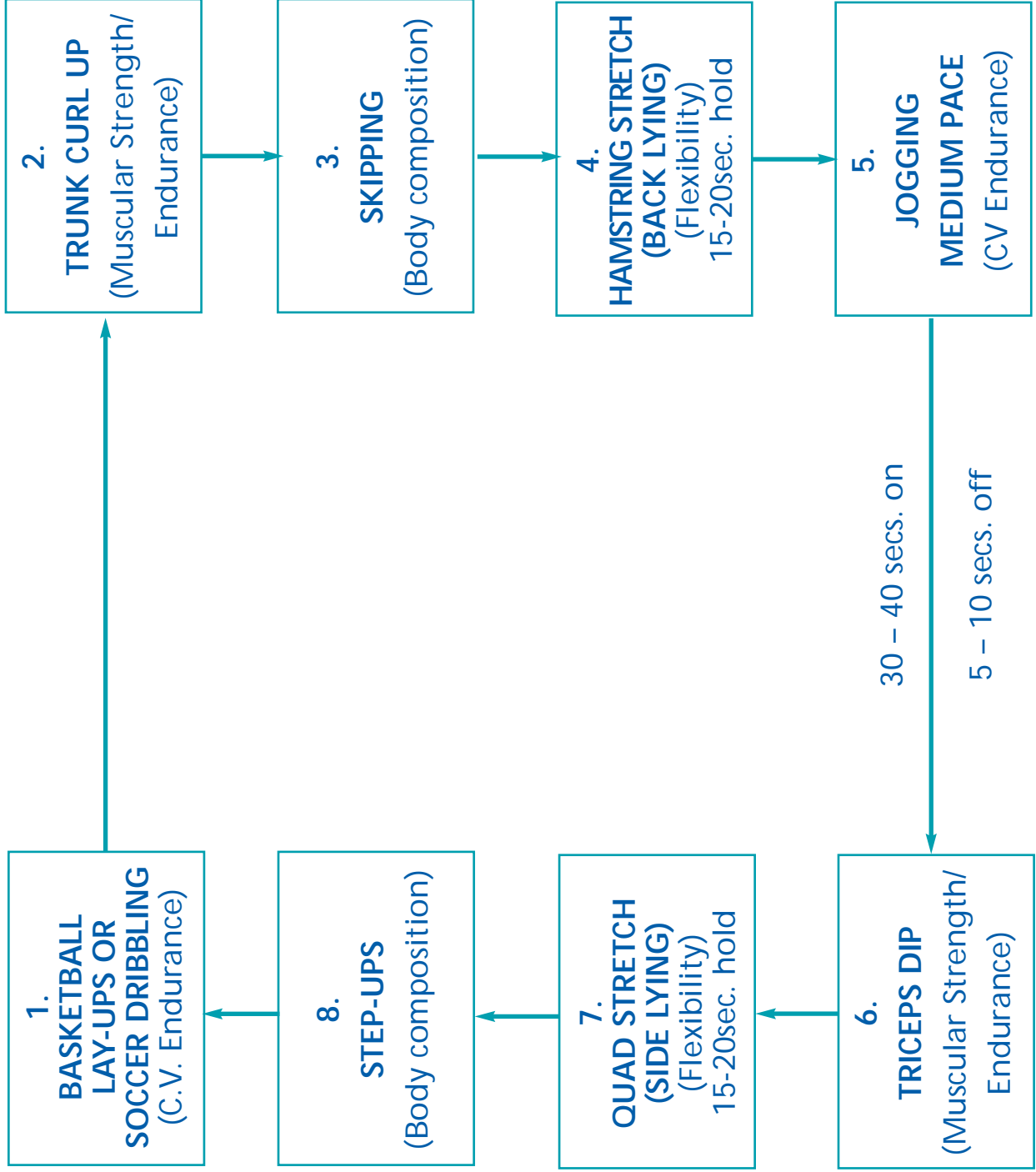

Resource material: gymnastics: muscular strength and endurance

Muscles are working during stillness as well as during moving gymnastic activities.  
 Still: holding a body shape in a balance  
 Moving: travelling, weight transference

**MUSCULAR STRENGTH**

**Definition: the ability of a muscle to exert a force against a resistance.**

When holding a body shape in a balance, tension builds up in the muscles that are supporting you. This is because these muscles are using muscular strength. When travelling using hands, the body weight is supported by the arms, therefore, considerable muscular strength is required.

**MUSCULAR ENDURANCE**

**Definition: the ability of a muscle or muscle groups to repeatedly exert themselves.**

As you hold a balance for a long time you also use muscular endurance in the muscles that have tension.

When travelling using rolls, you require strength in your arms and legs to push you into the roll. To perform a number of rolls in sequence you will also require muscular endurance in your arms and legs.

	<b>Muscular strength</b>	<b>Muscular endurance</b>
<b>Gymnastic activities</b>	Jumping Rolling (pushing with hands and legs) Cartwheels Travelling using hands	All travelling activities, e.g. a number of rolls performed in sequence. Jumping repeatedly
<b>Other physical activities</b>	Pushing a car Throwing a javelin A javelin pass in basketball	Painting a ceiling Playing a game of football Disco dancing for 20 mins.

**Health benefits of muscular strength and endurance**

- Everyday activities such as lifting, carrying, pushing and pulling are easier to perform.
- Good posture is maintained by improving body alignment.

Resource material: Flexibility

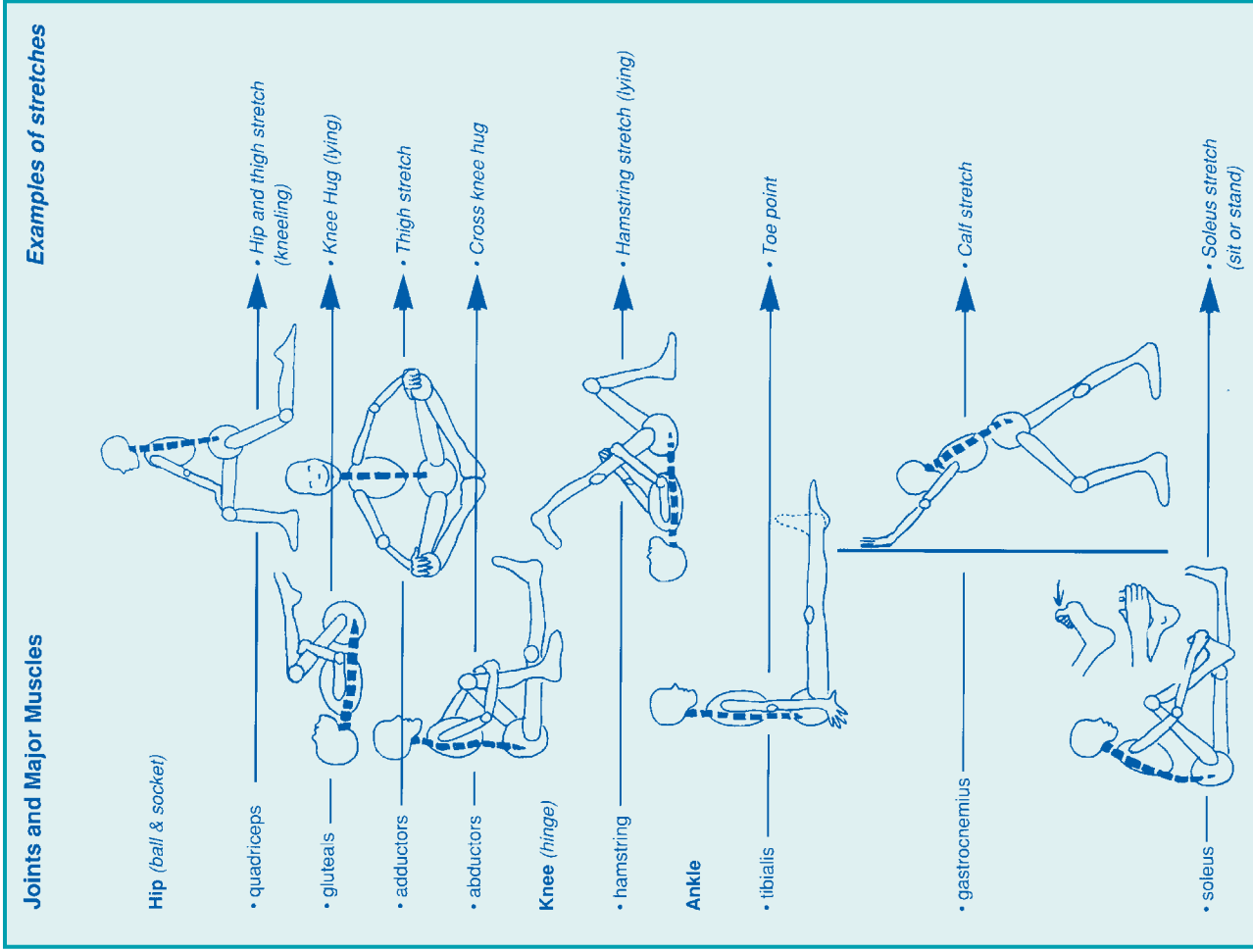
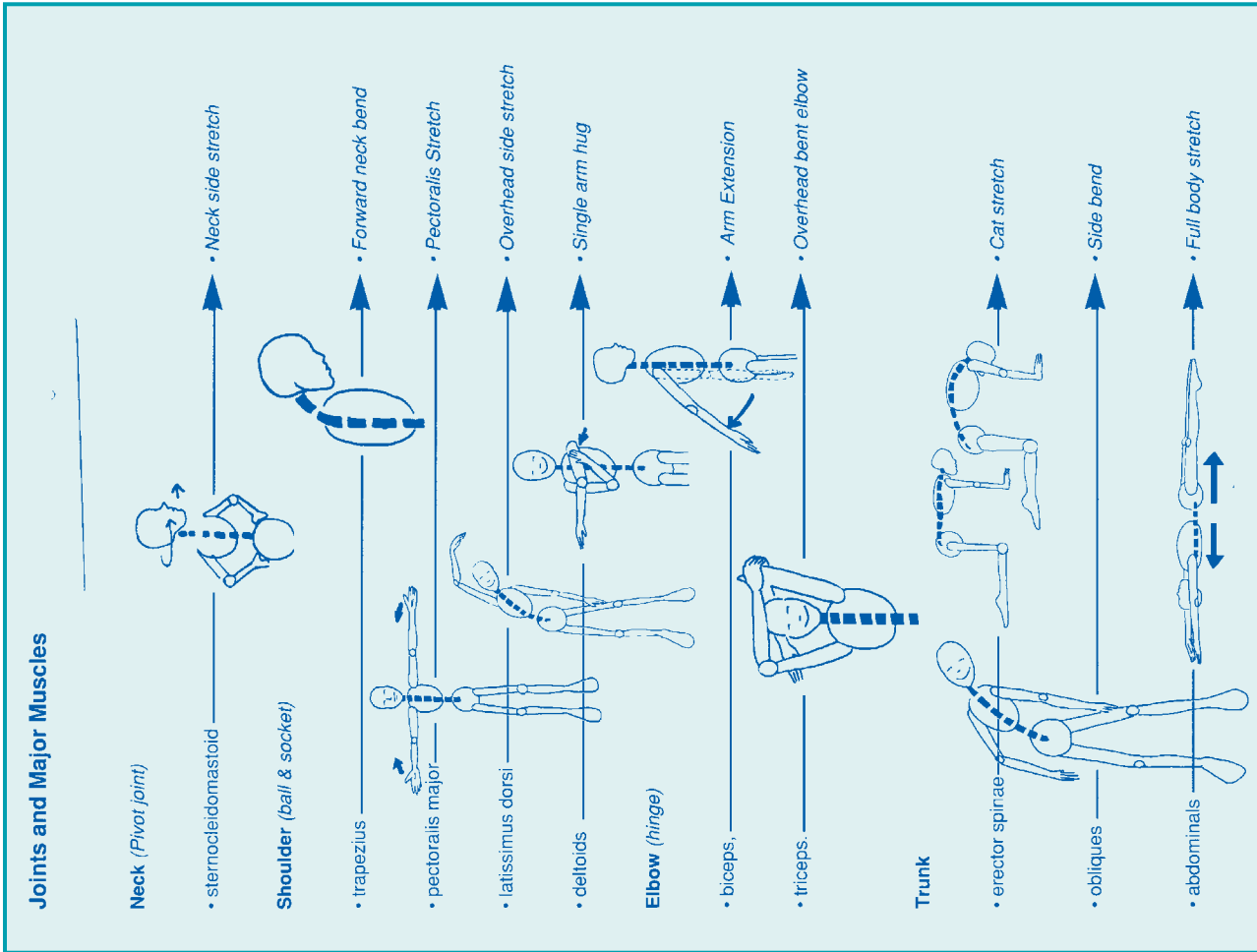

Resource material: Focus unit 3

**MUSCULAR STRENGTH - MUSCULAR ENDURANCE - CARDIO-VASCULAR ENDURANCE**

Each of the activities listed contributes to the development of muscular strength, muscular endurance or cardiovascular endurance. Place a tick in the relevant boxes.

ACTIVITY	MOSTLY MUSCULAR STRENGTH	MOSTLY MUSCULAR ENDURANCE	MOSTLY CARDIO-VASCULAR ENDURANCE
One standing long jump			
Skipping for 15 minutes			
Holding a handstand for 10 seconds			
Throwing a medicine ball once			
Putting the shot once			
Disco dancing for 20 minutes			
Working on a factory assembly line all day			
One soccer free kick			





- Recommended reading

- Acknowledgements

# Resources



*recommended*

*reading*

*acknowledgements*



# RECOMMENDED READING

## ADVENTURE ACTIVITIES

- Balcombe, M. 1995, *Outward bound sailing handbook*, Ward Lock.
- Braggins, A. 1993, *Trail orienteering for disabled people*, Harveys, Perthshire.
- Disley, J. 1971, *Your way with map and compass orienteering*, Blond Educational, Leicester.
- Fleuegelman, A. 1981, *More new games book...and playful ideas from the new games foundation*, Pantheon Books, New York.
- Glover, D.R. & Midura, D.W. 1992, *Team building through physical challenges*, Human Kinetics, Champaign.
- Landgmuir, E. 1984, *Mountaincraft and leadership*, Scottish Sports Council.
- McDougall, I. 1993, *Practise outdoor survival*, Lyons and Burgess.
- McManners, H. 1996, *The outdoor education handbook*, Dorling Kindersley, London.
- McManners, H. 1995, *The backpackers handbook*, Dorling Kindersley, London.
- McNeill, C. Ramsden, J. & Renfrew, T. 1997, *Teaching orienteering*, Harveys, Perthshire.
- McNeill, C. Ramsden, J. & Renfrew, T. 1991, *Start orienteering book 6: games for learning orienteering skills*, Harveys, Perthshire.
- Orlic, T. 1978, *The co-operative sports and games books: challenge without competition*, Pantheon Books, New York.
- Rohnke, K. 1977, *Cowtails and cobras, a guide to ropes courses, initiative games and other adventure activities*, Project Adventure, Kendall/Hunt Publishing, Iowa.
- Rohnke, K. & Butler, S. 1995, *Quicksilver, adventure games, initiative problems, trust activities and a guide to effective leadership*, Project Adventure, Kendall/Hunt Publishing, Iowa.
- Schoel, J. & Maizell, 2002, *Exploring islands of healing: new perspectives on adventure based counselling*, Project Adventure, Hamilton.

## AQUATICS

- Butler, P. 1997, *A guide to becoming a A.S.A. assistant teacher*, A & C Black, London.
- Cregeen, A. & Noble, J. 1988, *Swimming games and activities*, A & C Black, London.
- Eakin, A. 1992, *Swimming: an illustrated guide to teaching early practices*, Eakin.
- Department of Education 1993, *Action for life*, Department of Education, Dublin.
- Guzman, R. J. 1998, *Swimming drills for every stroke*. Human Kinetics, Champaign.
- Sova, R. 1993, *Aquatics activities handbook*, Jones & Bartlett, Boston.

## ATHLETICS

- Carr, G. 1999, *Fundamentals of track and field*, Human Kinetics, Champaign.
- Jacob E. & Fraley, B. 1995, *Complete book of jumps*, Human Kinetics, Champaign.
- Ray S. 2003, *Complete book of throws*, Human Kinetics, Champaign.

## DANCE

- Allen, A & Coley, J. *Dance for all*, David Fulton, London.
- Bedford Interactive Productions Ltd 1999, *Wild child resource pack*, <http://www.dance-interactive.web.com>.
- Cohan, R. 1986, *London contemporary dance school the dance workshop*, Unwin Papers, London.
- Department of Education, Dance Council, Thomond College of Education *Dance in education curriculum project*, Department of Education, Dublin.
- Harlow, M. & Rolfe, L. 1996, *Let's dance*, BBC, London.
- Harlow, M. & Rolfe, L. 1997, *Let's look at dance: building & teaching lessons*, David Fulton, London.
- Lowden, M. 1989, *Dancing to learn*, Falmer Press, London.
- McFee, G. 1994, *The concept of dance in education*, Routledge, London.
- Smith Autard, J. 2002, *The art of dance in education*, A & C Black, London.

## GAMES

- Daly, P. (ed) 1993, *The complete coaching guide to hurling and football*, GAA, Coaching and Games Committee Dublin, Ireland.
- Department of Education, Physical Education Association of Ireland 1997, *Games for understanding: a manual for teachers*, Department of Education, Dublin.
- Griffen, L.L. Mitchell, S.A. & Oslin J.C. 1997, *Teaching sports concepts and skills: a tactical games approach*, Human Kinetics, Champaign.
- Kirk, D. and MacPhail, A., 'Teaching games for understanding and situated learning: rethinking the Bunker-Thorpe model', *Journal of Teaching in Physical Education* vol.21, no.2, Jan.2002, pp 177-191.
- Thorpe, R. Bunker, D. & Almond, L (eds), 1986, *Rethinking games teaching*, Loughborough University of Technology, Loughborough.
- Rink, J., 2002, *Teaching physical education for learning*, McGraw-Hill, Boston.
- Siedentop, D. 1994, *Sport education: quality PE through positive sport experience*. Human Kinetics, Champaign.
- Metzler, M. W. 2000, *Instructional models for physical education*, Allyn and Bacon, Boston.
- Mosston, M. & Ashworth S, 2002, *Teaching physical education*, 5th Edition B. Cummings, San Francisco.

## GYMNASTICS

- BAALPE, 1988, *Gymnastics in the secondary school curriculum*, Whiteline Press, Leeds. Book and Video.
- BAALPE, 1995, *Practice in physical education*.
- Carroll, H.K. and M.E. 1991, *Movement education leading to gymnastics*, Falmer Press, London.
- Department of Education, 1998, *Gymnastics: a manual for teachers*, Department of Education, Dublin.
- Jackman, J. 1992, *Gymnastics: skills and games*, A & C Black, London.
- Underwood, M. (1991) *Agile*, Nelson.
- Williams A. 1997, *Curriculum gymnastics*, Hodder & Stoughton, London.

## HEALTH RELATED ACTIVITIES

Bidde, S. Sallis, J. & Cavill, N. (eds), 1998, *Young and active? Young people and health enhancing physical activity - evidence and implications*, Health Education Authority, London.

Cale, L., Clarke, F., Harris, J., McGeorge, S. & McGeorge, C. 1996, *Keep the beat*, London Heart Foundation, London.

Department of Education, *Action for life - health related fitness programme*, Department of Education, Dublin.

Harris, J. 2002, *Health-related exercise in the national curriculum, key stages 1 to 4*. Human Kinetics, London.

Ratliffe, T. & Ratliffe, L.M. 1994, *Teaching children fitness: becoming a master teacher*, Human Kinetics, Champaign.

## WEBSITES

<http://www.scoilnet.ie/Scoilnet/> Department of Education and Science

<http://www.peai.org>

<http://www.sportsmedia.org>

[http://www.cmc.org/cmc/sfty\\_srv.html](http://www.cmc.org/cmc/sfty_srv.html) (*Adventure Activities*)

<http://www.williams.edu:803/Biology/orienteering/o~index.html> (*Adventure Activities*)

<http://www.ioa.ie> (*Adventure Activities*)

<http://www.athleticsireland.ie> (*Athletics*)

<http://www.olympic.org/index.html> (*Athletics*)

[http://www.olympic.org/uk/utilities/multimedia/gallery/results\\_uk.asp?entid=59&LinkName=Boxing&MediaType=pic](http://www.olympic.org/uk/utilities/multimedia/gallery/results_uk.asp?entid=59&LinkName=Boxing&MediaType=pic) (*Athletics*)

<http://www.csuchico.edu/educ/cguenter/FourArts/DA/DACrmov.html> (*Dance*)

[http://news.bbc.co.uk/sportacademy/hi/sa/golf/video\\_masterclasses/newsid\\_3014000/3014095.stm](http://news.bbc.co.uk/sportacademy/hi/sa/golf/video_masterclasses/newsid_3014000/3014095.stm) (*Games*)

<http://www.pecentral.org/lessonideas/ViewLesson.asp?ID=796> (*Games*)

<http://tennison.com/tennishome.html> (*Games*)

[http://www.rugby.com.au/verve/resources/PE\\_secondary\\_Lesson\\_1.pdf](http://www.rugby.com.au/verve/resources/PE_secondary_Lesson_1.pdf) (*Games*)

<http://www.gaa.ie/> (*Games*)

<http://www.eteamz.com/volleyball/instruction/tips/tip.cfm/1847/> (*Games*)

[http://www.education-world.com/a\\_tsl/archives/99-1/lesson0009.shtml](http://www.education-world.com/a_tsl/archives/99-1/lesson0009.shtml) (*Health Related Activity*)

<http://vilenski.org/science/humanbody/project/rotationd/index.html> (*Health Related Activity*)

**National Certificate in Exercise and Fitness:** [www.ncefinfo.com](http://www.ncefinfo.com)

**Wired for health:** [www.wiredforhealth.gov.uk](http://www.wiredforhealth.gov.uk)

**Physical activity website for teenagers:** [www.NRgize.co.uk](http://www.NRgize.co.uk)

**National Disability Authority:** [www.nda.ie](http://www.nda.ie)

**English feberation of Disability Sport:** [www.efds.co.uk](http://www.efds.co.uk)

## PHOTOGRAPHIC ACKNOWLEDGEMENTS

Permission to use diagrams and pictures has been sought where possible. The Department of Education and Science is grateful to all authors for permission to use photographic and diagrammatic materials.

